

**Conference
Proceedings**

2024



MICER

MALAYSIA INTERNATIONAL CONVENTION
ON EDUCATION RESEARCH & MANAGEMENT

**Education Towards
a Global Citizen
Generation**

e ISBN 978-967-2072-45-4



9 789672 072454

4-5 May 2024

*The Straits Hotel and Suites,
Melaka, Malaysia*

Hybrid Conference

ORGANISER :



WMIT Group Sdn Bhd

SUPPORTED BY :



Meet in 
Malaysia
BE Greater, Together.





Proceedings

The 3rd Malaysia International Convention on Education Research Management 2024 (MICER2024)

“Education towards a Global Citizen Generation”

4-5 May, 2024
The Straits Hotel and Suites, Melaka
Physical & Online Conference

All rights reserved. No part of this publication may be reproduced, stored in a retrieval system, or transmitted in any form or any means, electronic, mechanical, photocopying, recording or otherwise, without prior permission, in writing, from the publisher.

The views and opinions expressed therein are those of the individual authors and any statements in this publication do not imply endorsement by the publisher or the editorial staff.

eISBN 978-967-2072-45-4

e ISBN 978-967-2072-45-4





**Proceedings
The 3rd Malaysia International Convention on Education Research
Management 2024 (MICER2024)**

eISBN 978-967-2072-45-4

Table of Contents

No.	Paper ID No.	Title	Page No.
1.	043-021	Sustaining International Education With Metaverse-Based Learning For Chinese: A Systematic Review (2019–2023)	4
2.	053-029	Research On Entrepreneurship Education Methods In The Form Of Digital Modules	18
3.	055-031	Empowering Global Citizens Through Sustainable Fashion Curriculum: A Paradigm Shift In Pedagogy And Practice	47
4.	057-032	Exploring Pedagogy Components Used By The Lecturer To Teach Quantity Surveying Measurement Courses: A Pilot Study	63
5.	063-037	Aplikasi <i>Augmented Reality</i> (Ar) Bagi Topik Bentuk Geometri 3d Dalam Kalangan Pelajar Tingkatan 2	78
6.	077-054	To Improving The Knowledge Mastery About Principles Of Education Of Undergraduate Students In The Education Course Through The Implementation Of Obe	91
7.	090-056	History Teaching And Multi-Disciplinary Integration:An Analysis Among Junior High School Students In China	105
8.	093-062	Confirmatory Factor Analysis Of Continuous Professional Development Constructs Among Islamic Education Teacher	118
9.	096-064	Study On The Comprehensive Promotion Effect Of Fun Track And Field On Children's Physical Quality	134
10.	091-067	Analysis Of Curriculum Needs Based On Local Problems (Sadong Jaya District)	144
11.	004-076	Needs Analysis For Development Of Science Laboratory Educational Comic On Improving Science Laboratory Safety Awareness Among Secondary School Students	145
12.	095-099	The Influence Of L2 Motivational Self System On The Willingness To Communicate Among Chinese Undergraduate Students In English Medium Instruction Classrooms	146
13.	125-103	The Views Of Primary School Teachers Towards Math Syllabus For Upper Standards	157
14.	128-105	Organizational Culture On Employee Performance: A Case Study On Civil Servants In Palembang Indonesia	165



No.	Paper ID No.	Title	Page No.
15.	129-106	Kesesuaian Teori Kepimpinan Distributif Dengan Komitmen Dan Kepuasan Kerja Dalam Menangani Isu Sumber Di Organisasi Pendidikan	173
16.	074-110	Double Reduction Policy: The Preferences, The Challenges, And Recommendations Base On Headmaster, Teachers, Parents And Children Perspective In Xin Jiang	185
17.	133-111	Sintesis Kepimpinan Transformasional Untuk Meningkatkan Efikasi Kendiri Dan Kepuasan Kerja Guru Di Organisasi Pendidikan	196
18.	131-125	Enhancing Physical Education Through Hybrid Pedagogical Models: A Comprehensive Analysis	210
19.	156-136	Digital Renaissance: Reinventing Tertiary Language Teaching And Learning Strategies In Evolving Digital Landscape	219
20.	116-102	Advanced Software-Based Teaching And Learning For Architectural Studio Module	249
21.	059-035	Ketagihan Internet Dalam Kalangan Murid Sekolah Rendah Di Kuala Lumpur Dan Kesannya Terhadap Pencapaian Akademik	261



043-021

SUSTAINING INTERNATIONAL EDUCATION WITH METAVERSE-BASED LEARNING FOR CHINESE: A SYSTEMATIC REVIEW (2019–2023)

XIE XIAONING (p130383@siswa.ukm.edu.my)

ABSTRACT

Metaverse technology is highly immersive and intelligent, which can be perfectly integrated into international Chinese education, promote the innovation and development of traditional international Chinese education, improve the efficiency of foreign students in learning Chinese characters, and better help foreign students to improve their Chinese language ability and proficiency. Therefore, this review systematically identifies trends in m-learning related to International Chinese Education using 4 databases, namely Web of Science (Wos), Scopus, Science Direct and Taylor & Francis e-Journals (PPV). A total of 13 articles were identified through a systematic search of "Chinese learning" OR "Chinese education" OR "Chinese courses" AND "metaverse" OR "metaverse-Based Learning" OR "techniques" OR "International Chinese Education". 13 articles were extracted from the 332 articles available between 2019 and 2023, taking into account the exclusion and inclusion criteria. First, important findings indicate the ways in which metaverse technologies are used in international Chinese education, which are grouped into six categories in this review. Second, the difficulties in international Chinese education are mainly related to pinyin, strokes of Chinese characters and the lack of Chinese learning environment. Overall, this review is valuable for practitioners to understand the ways in which metaverse technology can be applied in international Chinese education and to identify the points of difficulty in international Chinese education so that international Chinese education can be sustainable in the future.

Keywords: International Chinese Education, Metaverse, Higher Learning, Techniques.

1. Introduction

International Chinese language education has significant cross-national, cross-cultural, and cross-time and space characteristics. Compared with other disciplines and majors, its talent training goals also have more prominent integration of knowledge, skills, and literacy. However, its teaching process lacks obvious characteristics. Both interactivity, immersion and practicality restrict the development of international Chinese education. Its personnel training objectives also emphasize knowledge, skills, and literacy integration, but its teaching methodology lacks the clear interactive, immersive, and practical constraints that would otherwise limit the field's growth. The incorporation of the metaverse into international Chinese education thus have many benefit: the metaverse can effectively spur innovation and transformation of the Chinese learning experience, mode, environment, etc. because of its immersive and real sense, interactivity and sociality, freedom and openness, etc.;

This study aims to evaluate the literature in order to systematically identify metaverse strategies that can be used in Chinese education abroad. The following general questions guided the analysis of the following literature:



Question 1: How can Metaverse technology be used in international Chinese language education?

Question 2: What are the difficulties in international Chinese language teaching?

By addressing these issues, this study hopes to support the evolution of teaching strategies and methods as well as offer insights and recommendations for international Chinese education organizations on how to integrate metaverse technology into international Chinese education.

1.1 Development trend of Chinese international education based on metaverse

Meta-universe technology includes advanced extended reality technology, digital twin technology, artificial intelligence technology and advanced equipment, and has functions and advantages that traditional online virtual worlds do not have, such as a high degree of immersion, sharing and co-creativity, integration of the real and the imaginary and entertainment, etc[21]., which can break the boundaries between the real and virtual worlds, and empower the innovation and development of education and teaching both online and offline[22]. Relying on the advanced technology of the metaverse to build an educational metaverse can develop and change the traditional ways and means of education and teaching, and create a freer virtual world for learning. [18]Therefore, in international Chinese language education, making full use of the digital twin and augmented reality technologies of the metaverse, reconstructing or reproducing real virtual scenes in teaching, breaking the time and space limitations, and helping students to create all kinds of free and interesting teaching scenes, both online and offline[23], to meet the needs of teaching and to give full play to the features and advantages of the metaverse, such as its high degree of immersiveness, fun and intelligence, in order to better complete the teaching and learning work[24]. advantages of the meta-universe to better complete the teaching work.[25]

2. Methods

This systematic review follows the preferred reporting project approach for Systematic Review and Meta-Analysis (PRISMA), As shown in Figure 1.

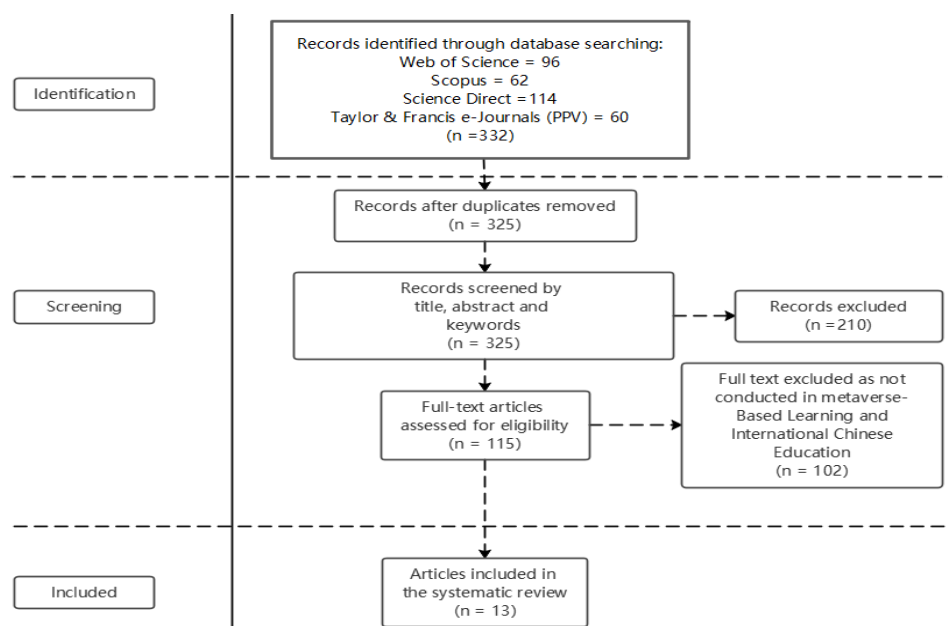

Figure 1. PRISMA systematic review adapted from [14]



2.1 Identification

The first step is to select four suitable databases (Web of Science (WoS), Scopus, Science Direct, and Taylor & Francis e-Journals (PPV).) Table 1 below shows the search strings used for each database in this study.

Table 1. search string

Database	KeywordUsed
Scopus	TITLE-ABS-KEY(("Chinese learning" OR "Chinese education" OR "Chinese courses" AND "metaverse" OR "metaverse-Based Learning" OR "techniques"OR "International Chinese Education"))
WebofScience	TS =(“Chinese learning” OR “Chinese education” OR “Chinese courses” AND “metaverse” OR “metaverse-Based Learning” OR “techniques”OR “International Chinese Education”)
ScienceDirect	metaverse-Based Learning AND Chinese learning AND International Chinese Education AND techniques
Taylor & Francis e-Journals (PPV)	metaverse-Based Learning AND Chinese learning AND International Chinese Education AND techniques

*: Search String

2.2 Screening

The search results of the selected databases showed that before 2019, relevant articles were very sparse and not clearly oriented. Since 2019, the number of articles on Chinese international education research based on Yuan University has increased exponentially. However, there are not many systematic reviews after 2019. Therefore, 2019 to 2023 was used as one of the inclusion criteria. To ensure the quality of the research, only studies with empirical data published in journals were included in the review. In addition, only articles written in English were included to minimise misinterpretation, as shown in Table 2.

Table 2. Screening condition

Criterion	Eligibility	Exclusion
Timeline	Between 2019 to 2023	<2019
Literature type	Articles from journals	Systematic reviews, books, chapters in a



book, conference proceedings

Language	English	Non-English
Scope	Related to metaverse-Based Learning and International Chinese Education	Not related to metaverse-Based Learning and International Chinese Education

After careful screening according to inclusion and exclusion criteria, 13 articles are likely to be included in this systematic review. Although the proceedings and book chapters were reviewed, they were excluded as not comprehensive enough [15]

2.3 Included

The articles for this systematic review revolved around "Sustaining International Education with Metaverse-Based Learning for Chinese". as shown in Table 3.

Based on the table above, 8 articles were chosen from Scopus , 3 from WoS, 1 from Science Direct and 1 from Taylor & Francis e-Journals (PPV).

The aims of these studies are related to international education based on the metaverse. Most of the studies have been conducted at the higher education level, including universities and colleges [1-13]. Most of the studies have focused more on teaching Chinese characters using the intelligent features of metaverse technology [2, 3, 5, 7, 8, 10, 11, 13] and conducting intelligent tests and evaluations [1, 2, 3, 6, 7, 8, 11, 12].

Table 3. Summary

Study	Database	Aim	Samples	Findings
Dai, Q. (2023)	Scopus	This paper probes into the development, characteristics, advantages, disadvantages and problems of Chinese international education and teaching under the new media environment.	International school students	This study improves the correlation by improving the algorithm and provides a useful reference for international Chinese teaching.
Fan, J. (2023)	Scopus, WoS	A model of future intelligent teaching environment based on meta-universe is proposed.	Students in the Faculty of International Education	The model combined with the meta-environment is constructed to solve the problems of poor interactivity and lack of social and cultural context in overseas Chinese teaching
Nie, Y. (2023)	Scopus, WoS	This paper discusses how to understand the theory of multimodal	Two classes of 2021 at a secondary	In addition to the basic advantages of the research model, such as efficiency,



		discourse analysis by teaching Chinese as a foreign language	school in Qingdao, China	speed, flexibility and specificity, the research model significantly improves students' overall academic performance, especially in listening, speaking and reading.
Zhang, Q. (2022)	Scopus	Combining virtual reality technology, we are exploring the role that immersive VR technology can play in international Chinese language teaching scenarios.	Supplementary survey: 200 questionnaires were distributed	The results show that the remote international Chinese teaching model based on the situational cognition theory has a positive impact on students' Chinese learning.
Shen, L., & Latif, F. (2022)	Scopus	The effectiveness of an expert system for international Chinese Language education based on artificial intelligence and machine learning algorithms.	University School of International Education Chinese Class: 11 Chinese language learners from 8 different countries	An expert system for international Chinese education based on artificial intelligence and machine learning algorithm is constructed, which can improve the effectiveness of international Chinese education teaching and has good results and data availability
Zhao, J. (2022)	Scopus	Construction of mobile environment for language learning in Chinese universities based on intelligent reinforcement learning (RLT) in wireless network environment.	Undergraduate students enrolled in Chinese universities	The results show that the accuracy rate of reinforcement learning is 98.78%, which improves the learning efficiency of the subjects.
Zhang, X. (2023)	Scopus	Research on the improvement path of international Chinese education management in colleges and universities based on big data technology	Faculty and students at the Institute of International Education	The results show that online education system can meet students' individual learning needs and improve learning results.
Zhang, X.	Scopus	the constructed	Teachers	It can diversify to meet the



(2023)		Chinese international education platform was analysed in terms of multiplicity and interactivity indicators.	and Chinese learners of the four levels of ABCD in the Chinese Language International Education Platform (CLEP)	Chinese learning needs of different groups of people and improve the teaching level of Chinese language education.
Shen, S. Y. (2023)	WoS	Exploring how developments in meta-universe and virtual reality (VR) technologies can improve Chinese language outreach	APP users	By optimising the algorithm, it allows traditional culture to break through the limitations of time and space.
Yuan, J., Liu, Y. Q., Han, X. C., Li, A. P., & Zhao, L. (2023)	WoS	This study aims to verify the effectiveness of VR tools in stimulating adult learners' English learning and expression through the practice of a pilot reform project.	VR practical pilot class (67 students) and control class (67 students)	the real experience in the virtual world can enhance the teaching and learning effect in the university classroom.
Shu, X. Y., & Gu, X. Q. (2023)	WoS	Explore how an intelligent education model supported by the Edu-Metaverse can improve student learning outcomes	60 students from Zhejiang Broadcasting University	The Edu-Metaverse empowered intelligent education model features highly immersive experiences, multimodal interactions, and highly free resource sharing and creation.
Southworth, J., Migliaccio, K., Glover, J., Glover, J., Reed, D., McCarty, C., Brendemuhl, J., & Thomas,	Science Direct	Integrate AI into traditional research university curricula.	6,000 students at the University of Florida.	The model is innovative in its 'cross-curricular AI' design, incorporating different learning methods and styles.



A.
(2023)

Harrison, T. (n.d.). (2023)	Taylor & Francis e-Journals (PPV)	Leading EdTech developer and providing theoretical, conceptual and practical insights to help ensure the promise of vr enhanced character education is realized	University students	VR can provide character educators with four types of learning opportunities that are not possible in the traditional classroom.
-----------------------------	-----------------------------------	---	---------------------	--

2.4 Data Analysis Procedure

All selected articles are exported to the reference software Mendeley. matic analysis was performed to identify the main themes to answer the following questions research questions:

Question 1: How can Metaverse technology be used in international Chinese language education?

Question 2: What are the difficulties in international Chinese language teaching?

This review provides an interpretive analysis of the articles and categorises the themes in response to the research questions.

According to the first research question, the ways in which meta-universe techniques are used in international Chinese education were classified into six categories. For the second research question, an explanation is given based on the characteristics of Chinese language mentioned in the article, which is divided into three parts of the reasons: the pinyin of Chinese characters, the strokes of Chinese characters and the lack of environment for learning Chinese language, and the difficulties of Chinese language international education are analysed based on these two parts.

3. Results

3.1.1 Question 1: How can Metaverse technology be used in international Chinese language education?

In this systematic review, there are six ways to apply metaverse technology in international Chinese education

1. Teaching Chinese characters using the intelligent features of metaverse technology
2. Learning Chinese characters using the immersive features of metaverse technology
3. Developing Chinese character games using metaverse technology
4. Using the social features of the metaverse
5. Using metaverse to enhance the cultural and interesting aspects of teaching Chinese characters
6. Using the metaverse for intelligent testing and evaluation



Table 4. The application of metaverse technology in the international approach to Chinese education

Type	Related articles
Teaching Chinese characters using the intelligent features of metaverse technology	[2,3,5,7,8,10,11,13]
Learning Chinese characters using the immersive features of metaverse technology	[4,8,9,10,13]
Developing Chinese character games using metaverse technology	[8,10]
Using the social features of the metaverse	[2,9]
Using metaverse to enhance the cultural and interesting aspects of teaching Chinese characters	[8,10,13]
Using the metaverse for intelligent testing and evaluation	[1,2,3,6,7,8,11,12]

As shown in Table 4, this review divides the ways in which metacosmic technologies are used in international Chinese language education into six categories.

First of all, most of the literature [\[2,3,5,7,8,10,11,13\]](#) collectively show that intelligent technology is an important support of meta-universe technology, so it is necessary to closely integrate artificial intelligence in meta-universe technology with Chinese character teaching. By combining international Chinese language teaching with meta-universe artificial intelligence, making full use of the advantages of meta-universe technology, further reflecting the three-dimensional and three-dimensional characteristics of Chinese characters, and enhancing the teaching effect through multi-sensory stimulation, we can improve foreign students' understanding of Chinese characters and visual input, enhance the intuitive and interesting teaching of Chinese characters, and improve the efficiency of Chinese character learning for students.

Second, some of the literature [\[4,8,9,10,13\]](#) mentioned the immersive features of metaverse technology as a way to learn Chinese characters, and these five articles focus more on the combination of VR or visualisation tools to integrate the virtual world with the real world in many ways and provide people with an immersive experience. For teaching Chinese characters to foreign students, metaverse technology can fully play its immersive features by creating a virtual world of Chinese characters through metaverse, which highly reproduces the environment in which Chinese characters are used in various real-life scenarios, such as near real life and work. Foreign students can incarnate themselves as the masters of the virtual world of metaverse with the most direct first-person perspective, immerse themselves in all kinds of things with Chinese labels, and communicate freely with all kinds of purely Chinese-expressive people around them, so that learners are immersed in the Chinese language experience, which can help learners to integrate into the target language environment faster, cultivate the formation of Chinese-expressive thinking, and improve the immediacy and effectiveness of Chinese language learning. Under the teacher's guidance, foreign students can enter a variety of corresponding virtual Chinese worlds, consciously or unconsciously come into contact with



scenarios with similar or even higher levels of Chinese proficiency, and participate in them to complete corresponding tasks or communicative activities. In this kind of immersive meta-universe world, from Chinese characters to vocabulary to paragraph expressions, point by point, foreign students can further deepen their mastery of the basic knowledge of Chinese characters and further use them, and gradually get familiar with the thinking of Chinese expressions, so that their Chinese characters and Chinese language skills will surely develop and improve rapidly.

Third, the use of meta-universe technology to develop Chinese character games in international Chinese language teaching, which is reflected in the literature [8,10], using meta-universe technology can develop games related to the function of Chinese character usage, and design a variety of Chinese character games with a strong sense of participation. In the process of playing various word games, students can not only consolidate the basic knowledge of Chinese character writing and pronunciation, but also further master the function and use of Chinese characters in vocabulary and sentences.

Fourth. Using the social function of metaverse in international Chinese language teaching, which is reflected in the literature [2,9], metaverse has strong social and game functions, which will bring people a panoramic social perceptual experience, create the presence effect of the virtual and real scenes together, and especially provide people with real social and emotional experiences. The metaverse can provide people with social forms such as games, entertainment, work, life, etc., and provide people with a very realistic social perception experience. Metaverse has a powerful social function, and Chinese is an important tool for people to transmit information and an important means for people to achieve social functions. Therefore, international Chinese teachers can give full play to the social function of the meta-universe so that foreign students can use Chinese as a medium in the process of social activities or behavioural implementation. To guide foreign students to use Chinese in learning and learning by using Chinese.

Fifth. In the literature [8,10,13], the use of meta-universe to improve the cultural and interesting aspects of teaching Chinese characters was mentioned in common, where it was pointed out that the meta-universe technology can reproduce many historical stories related to Chinese characters through its digital regeneration technology, which can enable foreign students to learn Chinese characters and understand the stories behind the Chinese characters at the same time.

Sixth. Many literatures [2,3,5,7,8,10,11,13] collectively show the teaching method of using meta-universe for intelligent testing and evaluation, and most of these eight literatures are biased towards algorithmic research, involving meta-universe technology big data, artificial intelligence, blockchain and other technologies in their articles. For example, literature [10] collects data such as foreign students' problems and difficulties in the process of learning Chinese characters through big data, records students' long-term, real and accurate learning process, learning results and various related data, and then conducts intelligent evaluation, analysis and diagnosis through artificial intelligence technology to form a relatively complete and accurate visual analysis report, so as to make a multi-faceted and diversified evaluation in a timely manner. In [8], after analysing and discovering the problems of foreign students' Chinese characters learning through meta-universe technology, based on the results and evaluations of intelligent test, the teacher can have a clearer understanding of the foreign students' strengths and weaknesses in phonetics, morphology and meaning of Chinese characters, and then make full use of artificial intelligence, virtual reality and other



technologies to give the corresponding learning plans or suggestions to help the students to check the shortcomings and make up for the shortcomings.

3.1 Question 2: What are the difficulties in international Chinese language teaching?
 This systematic review concludes that the difficulties in Chinese language international education are mainly in the following three areas

- 3. Lack of Chinese learning environment
 - 1. Pinyin of Chinese Characters
 - 2. Strokes in Chinese Characters

Table 5. Difficulties in international Chinese language education

Type	Related articles
Lack of Chinese learning environment	[1,2,3,4,5,6,7,8,9,10,11,12,13]
Pinyin of Chinese Characters	[2,3,5,7,8,10,11,13]
Strokes in Chinese Characters	[2,3,5,7,8,10,11,13]

First of all, in most of the literature [\[1-13\]](#) dealing with international Chinese education based on the meta-universe, when it comes to the difficulties of Chinese education, they all focus on this problem, that is, the lack of Chinese learning environment, which is an unavoidable problem for international Chinese education. Foreign students from non-Chinese cultural circle countries, such as Africa, South America, etc., whose countries or regions lack the Chinese language background, naturally lack the Chinese character environment. Therefore, the chances of using and reproducing Chinese characters are very small, and can only be concentrated in a few classrooms, exams and homework, and the chances of using Chinese characters are very small, and only a few foreign students will spend a lot of time practising and using Chinese characters after class. Few foreign students will spend a lot of time practising and using Chinese characters after class. Nowadays, the addition of metacosmic technology is hoped to better solve this problem.

The second difficulty relates to the pinyin of Chinese characters, which has been mentioned in the literature [\[2,3,5,7,8,10,11,13\]](#) in the context of Chinese education, and which is one of the most important modules of Chinese language learning. Chinese characters are planar scripts of an ideographic nature, in which glyphs and syllables correspond to each other, and are morphemic scripts for recording morphemes; whereas the pinyin scripts used by most peoples in the world are epigraphic scripts, which mainly consist of a series of linearly arranged letters. Mr Liu Xun pointed out that Chinese characters are morphemic characters that record morphemes, and alphabetic pinyin characters that record phonemes are fundamentally different writing systems, and the difference between the two is enormous [\[2\]](#).

The third point of difficulty concerns the strokes of Chinese characters, Chinese characters have a large number of strokes and components and a complex morphological structure, and although they have a certain rationale, they are not very regular as they continue to evolve and simplify [\[2,3,5,7,8,10,11,13\]](#). Even Chinese students struggle when they start to learn Chinese characters. It is even more difficult for foreign students, especially those from non-Chinese writing cultures, to learn Chinese characters because their native scripts are different in nature from Chinese characters, and their cognitive approaches to phonetics, morphology and meaning are very different. In international Chinese language education, the difficulty of teaching and learning Chinese characters is also a widely recognised issue.



4. Discussion

The results of the study highlight the ways in which metaverse technology can be applied in international Chinese education. The ways of application include:

1. Teaching Chinese characters using the intelligent features of metaverse technology
2. Learning Chinese characters using the immersive features of metaverse technology
3. Teaching Chinese characters using the intelligent features of metaverse technology
2. Learning Chinese characters using the immersive features of metaverse technology
3. Developing Chinese character games using metaverse technology
4. Using metaverse to enhance the cultural and interesting aspects of teaching Chinese characters
6. Using the metaverse for intelligent testing and evaluation
- Using the metaverse to enhance the cultural and interesting aspects of teaching Chinese characters
- 6.

The above approaches are likely to be used on a larger scale in international Chinese language education in the future, linking metaverse technology and international Chinese language teaching more closely. The use of metaverse technology focuses more on combining learners' own interests and abilities, helping learners to understand their own learning progress and experience Chinese learning in depth, so as to achieve the role of facilitating learning, for example, the VR, artificial intelligence and big data apps listed in the article [1-13], which help learners to learn more conveniently from various aspects.

Next, this review also discusses the difficulties in international Chinese education, the reasons for which are summarised in three points, including:

1. Lack of Chinese learning environment [1-13]
2. Pinyin of Chinese Characters
3. Strokes in Chinese Characters.

The first reason is that most of the international Chinese learners will face the problem, in addition, the Chinese pinyin and strokes are also the key point and difficult point of Chinese learning. Nowadays, the addition of Metaverse technology is to solve this problem better, and the use of Metaverse technology as a tool or an aid in international Chinese language education will have a positive impact on Chinese learners.

Finally, this review discusses the important significance of metaverse technology to the update and reform of Chinese character teaching methods in the international community. It can provide new ideas, methods and means for future Chinese character teaching, and has very broad application prospects.

One limitation of this review is that Metaverse technology is still in its infancy, the maturity and popularity of technology and equipment are limited, and the application of various technologies in education and teaching needs to be further strengthened; the application of Metaverse technology in actual teaching has a significant impact on investment, technology, equipment and teachers are relatively high, which is a heavy burden for each school or teaching point. In addition, Chinese international education involves many countries and regions. Due to the huge differences in economic and technological conditions between countries or regions, it is difficult for international students in many economically backward countries and regions to have the equipment and conditions to use Metaverse technology. These are Metaverse technology. The main challenges and difficulties in the practical application of space technology require continuous practice and exploration. The application of metadata technology in Chinese character teaching in international Chinese education still has a long way to go.



5. Conclusions

In summary, this systematic review related to international Chinese education based on the metaverse. Therefore, the gap of no systematic review on metaverse education and international Chinese education was filled. Web of Science (Wos), Scopus, Science Direct, and Taylor & Francis e-Journals (PPV), there 4 databases were used in this review, and 13 articles were finally included based on the aforementioned inclusion and exclusion criteria. The main findings highlight the following two aspects of international trends in Chinese language education based on the meta-universe.

Question 1: How can Metaverse technology be used in international Chinese language education?

In this systematic review, there are six ways to apply metaverse technology in international Chinese education

1. Teaching Chinese characters using the intelligent features of metaverse technology
2. Learning Chinese characters using the immersive features of metaverse technology
3. Developing Chinese character games using metaverse technology
4. Using the social features of the metaverse
5. Using metaverse to enhance the cultural and interesting aspects of teaching Chinese characters
6. Using the metaverse for intelligent testing and evaluation

Question 2: What are the difficulties in international Chinese language teaching?

This systematic review concludes that the difficulties in Chinese language international education are mainly in the following three areas

1. Lack of Chinese learning environment
2. Pinyin of Chinese Characters
3. Strokes in Chinese Characters

Based on the findings of this review, there are more opportunities for meta-universe based Chinese international education research.

This study has some limitations. Since most of the meta-universe-based Chinese international education studies have focused on students in universities and colleges, this review does not mention the educational level as a trend. This limitation undoubtedly provides new opportunities for future research, especially in selecting different levels of meta-universe-based Chinese international education studies. Secondly, the articles in this review were obtained from high-impact journals in Web of Science and Scopus, as well as two secondary databases, namely Science Direct and Taylor & Francis e-Journals (PPV). Therefore, results may be slightly different if other databases such as Google Scholar and Dimension. Despite its limitations, this systematic review makes a significant contribution to meta-universe-based research on Chinese international education, benefits practitioners in related fields, and paves the way for future research. This review also fills the gaps in the sections on the application of metacosmic technologies in Chinese international education and the difficulties in Chinese international education, which are crucial for the sustainable development of metacosmic-based Chinese international education.

References

1. Dai, Q. (2023). Application of a Short Video Caption Generation Algorithm in International Chinese Education and Teaching. *International Journal of Web-Based Learning and*



- Teaching Technologies, 18(2), 1–19. <https://doi.org/10.4018/IJWLTT.330990>
2. Fan, J. (2023). Theory and method for evaluating the importance of college course teaching for future education: From virtual reality to metaverse. *Journal of Intelligent and Fuzzy Systems*, 44(4), 5893–5919. <https://doi.org/10.3233/JIFS-220931>
 3. Nie, Y. (2023). Application of Multimodal Multimedia Information and Big Data Technology in Teaching Chinese as a Foreign Language Course. *International Journal of Digital Multimedia Broadcasting*, 2023. <https://doi.org/10.1155/2023/2257863>
 4. Zhang, Q. (2022). Interactive Course Design and Development for Cognitively Inspired Distance International Chinese Education. *Computational Intelligence and Neuroscience*, 2022. <https://doi.org/10.1155/2022/5040920>
 5. Shen, L., & Latif, F. (2022). International Chinese Education Expert System Based on Artificial Intelligence and Machine Learning Algorithms. *Journal of Mathematics*, 2022. <https://doi.org/10.1155/2022/2160289>
 6. Zhao, J. (2022). Construction of College Chinese Mobile Learning Environment Based on Intelligent Reinforcement Learning Technology in Wireless Network Environment. *Wireless Communications and Mobile Computing*, 2022. <https://doi.org/10.1155/2022/5164430>
 7. Zhang, X. (2023). The improvement path of international Chinese education management in universities based on big data technology. *Applied Mathematics and Nonlinear Sciences*. <https://doi.org/10.2478/amns.2023.1.00335>
 8. Zhang, X. (2023). Innovation of teaching methods of international Chinese language education in universities based on artificial intelligence analysis technology. *Applied Mathematics and Nonlinear Sciences*. <https://doi.org/10.2478/amns.2023.2.00336>
 9. Shen, S. Y. (2023). Metaverse-driven new energy of Chinese traditional culture education: edge computing method. *EVOLUTIONARY INTELLIGENCE*, 16(5), 1503–1511. <https://doi.org/10.1007/s12065-022-00757-4>
 10. Yuan, J., Liu, Y. Q., Han, X. C., Li, A. P., & Zhao, L. L. (2023). Educational metaverse: an exploration and practice of VR wisdom teaching model in Chinese Open University English course. *INTERACTIVE TECHNOLOGY AND SMART EDUCATION*. <https://doi.org/10.1108/ITSE-10-2022-0140>
 11. Shu, X. Y., & Gu, X. Q. (2023). An Empirical Study of A Smart Education Model Enabled by the Edu-Metaverse to Enhance Better Learning Outcomes for Students. *SYSTEMS*, 11(2). <https://doi.org/10.3390/systems11020075>
 12. Southworth, J., Migliaccio, K., Glover, J., Glover, J., Reed, D., McCarty, C., Brendemuhl, J., & Thomas, A. (2023). Developing a model for AI Across the curriculum: Transforming the higher education landscape via innovation in AI literacy. *Computers and Education: Artificial Intelligence*, 4, 100127. <https://doi.org/https://doi.org.eresourcesptsl.ukm.remotexs.co/10.1016/j.caeai.2023.100127>
 13. Harrison, T. (n.d.). Virtual reality and character education: Learning opportunities and risks. *Journal of Moral Education*, 1–21. <https://doi.org/10.1080/03057240.2023.2206553>
 14. Page, M.J.; McKenzie, J.E.; Bossuyt, P.M.; Boutron, I.; Hoffmann, T.C.; Mulrow, C.D.; Shamseer, L.; Tetzlaff, J.M.; Akl, E.A.; Brennan, S.E.; et al. The PRISMA 2020 statement: An updated guideline for reporting systematic reviews. *BMJ* 2021, 372, 1–9.
 15. González-Albo, B.; Bordons, M. Articles vs. proceedings papers: Do they differ in research relevance and impact? A case study in the Library and Information Science field. *J. Informetr.* 2011, 5, 369–381. [CrossRef]
 16. Ramadhan, A., Suryodiningrat, S. P., & Mahendra, I. (2023). The Fundamentals of Metaverse: A Review on Types, Components and Opportunities. *JOURNAL OF INFORMATION AND ORGANIZATIONAL SCIENCES*, 47(1), 153–165.



- <https://doi.org/10.31341/jios.47.1.8>
17. Gao, H., Chong, A. Y. L., & Bao, H. J. (2023). Metaverse: Literature Review, Synthesis and Future Research Agenda. *JOURNAL OF COMPUTER INFORMATION SYSTEMS*. <https://doi.org/10.1080/08874417.2023.2233455>
 18. Kshetri, N., Rojas-Torres, D., & Grambo, M. (2022). The Metaverse and Higher Education Institutions. *IT PROFESSIONAL*, 24(6), 69–73. <https://doi.org/10.1109/MITP.2022.3222711>
 19. Asiksoy, G. (2023). PAPER Empirical Studies on the Metaverse-Based Education: A Systematic Review. *INTERNATIONAL JOURNAL OF ENGINEERING PEDAGOGY*, 13(3), 120–133. <https://doi.org/10.3991/ijep.v13i3.36227>
 20. Wu, T., & Hao, F. (2023). Edu-Metaverse: concept, architecture, and applications. *INTERACTIVE LEARNING ENVIRONMENTS*. <https://doi.org/10.1080/10494820.2023.2198567>
 21. Roy, R., Babakerkhell, M. D., Mukherjee, S., Pal, D., & Funilkul, S. (2023). Development of a Framework for Metaverse in Education: A Systematic Literature Review Approach. *IEEE ACCESS*, 11, 57717–57734. <https://doi.org/10.1109/ACCESS.2023.3283273>
 22. Zhang, X. L., Chen, Y. C., Hu, L. L., & Wang, Y. M. (2022). The metaverse in education: Definition, framework, features, potential applications, challenges, and future research topics. *FRONTIERS IN PSYCHOLOGY*, 13. <https://doi.org/10.3389/fpsyg.2022.1016300>
 23. Hussain, S. (2023). Metaverse for education - Virtual or real? *FRONTIERS IN EDUCATION*, 8. <https://doi.org/10.3389/feduc.2023.1177429>
 24. Dahan, N. A., Al-Razgan, M., Al-Laith, A., Alsoufi, M. A., Al-Asaly, M. S., & Alfakih, T. (2022). Metaverse Framework: A Case Study on E-Learning Environment (ELEM). *ELECTRONICS*, 11(10). <https://doi.org/10.3390/electronics11101616>
 25. Onu, P., Pradhan, A., & Mbohwa, C. (2023). Potential to use metaverse for future teaching and learning. *EDUCATION AND INFORMATION TECHNOLOGIES*. <https://doi.org/10.1007/s10639-023-12167-9>



053-029

RESEARCH ON ENTREPRENEURSHIP EDUCATION METHODS IN THE FORM OF DIGITAL MODULES

JI XIANGLONG^{ab}, MUHAMMAD BIN HUSSIN^a, MOHAMAD ZUBER BIN ABD MAJID^a

^a The National University of Malaysia, Malaysia.

^b Wenzhou Business College, China

ABSTRACT

With the rapid development of information technology, the digital modular form of entrepreneurial education method has significant advantages in improving educational quality and enhancing students' entrepreneurial abilities. Digital modular entrepreneurial education utilizes digital technology to integrate entrepreneurial knowledge, skills, and practical experience into a series of modules, allowing students to choose and study relevant modules based on their needs and interests. This educational approach not only breaks the traditional teaching model, making learning more flexible and efficient, but more importantly, it can truly cater to individual needs, enabling every student to find their direction in the entrepreneurial path. This article aims to explore the application of digital modular form in entrepreneurial education, analyze its impact on enhancing students' entrepreneurial abilities, and provide recommendations on how to optimize digital modular entrepreneurial education methods.

Keywords: Digital Entrepreneurship Education, Entrepreneurial Ability, Individual Needs, Modular Entrepreneurship Education.

1. Introduction

In the current era of information, the importance of entrepreneurial education is becoming increasingly prominent. Traditional entrepreneurial education models often focus on the imparting of theoretical knowledge while neglecting the cultivation of practical skills and personalized needs. The emergence of digital modular forms of entrepreneurial education methods integrates entrepreneurial knowledge, skills, and practical experience into a series of modules through digital technology to meet students' personalized needs and enhance the quality of education. In recent years, with the rapid development of digital technology, educational models have been continuously innovating. The digital modular form of entrepreneurial education method, as a new educational model, provides students with a more convenient and efficient learning approach. This article will discuss the advantages, implementation strategies, and impact on students' entrepreneurial abilities of the digital modular form of entrepreneurial education method from three perspectives.

The importance of entrepreneurial education is no longer merely about the transmission of skills or knowledge, but crucial to the success of students' future careers and even the innovation and development of society as a whole. Traditional entrepreneurial education models, despite their inherent value and status, are evidently struggling in the face of rapidly changing business environments and technological advancements. They overly emphasize the imparting of theoretical knowledge while neglecting the cultivation of practical skills and



individualized needs of each student. In this context, the emergence of digital modular forms of entrepreneurial education methods has injected new vitality into entrepreneurial education, like a clear spring. This method cleverly integrates entrepreneurial knowledge, skills, and practical experience into a series of modules using digital technology. These modules not only possess high flexibility and customization but also allow for free combinations and adjustments based on students' individualized needs. Therefore, each student can receive the most suitable entrepreneurial education plan, thus effectively enhancing their entrepreneurial abilities.

The advantages of the digital modular form of entrepreneurial education methods lie in its integration and personalization. Through digital technology, it can integrate various fragmented entrepreneurial knowledge and practical experience into an organic whole, enabling students to form a complete entrepreneurial knowledge system during the learning process. Moreover, it can be customized based on students' individual needs, ensuring that each student receives the most suitable educational plan. The implementation strategies of this educational method are also very flexible and diverse, ranging from online courses to simulated practices, project collaborations, and various forms, providing students with more convenient and efficient learning pathways. This digital modular form of entrepreneurial education method has a profound impact on students' entrepreneurial abilities. It not only helps students improve the knowledge and skills required for entrepreneurship but also fosters their innovative thinking and teamwork abilities. Through simulated practices and project collaborations, students can continuously explore and experiment in practice, accumulating valuable entrepreneurial experience. These experiences will be the most valuable assets on their future entrepreneurial path.

Therefore, the digital modular form of entrepreneurial education method is not only a supplement and improvement to traditional educational models but also a leading new educational model for the future. It can meet students' personalized needs, enhance the quality of education, and lay a solid foundation for students' entrepreneurial journey. With the continuous development of digital technology and innovation in educational models, we have reason to believe that this digital modular form of entrepreneurial education method will play a more important role in the future of the education field.

The application of digital modular entrepreneurship education method not only reflects the latest achievements in educational technology, but also represents a profound transformation of traditional entrepreneurship education models. The core idea lies in finely dividing the originally vast and complex entrepreneurial educational content into several relatively independent yet interconnected modules through digital technology. The design of these modules takes into account the systematic and complete nature of knowledge, while also considering individual differences and learning needs of students.

2. Literature review

2.1 Research Status of the Application and Impact of Digital Modules in Entrepreneurship Education

Entrepreneurship education has been a focus of various studies in recent years, with a particular interest in digital modules as a method of delivery. Abas et al. (2014) developed modules aimed at changing the mindset of post-migration workers to become entrepreneurs, providing entrepreneurship education and training, and promoting the concept of sakinah families. Kisić



et al. (2019) conducted a study on the 'Student Company' method of entrepreneurship education, which yielded positive results according to teachers involved in the program. Güngör (2021) explored obstacles to creating a Powerful Learning Environment in vocational education, highlighting issues such as outdated training modules and equipment. Pramanda et al. (2021) discussed the formation of new social capital and civic engagement through digital citizenship education, emphasizing the role of online movements and entrepreneurship. Zhang et al. (2021) focused on cultivating cognitive literacy in pan-digital media through innovative concepts and entrepreneurship education, leading to improved innovative expression methods. Akhter et al. (2022) identified factors such as digital literacy and entrepreneurship education that positively impact graduate students' digital entrepreneurial intention. Overall, these studies underscore the importance of entrepreneurship education methods, including digital modules, in fostering entrepreneurial skills and mindset among various populations.

2.2 Advancements in Research on the Current Situation, Evaluation, Effectiveness, and Stakeholders' Attitudes in Entrepreneurship Education

Entrepreneurship education has been a topic of interest in various countries, including South Africa, the United Kingdom, and Botswana. Co et al. (2006) conducted a nationwide survey in South Africa to assess the state of entrepreneurship education in higher education institutions (HEIs). The study found that traditional classroom delivery methods are commonly used for teaching and assessment, with research in entrepreneurship perceived as less rigorous compared to other management disciplines. Similarly, McKeown et al. (2006) reviewed the provision of entrepreneurship education in the United Kingdom and found that it is varied, with courses on entrepreneurship and innovation being offered. Assessment practices in entrepreneurship education have also been a focus of research. Pittaway et al. (2012) highlighted the lack of empirical research on student assessment practices in entrepreneurship education and emphasized the need for further investigation in this area. Arasti et al. (2012) conducted qualitative studies to identify appropriate teaching methods for entrepreneurship education, specifically focusing on the "business planning" course. The effectiveness of entrepreneurship education has been a subject of inquiry, with Lekoko et al. (2012) examining entrepreneurship education at universities in Botswana. The study aimed to evaluate the effectiveness of entrepreneurship education in contributing to economic growth and development. Furthermore, Lorz et al. (2013) conducted a systematic review of impact studies in entrepreneurship education and identified methodological deficiencies that question the positive impact of entrepreneurship education. Rideout et al. (2013) also critiqued the empirical literature on the effects of university-based entrepreneurship education, highlighting methodological weaknesses in existing studies. Additionally, Fellnhofer et al. (2015) examined attitudes towards entrepreneurship education among various stakeholders in Europe, calling for more research on teaching methods to enhance skills in reacting to entrepreneurial opportunities. In conclusion, research on entrepreneurship education methods has focused on assessing the state of entrepreneurship education, evaluating teaching and assessment practices, examining the effectiveness of entrepreneurship education, and exploring attitudes towards entrepreneurship education among different stakeholders. Further research is needed to address methodological deficiencies and enhance the impact of entrepreneurship education.

2.3 Research on Entrepreneurship Education Driven by Digital Technology and the Modern Business Landscape

Entrepreneurship education has been recognized as a crucial aspect of preparing individuals to navigate the complexities of the modern business landscape. In recent years, there has been a



growing emphasis on utilizing digital technology to enhance entrepreneurship education methods. Abas et al. (2014) highlighted the importance of changing the mindset of migrant workers post-migration to transition from consumer culture to becoming productive entrepreneurs. They developed modules focusing on changing workers' mental patterns, providing entrepreneurship education and training, and promoting the concept of sakinah families through education and training. Prastyaningtyas et al. (2019) emphasized the role of higher education institutions in equipping students with entrepreneurship skills through the integration of digital technology. They underscored the significance of universities in preparing students to face the challenges of the evolving job market. Kisić et al. (2019) conducted a study on the 'Student Company' method of entrepreneurship education, which yielded positive results in developing entrepreneurial skills among students. Ramchander (2019) examined entrepreneurship education frameworks at traditional South African universities and found that there were modules focusing on entrepreneurship at the undergraduate level, albeit with low credit values. The study also highlighted the need for more structured entrepreneurship education initiatives to foster entrepreneurship among students. Herlina et al. (2021) explored the perceptions of building students' social entrepreneurship in higher education, revealing that while students had good digital innovation capabilities, their intentions to engage in social entrepreneurship were not substantial. Zhang et al. (2021) conducted a study on integrating media literacy and entrepreneurship education to enhance students' cognitive literacy in digital media. The results showed significant improvements in students' ability to develop innovative concepts and entrepreneurship education through dynamic expression. Akhter et al. (2022) identified factors such as digital entrepreneurial self-efficacy, digital literacy, entrepreneurship education, innovativeness, and creativity as key determinants of digital entrepreneurial intention among university graduate students. Overall, the literature reviewed underscores the importance of incorporating digital modules into entrepreneurship education to equip students with the necessary skills and mindset to thrive in the ever-changing business landscape. The studies emphasize the need for structured and innovative approaches to entrepreneurship education to foster entrepreneurial spirit among students.

3. The application of digital modular entrepreneurship education method

The contents of these modules are diverse, covering various aspects from basic entrepreneurial theory knowledge to practical entrepreneurial skills, and specific entrepreneurial practical experience. Students can flexibly choose modules that suit their interests, professional backgrounds, and career plans for learning. This personalized learning approach not only enhances students' learning efficiency but also boosts their motivation for learning.

Digital modular entrepreneurship education also has significant advantages. Firstly, the use of digital technology makes it more convenient to access and share educational resources, allowing students to learn anytime, anywhere, breaking the traditional constraints of time and space in classrooms. Secondly, modular design makes educational content more focused and in-depth, helping students develop a deep understanding and mastery in a particular field. Lastly, digital modular entrepreneurship education method provides students with more interactive and collaborative opportunities, enabling them to learn and progress collectively with peers through online discussions, project collaborations, etc.

The application of digital modular entrepreneurship education method not only enhances the flexibility and personalization of education but also provides students with broader and deeper learning experiences. This innovative educational model is of great significance in cultivating



entrepreneurial talents with innovative spirit and practical abilities. The core of the digital modular entrepreneurship education method lies in using digital technology to divide entrepreneurial education content into several independent modules. These modules cover various aspects of entrepreneurial knowledge, skills, and practical experience, allowing students to select relevant modules based on their needs and interests.

Table 3-1 Application table of digital modular entrepreneurship education method

Module type	Content	Superiority
Entrepreneurship knowledge	Basic theoretical knowledge of entrepreneurship	Improve students' learning efficiency and motivation
Entrepreneurship skills	Practical entrepreneurial skills	Form a deep understanding and mastery
Entrepreneurship practice experience	Specific entrepreneurial practice experience	Provide more opportunities for interaction and cooperation

Entrepreneurship education in digital modular form has the following advantages:

3.1 Personalized learning

The modular form of numbers allows students to choose learning modules based on their needs and interests, thereby achieving personalized learning. This learning method is more in line with students' actual needs, helping to increase motivation and engagement in learning.

Personalized learning is a learning model that caters to students' individual needs and interests, and digital modular forms provide strong technological support for the realization of this model. In digital modular learning, students are no longer passive recipients in the traditional sense but become the leaders of learning. They can independently select learning modules that suit their learning progress, interests, and needs, thus constructing a learning path that meets their actual needs.

Table 3-2 Personalized learning form

learning style	Characteristic
Digital modular learning	Students can choose learning modules according to their own needs and interests to realize personalized learning
Personalized learning	In line with students' personalized needs and interests, students become the leader of learning and choose the learning module independently
Digital modular learning	Improve students' learning enthusiasm and participation, and enhance the pertinacity and effectiveness of learning

Personalized learning not only aligns with the emphasis on student subjectivity in contemporary educational concepts but also better meets students' individualized needs in the knowledge acquisition process. Each student is unique, with different learning styles, interests, and learning speeds. Digital modular learning allows them to demonstrate their subjectivity in the learning process, thereby enhancing the targetedness and effectiveness of learning.



Table 3-3 Characteristics of digital modular learning

Characteristic	Description
Student-led	Students can choose suitable learning modules according to their own learning progress, interests and needs
Personalized learning path	Students can build learning paths that meet their actual needs
Increase enthusiasm and participation	Students can be more active in learning and experience the fun and sense of achievement of learning
Interactive opportunities	Students can discuss questions and share their experiences through the interaction with their peers, teachers or learning resources

The modular learning approach in digital format not only enhances students' motivation and engagement but also empowers them to take control of the learning content and pace, enabling a more active involvement in learning, experiencing the joy and sense of achievement in the process. Additionally, digital modular learning provides students with more interactive opportunities to engage with peers, teachers, and learning resources, facilitating collaborative discussions, knowledge sharing, and deeper understanding and mastery of the subject matter.

The personalized learning in modular digital format not only aligns with students' practical needs but also contributes to boosting their motivation and engagement. This learning method not only fosters students' self-directed learning abilities but also allows them to gain a greater sense of accomplishment and satisfaction during the learning process, thereby achieving a more comprehensive and in-depth learning experience.

Table 3-4 Digital Modular Learning Advantages Table

Superiority	Characteristic
It meets the actual needs of students	Digital modular learning is in line with the actual needs of students and helps to improve learning enthusiasm and participation
Improve learning enthusiasm and participation	Digital modular learning helps to improve students' enthusiasm and participation in learning, and enhance the pertinacity and effectiveness of learning
Comprehensive and in-depth study	Digital modular learning helps to cultivate students' self-directed learning ability, so that they can get a greater sense of achievement and satisfaction in the learning process

3.2 Flexible and efficient

The modular form of digital entrepreneurship education breaks free from the constraints of time and location, allowing students to learn anytime, anywhere. The modular design enhances efficiency, enabling students to learn at their own pace. In today's rapidly changing era, education has transcended traditional classroom settings. The emergence of digital modular entrepreneurship education offers unprecedented flexibility and efficiency. This form of



education completely liberates students from time and space constraints, allowing them to explore the ocean of knowledge at their convenience, whether at the break of dawn or in the quiet of night. Learning is no longer a fixed task but a way of life.

Moreover, digital modular entrepreneurship education enhances learning efficiency. Traditional educational models often employ a one-size-fits-all approach, struggling to meet the diverse learning needs of each student. Conversely, modular design allows students to freely choose learning content and pace based on their individual circumstances, making learning more personalized and autonomous. Students can delve deep into areas they excel in, strengthen weak points, and progress at their own pace, truly catering to individual needs.

Table 3-5 Advantages of digital modular entrepreneurship education

Digital module	Superiority
Flexible and efficient	Unlimited by time and place, students can learn anytime and anywhere. Modular design makes learning more efficient, and students can learn according to their own progress and pace.
Personalized learning	The modular design allows students to freely choose the content and progress of learning according to their own actual situation, so that learning becomes more personalized and autonomous.
Rich in learning resources	Students can have access to high-quality educational resources from all over the world, communicate and interact with the world's top entrepreneurs and experts, and constantly expand their vision and way of thinking.

The digital modular form of entrepreneurship education also provides students with a wealth of learning resources. With the support of the internet, students can access high-quality educational resources from around the world, engage with global top entrepreneurs and experts, and expand their horizons and ways of thinking. This interdisciplinary learning experience not only enhances students' overall qualities but also provides them with more inspiration and enlightenment on their entrepreneurial journey. With its flexible and efficient characteristics, digital modular entrepreneurship education creates a more open, diverse, and liberated learning environment for students. It not only makes learning easier and more enjoyable but also helps each student find their learning path, achieving self-transcendence and growth.

3.3 Practice-oriented

The entrepreneurship education in a digital modular form emphasizes the cultivation of practical abilities. Through simulation practices, case studies, and other methods, students are able to learn and master entrepreneurial knowledge and skills through practical application. Practical-oriented educational approaches, particularly in the context of digital modular entrepreneurship education, play a crucial role. The core of this educational method lies in nurturing students' practical abilities, enabling them to acquire the necessary knowledge and skills for entrepreneurship through hands-on experience. Through simulation practices, students can experiment with various entrepreneurial strategies and methods in a relatively safe environment, deepening their understanding and enhancing their skills through real-world application. Case studies provide students with the opportunity to delve into real entrepreneurial cases, drawing lessons and experiences to enrich their entrepreneurial knowledge base further.



Table 3-6 Practice-oriented digital modular entrepreneurship education

educational mode	Core	superiority	Effect
Simulation practice	Cultivate students' practical ability	Try entrepreneurial strategies and methods in a relatively safe environment	Deepen understanding and improve skills
case analysis	Enrich the entrepreneurial knowledge base	Dig deep into real business cases	Learn from the experience and lessons learned
Digital modular form	Flexible and personalized	Students can select the modules according to their interests and needs	Targeted learning, faster to of key knowledge and skills

The digital modular form makes entrepreneurship education more flexible and personalized. Students can choose modules based on their interests and needs for in-depth study, facilitating faster mastery of key knowledge and skills through targeted learning. Additionally, the digital modular format enhances the efficiency of entrepreneurship education, allowing students to learn anytime, anywhere, making use of fragmented time to improve learning effectiveness. Practical-oriented digital modular entrepreneurship education not only helps students master entrepreneurial knowledge and skills through practice but also cultivates their innovative thinking and problem-solving abilities. This educational approach aligns with modern educational concepts and meets society's demand for entrepreneurial talents, holding significant importance in nurturing future entrepreneurs.

3.4 Personalized learning

The entrepreneurial education method in the form of digital modules can provide personalized learning content and progress based on students' needs and abilities, meeting the diverse needs of different students. In today's highly information-based society, personalized learning has become a hot topic in the field of education. Particularly in the field of entrepreneurial education, a new educational method presented in the form of digital modules is gradually emerging. This method not only fully utilizes modern technological means but, more importantly, it fully respects the students' subjective position and personalized needs.

The entrepreneurial education method in the form of digital modules, through carefully designed learning modules, breaks down and reorganizes the core knowledge and skills of entrepreneurial education into a series of independent yet interrelated learning units. These learning units can be freely selected based on students' interests and needs, or flexibly adjusted according to their abilities and progress. This flexibility and autonomy enable each student to customize their own learning path according to their individual circumstances. The realization of personalized learning relies on the application of advanced technologies such as big data and artificial intelligence. By collecting and analyzing students' behavioral data during the learning process, the system can accurately assess students' learning status and ability levels, thereby recommending the most suitable learning content and progress. This intelligent recommendation mechanism not only helps students master knowledge more efficiently but also inspires their interest and motivation for learning.



Table 3-7 Table of entrepreneurship education methods in the form of a digital module

module	Characteristic method
Personalized learning	Provide personalized learning content and progress according to students' needs and abilities
Digital module form	Carefully designed learning modules, split and reorganize the core knowledge and skills of entrepreneurship education
Flexibility and autonomy	Students can freely choose learning units according to their interests and needs, and adjust them flexibly according to their abilities and schedule
Big data and artificial intelligence applications	Collect and analyze student behavior data, and recommend the most appropriate learning content and progress
Cultivate practical ability and innovative spirit	Encourage students to use their imagination and creativity by simulation practice and case analysis
Meet the needs and abilities of different students	Provide a learning environment full of challenges and opportunities to help students grow and develop on their entrepreneurial path

The entrepreneurial education method in the form of digital modules also focuses on cultivating students' practical abilities and innovative spirit. During the learning process, students can apply the knowledge they have learned to practical situations through simulation practices, case studies, and other methods, deepening their understanding and mastery of the knowledge. At the same time, this method encourages students to use their imagination and creativity, propose their own insights and solutions, and cultivate their awareness and abilities for innovation. The entrepreneurial education method in the form of digital modules is a personalized learning approach that is rich in depth and breadth. It not only meets the needs and abilities of different students but, more importantly, it provides students with a challenging and opportunistic learning environment, helping them continuously grow and develop on the entrepreneurial path.

3.5 Resource sharing

The entrepreneurial education method in the form of digital modules can achieve the sharing of educational resources, break geographical and time constraints, and benefit more students. The entrepreneurial education method in the form of digital modules not only represents the innovation of educational technology but also demonstrates a significant transformation in the distribution and utilization of educational resources at a deeper level. Through digital means, resources and knowledge in entrepreneurial education can flow seamlessly without being limited by physical space. This form of education, like opening a door to a vast ocean of knowledge, allows students to access cutting-edge entrepreneurial concepts and practical experiences as long as they have internet connectivity, regardless of their location. More importantly, the digital module form of entrepreneurial education breaks the constraints of time. Traditional education is often limited by fixed class times and semester schedules, while digital education allows students to learn at their own pace and schedule.

Table 3-8 Advantages of entrepreneurship education methods in the form of digital module



module	Advantages of the specific method
Sharing of educational resources	Break the geographical and time restrictions to benefit more students
Innovation in educational technology	Show the change in the allocation and utilization of educational resources
The flow of knowledge	Through digital means, knowledge and resources can flow seamlessly
Learning flexibility	Students can study according to their own pace and schedule
Efficient use of educational resources	Avoid the waste and redundancy of resources
equal access to education	Provide equal educational opportunities for students with geographically remote locations or limited economic conditions
Promote the popularization of education	Promote the popularization of knowledge and cultivate more excellent talents with entrepreneurial spirit and ability

This flexibility not only provides students with greater autonomy in learning but also allows educational resources to be more efficiently utilized, avoiding waste and redundancy. In this way, more students benefit, whether they come from bustling urban areas or remote rural regions. Digital module entrepreneurial education not only promotes the dissemination of knowledge but also provides equal educational opportunities for students in remote or economically disadvantaged areas. It is a strong complement to traditional educational models and a powerful tool for promoting educational equity and accessibility. With the advancement of digitization, we have reason to believe that this form of entrepreneurial education will play a more important role in the future, cultivating more outstanding talents with entrepreneurial spirit and capabilities.

3.6 Self-directed learning

The entrepreneurial education method in the form of digital modules encourages students to engage in independent learning, enhances their self-learning capabilities, and problem-solving skills. In today's era of information explosion, traditional educational models struggle to meet the diverse knowledge and skill needs of students. Particularly in the field of entrepreneurial education, the singular classroom teaching method is inadequate to adapt to the rapidly changing business environment. Therefore, independent learning has emerged as a significant innovation in the education sector, especially in digital module-based entrepreneurial education methods, highlighting its crucial importance. The digital module-based entrepreneurial education method systematizes and modularizes complex entrepreneurial knowledge, enabling students to flexibly select learning modules based on their interests and abilities, thus achieving genuine personalized learning. This approach greatly stimulates students' enthusiasm for learning, encouraging them to actively explore, experiment, and continuously enhance their independent learning and problems-solving skills.

The cultivation of independent learning abilities not only aids students in mastering entrepreneurial knowledge but also helps them better adapt to the constantly evolving work environment in their future careers. Through independent learning, students can think and solve



problems more independently, demonstrating higher professional competence and competitiveness in the workplace. Simultaneously, the digital module-based entrepreneurial education method provides students with a broad practical platform. Through simulated entrepreneurship, project practices, and other methods, students can apply their acquired knowledge to practical scenarios, deepening their understanding and mastery of entrepreneurial knowledge. This practical learning approach not only assists students in mastering entrepreneurial skills but also allows them to accumulate experience in practice, laying a solid foundation for their entrepreneurial journey in the future. With its unique advantages, the digital module-based entrepreneurial education method offers students a more flexible and autonomous learning environment. In this setting, students can not only acquire rich entrepreneurial knowledge but also develop their independent learning and problem-solving skills. Undoubtedly, this is a valuable asset for their future professional careers.

Table 3-9 Entrepreneurship education methods in the form of digital module

module	Content
autonomic learning	Improve the ability of independent learning and solving problems
Digital module form	Systematize and modularize entrepreneurial knowledge to realize personalized learning
Practice platform	Simulate entrepreneurship, project practice, and apply knowledge to practice
superiority	Flexible and independent learning environment, exercise the ability of independent learning and problem solving

4. The impact of digital modular entrepreneurship education on students' entrepreneurial abilities

4.1 Multidimensional enhancement of entrepreneurial abilities through digital modular entrepreneurship education

The impact of digital modular entrepreneurship education on students' entrepreneurial abilities is profound and multidimensional. This influence is not only reflected in the enhancement of students' entrepreneurial skills and knowledge, but also manifests in the strengthening of their innovative thinking, market insight, and teamwork capabilities. Firstly, digital modular education enables students to grasp core entrepreneurial knowledge and skills more quickly and efficiently through systematic course design and modular teaching content. This educational approach emphasizes practicality and operability, allowing students to find a balance between theoretical learning and practical application, thereby better transforming theoretical knowledge into practical operational abilities. Secondly, digital modular entrepreneurship education focuses on nurturing students' innovative thinking and problem-solving skills. In the modular learning process, students constantly face new challenges and problems, using independent thinking and innovative thinking to find solutions.

This process not only hones students' innovative thinking but also cultivates their ability to quickly identify entry points when facing complex problems. Digital modular entrepreneurship education also emphasizes the cultivation of market insight and teamwork skills. Throughout



the learning process, students need to pay attention to market dynamics and industry trends, learning to analyze and solve problems from a market perspective. At the same time, they need to play their role in the team and collaborate with others to complete tasks. This educational model allows students to develop market sensitivity and teamwork skills in practice, laying a solid foundation for their future entrepreneurial path. The impact of digital modular entrepreneurship education on students' entrepreneurial abilities is comprehensive and far-reaching. It not only enhances students' entrepreneurial skills and knowledge but also nurtures their innovative thinking, market insight, and teamwork capabilities. This educational approach helps students better cope with various challenges and opportunities on their future entrepreneurial journey, realizing their entrepreneurial dreams.

Table 4-1 Impact of digital modular entrepreneurship education on students' entrepreneurial ability

Influence aspects	Embody
Entrepreneurial skills and knowledge	Through systematic curriculum design and modular teaching content, students can master the core knowledge and skills needed for entrepreneurship more quickly and more efficiently.
innovative thinking	Attention should be paid to cultivating students' innovative thinking and problem-solving ability, so that students can find a balance between theoretical learning and practical operation, so as to better transform theoretical knowledge into practical operation ability.
Market insight	Emphasize the cultivation of market insight and teamwork ability, let students pay attention to the market dynamics and industry trends, learn to analyze and solve problems from the perspective of the market.
Team collaboration ability	In practice, students can cultivate their market sensitivity and teamwork ability, which lays a solid foundation for their future entrepreneurship.

4.1.1 Accumulation of entrepreneurial knowledge

Through the digital modular form of entrepreneurial education, students can systematically learn and master theoretical knowledge and practical experience related to entrepreneurship, laying a solid foundation for future entrepreneurial activities. The accumulation of knowledge is an indispensable cornerstone on the path of entrepreneurship. With digital modular entrepreneurial education, students can explore the theory and practice of entrepreneurship in a systematic and organized manner. This educational approach breaks down complex entrepreneurial knowledge into multiple modules, each focusing on a specific area or topic, allowing students to gradually establish a comprehensive entrepreneurial knowledge system. This modular learning approach not only helps students master the theoretical knowledge required for entrepreneurship but also enables them to transform theoretical knowledge into practical experience through projects, case studies, and other methods. This combined learning approach of theory and practice allows students to continuously accumulate experience and skills during the learning process, preparing them adequately for future entrepreneurial activities.



Table 4-2 Entrepreneurial Knowledge Accumulation Table

module	Main knowledge accumulation content
Digital modular form	Systematically learn and master the theoretical knowledge and practical experience related to entrepreneurship
speculative knowledge	Theoretical knowledge needed to start
hands-on	Through practical projects, case analysis and other ways, the theoretical knowledge into practical experience
flexibility	Students can choose suitable modules for learning according to their own interests and needs
creative spirit	Cultivate their innovative spirit and practical ability

Digital modular entrepreneurial education also offers great flexibility. Students can choose modules that suit their interests and needs, better meeting their individualized requirements. Furthermore, this educational format allows students to select relevant modules at different stages of entrepreneurship according to their needs, making learning more practical and useful. Through digital modular entrepreneurial education, students can systematically learn and master theoretical knowledge and practical experience related to entrepreneurship, establishing a strong foundation for future entrepreneurial activities. This educational approach not only enhances students' entrepreneurial abilities and qualities but also cultivates their innovative spirit and practical skills, injecting powerful drive into their future development.

4.1.2 Enhancement of entrepreneurial skills

The entrepreneurial education in a digital modular form focuses on the cultivation of practical skills, allowing students to learn and master entrepreneurial skills through simulated practices, case studies, and other methods, enhancing their entrepreneurial capabilities. The advancement of entrepreneurial skills has a profound impact on digital modular entrepreneurial education. In today's digital and informational era, entrepreneurial education is gradually moving away from traditional theoretical teaching methods towards a more practical and targeted digital modular form. This educational model not only emphasizes the imparting of theoretical knowledge but also places a strong emphasis on the development of practical skills, providing entrepreneurs with a comprehensive and multi-faceted learning experience. The core concept of digital modular entrepreneurial education lies in "learning through practice, growing through practice." Through simulated practices, case studies, and other teaching methods, students experience firsthand the various aspects of entrepreneurship in real or simulated entrepreneurial environments, enabling them to better understand and master entrepreneurial skills. This educational approach not only allows students to accumulate valuable practical experience but also nurtures their innovative thinking and problem-solving abilities.

Digital modular entrepreneurial education also possesses high flexibility and customizability. Depending on different entrepreneurial fields and stages, educators can adjust educational content and modules flexibly to ensure that students acquire the most practical and cutting-edge knowledge and skills. This personalized educational approach enables each student to tailor their entrepreneurial learning path based on their interests and needs. In the long run, digital modular entrepreneurial education has a profound impact on enhancing entrepreneurs'



capabilities. It not only helps students acquire the necessary basic entrepreneurial skills but also fosters their market insight, teamwork skills, and resilience. These abilities are crucial in the entrepreneurial process, enabling entrepreneurs to stand out in intense market competition and achieve entrepreneurial success. Digital modular entrepreneurial education is an education model with far-reaching influence. Through practical teaching methods, it cultivates students' entrepreneurial skills and practical abilities, laying a solid foundation for their entrepreneurial journey. With the continuous development and improvement of this educational model, it is believed that more and more entrepreneurs will benefit from it in the future, making greater contributions to the society's innovation and progress.

Table 4-3 Digital modular entrepreneurship education table

educational pattern	Characteristic	Influence
Digital modular entrepreneurship education	Pay attention to the cultivation of practical ability, through simulation practice, case analysis and other ways, let students learn and master entrepreneurial skills in practice, improve their entrepreneurial ability.	It provides entrepreneurs with all-round and multi-angle learning experience, cultivates the ability of innovative thinking and problem solving, and improves the ability of entrepreneurs.

4.1.3 Stimulation of entrepreneurial awareness

The entrepreneurial education method in digital modular form allows students to choose learning modules based on their interests and needs, which helps to stimulate students' entrepreneurial awareness and innovative spirit. Stimulating entrepreneurial awareness is a key task in the modern educational system, especially in a rapidly changing, digitally driven era. Traditional educational models often focus on knowledge impartation and skills training, overlooking student initiative and creativity. The digital modular form of entrepreneurial education breaks this norm by enabling students to autonomously select learning modules based on their interests, professional background, and personal needs, thus creating personalized learning paths. This approach not only respects individual differences among students but also encourages them to actively explore, practice, and innovate. Students can delve into a specific area, exploring its mysteries and challenges according to their interests and needs during the learning process. This proactive learning method helps cultivate students' innovative thinking and entrepreneurial spirit, enabling them to better adapt to changes, seize opportunities, and become true innovators and leaders in their future careers.

Table 4-4 Entrepreneurial awareness was published

content	Description
Digital modular form of entrepreneurship education method	Allowing students to choose learning modules according to their own interests and needs helps to stimulate students' entrepreneurial awareness and innovative spirit.
Stimulate entrepreneurial awareness	A key task in the modern education system, especially in a rapidly changing digital age.
Traditional education mode	Focus on the indoctrination of knowledge and skill training, while ignoring the initiative and innovation of students.



Digital modular form of entrepreneurship education method	It breaks the traditional education model, allowing students to choose learning modules according to their own interests, professional background and personal needs, so as to build a personalized learning path.
Practical learning style	It is helpful to cultivate students' practical operation ability and problem-solving ability, and to lay a solid foundation for their future entrepreneurial road.

The digital modular form of entrepreneurial education also provides students with rich resources and tools, allowing them to continuously experiment, learn, and grow in practice. This practical learning approach helps develop students' practical skills and problem-solving abilities, laying a solid foundation for their entrepreneurial journey in the future. Therefore, the digital modular form of entrepreneurial education not only helps stimulate students' entrepreneurial awareness and innovative spirit but also serves as an effective means to cultivate future innovators and leaders. It enables students to acquire knowledge and skills, as well as develop their innovative thinking and entrepreneurial spirit, preparing them adequately for their future careers.

4.2 Implementation strategies of entrepreneurship education in digital modular form

4.2.1 Building a comprehensive curriculum system

Developing a scientific and systematic entrepreneurial education curriculum system is essential to ensure that the curriculum covers entrepreneurial knowledge, skills, and qualities comprehensively. In order to cultivate future leaders with entrepreneurial spirit and capability, establishing a comprehensive and in-depth curriculum system is crucial. This system should not only encompass fundamental entrepreneurial knowledge but also integrate practical skills and necessary personal qualities development. Firstly, entrepreneurial education courses must be built upon a scientific and systematic foundation to ensure that students can understand the entire process of entrepreneurship holistically. From market research and business plan development, to financing, team building, product development, and market promotion, each stage should have corresponding course content as support. Courses should also focus on key areas such as entrepreneurial law, financial management, providing students with a comprehensive knowledge base. Secondly, course content should emphasize practicality and operability. While theoretical knowledge is important, the transformation of knowledge into practical operational skills is crucial. Therefore, courses should include rich practical components such as case studies, simulated entrepreneurship, field visits, allowing students to learn and grow through practice. Thirdly, entrepreneurial education should also focus on the cultivation of personal qualities. Entrepreneurship requires not only intelligence and courage, but also perseverance, good communication skills, and teamwork spirit. Courses should help students enhance these necessary personal qualities through lectures, seminars, team projects, and other forms.



Table 4-5 Curriculum system of entrepreneurship education

curriculum system	System specific content
Entrepreneurship knowledge	Market research, business plan formulation, financing, team building, product development, marketing promotion, entrepreneurship law, financial management, etc
Practical skills	Case analysis, simulated entrepreneurship, field investigation, etc
personal quality	Tough will, good communication skills, team spirit

Constructing a sound entrepreneurial education curriculum system is a systematic project that requires the integration of various resources and efforts. Only in this way can entrepreneurial talents with both theoretical knowledge and practical skills be truly nurtured, contributing to the innovation and development of society.

4.2.2 Strengthening practical teaching

By utilizing practical teaching elements such as case analysis and simulated entrepreneurship, students' practical abilities and innovative thinking can be enhanced. Strengthening practical teaching is undoubtedly a crucial component in higher education. Practical teaching not only aids students in translating theoretical knowledge into practical skills but also serves as a vital means to cultivate their innovative thinking and problem-solving abilities. Traditional educational models often focus on imparting theoretical knowledge while neglecting the development of students' practical skills and innovative thinking. Therefore, a profound reform and innovation in practical teaching are necessary to better cater to the demands of modern society for talents. Firstly, through case analysis, students can interact with real-world business environments, comprehend the actual operations of enterprises, and thereby deepen their understanding of theoretical knowledge. Case analysis not only assists students in problem analysis and resolution but also stimulates their innovative thinking, enabling them to approach issues from multiple perspectives and find innovative solutions. Secondly, simulated entrepreneurship is an extremely challenging practical teaching segment. Throughout the process of simulated entrepreneurship, students are required to assume the role of entrepreneurs, develop business plans, raise funds, manage teams, and address market risks, among other tasks. This process not only hones students' practical abilities but also fosters their spirit of teamwork and innovative thinking. Through simulated entrepreneurship, students can gain a better grasp of the entrepreneurial process and challenges, preparing themselves adequately for future career paths. In addition to case analysis and simulated entrepreneurship, other practical teaching elements such as field visits and corporate internships can also be introduced. These practical teaching segments enable students to engage with authentic business environments, interact and learn from industry professionals, thus gaining a deeper insight into industry dynamics and trends. Simultaneously, these practical teaching elements assist students in establishing interpersonal networks, laying a solid foundation for their future career development. Strengthening practical teaching stands as a significant means to cultivate students' practical abilities and innovative thinking.



Table 4-6 Link and effect table of practical teaching

Practical teaching link	Practical teaching effect
case analysis	Deepen the understanding of theoretical knowledge, stimulate innovative thinking, learn to think about problems from multiple angles, and find innovative solutions
Simulation entrepreneurship	Exercise practical ability, cultivate team spirit and innovative thinking, and better understand the process and challenges of entrepreneurship
Field investigation, enterprise internship, etc	Contact with the real business environment, communicate and learn from the industry insiders, understand the industry trends and development trends, and establish interpersonal network

Through case analysis, simulated entrepreneurship, and other practical teaching elements, we can facilitate students in gaining a better understanding of business environments, honing practical skills, nurturing innovative thinking, and preparing adequately for their future professional endeavors.

4.2.3 Enhancing teacher training

To enhance the quality of entrepreneurship education, it is crucial to provide professional training for entrepreneurship education teachers to improve their professional competence and teaching abilities. Deepening the cultivation of teaching staff involves offering systematic and professional training for entrepreneurship education teachers, comprehensively enhancing their professional competence and teaching abilities. With the continuous development of society, entrepreneurship education has gradually become an important component of the education system. It not only nurtures students' entrepreneurial thinking and practical skills but also lays a solid foundation for their future career paths. However, for entrepreneurship education to truly fulfill its intended role, the key lies in the professional competence and teaching abilities of teachers. Therefore, strengthening teacher training, especially tailored to entrepreneurship education teachers, is particularly important.

In order to comprehensively enhance the professional competence of entrepreneurship education teachers, it is necessary to establish a complete and systematic training system. This includes training on the fundamental concepts of entrepreneurship education, teaching methods, specific teaching cases, and practical experiences. Through such training, teachers can deeply understand the core value of entrepreneurship education, master effective teaching methods, and better guide students in problem identification and solving, cultivating their innovation thinking and practical skills. Additionally, emphasis should be placed on improving teachers' teaching abilities, including teaching design, classroom management, and student assessment. Through training, teachers can learn how to design more engaging courses, manage classrooms more effectively, and provide more accurate assessments of students' learning outcomes. In this way, teachers can not only better fulfill their teaching tasks but also offer students a higher-quality learning experience.



Table 4-7 Teacher training Form for entrepreneurship Education

Training content	Target
The basic concept of entrepreneurship education	Understand the core values of entrepreneurship education deeply
teaching method	Master effective teaching methods
Teaching cases and practical experience	All-round training to improve professional quality
instructional design	Design of even more attractive courses
Classroom management	To manage the classroom more effectively
student assessment	And to evaluate students' learning outcomes more accurately

Enhancing teacher training is key to improving the quality of entrepreneurship education. By providing systematic and professional training, entrepreneurship education teachers' professional competence and teaching abilities can be comprehensively enhanced, contributing to the cultivation of more outstanding talents with innovative spirit and practical skills.

4.2.4 Expanding cooperation channels

To enhance students' practical capabilities and entrepreneurial spirit comprehensively, it is imperative to actively expand collaboration channels and establish solid and effective partnerships with enterprises, industry organizations, and similar entities. This collaboration goes beyond superficial exchanges to deep integration. Through close cooperation with various enterprises and industry organizations, students can be presented with more authentic and challenging practical opportunities. These experiences will assist students in integrating theoretical knowledge with practical work, thereby enhancing their understanding and application of the acquired knowledge. Furthermore, such partnerships will provide students with valuable entrepreneurial resources. Enterprises and industry organizations can offer multifaceted support in terms of funding, technology, market access, and more, aiding students in realizing their entrepreneurial aspirations. Collaborating with enterprises and industry organizations also exposes students to industry experts and successful entrepreneurs, from whom they can learn valuable entrepreneurial experiences and wisdom. Expanding collaboration channels and establishing close partnerships with enterprises, industry organizations, and the like are crucial pathways to enhancing students' practical capabilities and entrepreneurial spirit. We are committed to continuing this endeavor to offer students more and better practical opportunities and entrepreneurial resources.

Table 4-8 Table of expanding cooperation channels

Cooperation object	The purpose of cooperation	Cooperation content
Enterprise	Provide practical opportunities	Cooperation projects, internship opportunities, etc
Industry organizations	Provide entrepreneurial resources	Capital, technology, market support, etc



5. Suggestions for optimizing digital modular entrepreneurship education methods

In the process of digital modular entrepreneurship education, emphasis should be placed on the cultivation of practical and applied abilities. By introducing practical cases, simulating entrepreneurial environments, and other methods, students can master entrepreneurial knowledge and skills through practical operations, enhancing problem-solving abilities. Entrepreneurship involves knowledge and skills from various fields, therefore interdisciplinary integration should be strengthened in digital modular entrepreneurship education. By integrating knowledge and methods from different disciplines to form comprehensive educational modules, students can develop comprehensive entrepreneurial literacy. Each student has different interests and abilities, hence personalized learning paths should be provided in digital modular entrepreneurship education. By designing modules of different difficulties and directions to meet personalized needs, students' learning motivation and innovative spirit can be encouraged. In digital modular entrepreneurship education, mentor guidance and feedback are crucial for student development. Establishing a mentor team to provide regular guidance, Q&A services, timely feedback, and suggestions to students to help them solve problems encountered during the entrepreneurial process is essential.

With the rapid development of digital technology, digital modular entrepreneurship education methods should also keep pace. Regular updates and optimization of educational content and methods, introducing the latest entrepreneurial concepts and practical experiences, ensure the continuous improvement of educational quality. Collaboration with the industry can provide students with more practical opportunities and entrepreneurial resources. Inviting entrepreneurs, investors, and other industry professionals to participate in teaching, share entrepreneurial experiences and insights, as well as providing internship and employment opportunities for students can be beneficial. In addition to classroom teaching, establishing a complete entrepreneurial ecosystem including incubators, entrepreneurial competitions, entrepreneurial training, etc., can provide students with more entrepreneurial resources and support, promoting the deep development of entrepreneurial practices. In digital modular entrepreneurship education, emphasis should be placed on cultivating students' innovative thinking and entrepreneurial spirit. By designing challenging tasks and projects to stimulate students' creativity and imagination, their innovative thinking and problem-solving abilities can be nurtured. With the continuous development and popularization of digital technology, digital modular entrepreneurship education methods play an increasingly important role in cultivating students' entrepreneurial capabilities and improving educational quality.

Table 5-1 Digital Modular Entrepreneurship Education

propose	concrete content
Pay attention to the cultivation of practice and application ability	Introduce actual cases, simulate the entrepreneurial environment, and improve the ability to solve problems
Strengthen the interdisciplinary integration	Integrate the knowledge and methods of different disciplines to form a comprehensive education module
Provide personalized learning paths	Design modules with different difficulties and directions to meet the personalized needs of students
Establish a mentor team	Provide regular guidance and q & A services, and give students timely feedback and suggestions



All things change, and we change with them	Regularly update and optimize the educational content and methods, and introduce the latest entrepreneurial ideas and practical experience
Cooperate with industry	Entrepreneurs and investors are invited to participate in teaching and provide internship and employment opportunities
Build an entrepreneurial ecosystem	Including business incubator, entrepreneurship competition, entrepreneurship training, etc., to provide more entrepreneurship resources and support
Pay attention to cultivating students' innovative thinking and entrepreneurial spirit	Design challenging tasks and projects to develop innovative thinking and problem-solving skills

To better leverage the role of digital modularization in entrepreneurial education, enhance the quality of education and students' entrepreneurial abilities, we specifically propose the following suggestions and implementation paths:

5.1 Enrich module content

To continually improve and update the module content, ensuring it remains up-to-date, covering the latest entrepreneurial theories and practical experiences. We must dedicate ourselves to continuously enriching and refreshing the content of each module, ensuring they always stand at the forefront of the era, keeping pace with the times. This is not only about updating existing knowledge but also about delving into and refining entrepreneurial theories and practical experiences. We must ensure that each module is vibrant and innovative, able to provide users with the newest and most practical entrepreneurial ideas and strategies. We should also encourage users to actively participate, sharing their entrepreneurial insights and experiences, making the module content more diverse and meaningful. In this way, our modules can not only provide users with theoretical guidance but also become their effective assistants in practicing entrepreneurship.

Table 5-2 Module content update table

module contents	update mode	Update the target
Entrepreneurial theory and practical experience	Constantly improve and update	Keep pace with The Times and keep pace with The Times
module contents	Enrich and refresh	Stand at the forefront of The Times
Entrepreneurial theory and practical experience	Dig it out and refine it out	Full of energy and innovation
module contents	Encourage users to participate	Rich and diverse, with more practical significance
module contents	Provide theoretical guidance	Right-hand man to practice entrepreneurship



5.2 Strengthen practical elements

To increase the proportion of practical modules, focus on cultivating practical skills, and enable students to master entrepreneurial skills through practical operation. In order to effectively nurture students' entrepreneurial abilities, we must shift the focus from pure theoretical teaching to mastering practical skills. This is not merely a simple adjustment of proportions but a fundamental shift in educational philosophy. The practical component should occupy a more central position in students' overall learning experience and become a primary driving force for their growth.

By increasing the proportion of practical modules, we encourage students to apply theoretical knowledge to real-life situations, thereby deepening their understanding and application of knowledge. This practice-oriented learning approach helps develop students' problem-solving abilities, innovative thinking, and teamwork skills, all of which are essential core skills in the entrepreneurial process. Additionally, we should emphasize the systematic cultivation of practical skills. This includes designing challenging practical projects, providing ample opportunities for practice, and establishing practical platforms closely linked to the industry. Through these practical experiences, students will have the opportunity to personally experience the challenges and joys of entrepreneurship, thereby gaining a deeper understanding of the essence and requirements of entrepreneurship.

Table 5-3 Table of strengthening practice links

content	Description
Increase the practice module proportion	Pay attention to the cultivation of practical ability, so that students can master entrepreneurial skills in practical operation
Change the concept of education	From the pure theoretical teaching to the mastery of practical skills, the practical links should occupy a more core position
Practice-oriented approach to learning	Students are encouraged to apply theoretical knowledge to practical situations to develop problem solving, innovative thinking and teamwork
Systematically cultivate practical ability	Design challenging practice projects, provide sufficient opportunities to practice, and build a practice platform with the industry
The organic combination of practical operation and theoretical learning	Theory provides guidance for practice, and practice in turn verifies and enriches the theory, which helps students to build a solid bridge between theory and practice
Comprehensive and in-depth education reform	To make education more close to the reality, more in line with the needs of entrepreneurship, to provide a more comprehensive, systematic and practical entrepreneurial skills training path

We should also focus on the organic integration of practical operations and theoretical learning. Theory guides practice, while practice in turn validates and enriches theory. This bidirectional interactive teaching model will help students establish a solid bridge between theory and practice, laying a solid foundation for their future entrepreneurial path. Strengthening the



practical component not only involves adjusting the proportion of teaching content but also represents a comprehensive and in-depth educational reform. It will make our education more closely aligned with reality, better suited to the needs of entrepreneurship, and provide students with a more comprehensive, systematic, and practical path for developing entrepreneurial skills.

5.3 Personalized recommendations

By utilizing big data and artificial intelligence technologies to analyze students' learning needs and interests, recommending suitable modules for them, personalized learning can be achieved. In the modern field of education, personalized recommendations have become a revolutionary innovation. With the powerful combination of big data and artificial intelligence technologies, we can delve deep into students' learning needs and interests to provide them with highly personalized learning experiences. This recommendation system is not only based on students' historical learning data but also can real-time analyze students' learning behaviors and feedback to recommend the most suitable modules and resources for them. The application of big data technology enables educators to collect massive amounts of data on students' learning processes, including their study duration, progress, interaction frequency, and more. Additionally, the intervention of artificial intelligence technology can deeply analyze and process this data to uncover students' learning preferences, difficulties, and needs. Based on these analytical results, personalized recommendation systems can accurately recommend modules that match students' proficiency levels and interests, helping them learn more efficiently. Personalized recommendations can also dynamically adjust based on students' learning feedback. When students encounter difficulties during the learning process or exhibit special interests in certain modules, the recommendation system can promptly adjust its strategies to provide students with learning resources that better meet their needs. This dynamic adjustment process makes the learning experience more flexible and personalized, helping to stimulate students' interest and motivation to learn. Through the integration of big data and artificial intelligence technologies, personalized recommendations create a more intelligent, efficient, and engaging learning environment for students. This environment not only meets students' diverse learning needs but also inspires their learning potential and innovative spirit, laying a solid foundation for future learning and development.

Table 5-4 Personalized recommendation form

technology	Apply	Effect
big data	Analyze your learning needs and interests	Provide a personalized learning experience
artificial intelligence	Analyze learning behavior and feedback in real-time	Recommend the most appropriate modules and resources
Dynamic adjustment	Adjust the recommended strategy based on the learning feedback	Stimulate your interest and motivation in learning

5.4 Faculty training

Enhancing the training of teachers to improve their digital teaching capabilities and entrepreneurial education level is crucial to ensure the effective implementation of digital modular entrepreneurship education methods. Teacher training is a vital component in the field of education, especially in the current context of global digitization and entrepreneurial trends



sweeping across. Strengthening teacher training is not only a necessity to enhance their individual abilities but also a key factor in ensuring the successful implementation of digital modular entrepreneurship education methods. Firstly, cultivating digital teaching capabilities has become an indispensable skill for modern educators. With the rapid advancement of information technology, educational methods and tools are undergoing profound changes. Teachers need to proficiently utilize various digital teaching tools such as online teaching platforms, multimedia teaching software, etc., in order to better cater to students' learning needs and provide richer, more engaging teaching content. Secondly, elevating the level of entrepreneurial education is equally important. In today's society, entrepreneurship has become a significant career choice and development path. Teachers need to possess relevant knowledge and skills in entrepreneurial education to guide students in understanding entrepreneurship correctly, nurturing their entrepreneurial spirit and capabilities. This not only benefits students' personal development but also contributes to fostering more entrepreneurial talents in society, driving economic innovation and development.

To ensure the effective implementation of digital modular entrepreneurship education methods, it is necessary to provide systematic training for teachers. This includes developing digital teaching skills, instilling entrepreneurial education concepts, practicing modular teaching methods, and more. Through training, teachers can better understand and apply digital modular entrepreneurship education methods, integrate them into daily teaching, and offer students higher quality and more efficient entrepreneurial education. Strengthening teacher training is crucial for enhancing the effectiveness of implementing digital modular entrepreneurship education methods. This requires active participation and efforts from teachers as well as support and guidance from schools and educational authorities. Only through these measures can we cultivate more outstanding teachers with digital teaching capabilities and entrepreneurial education levels, making greater contributions to the development and progress of society.

Table 5-5 Training contents table

Training content	Training objectives
Digital teaching ability	Train teachers to master various digital teaching tools, such as online teaching platform, multimedia teaching software, etc., to meet the learning needs of students and provide richer and more vivid teaching content.
Entrepreneurship education level	Improve teachers' knowledge and skills related to entrepreneurship education, guide students to correctly understand entrepreneurship, cultivate their entrepreneurial spirit and entrepreneurial ability, and cultivate more entrepreneurial talents for the society.
Digital modular approach to entrepreneurship education	To ensure that teachers can understand and apply digital modular entrepreneurship education methods, integrate them into daily teaching, and provide students with better quality and efficient entrepreneurship education.



5.2 The impact of digital modular entrepreneurial education methods on students' entrepreneurial abilities

5.2.1 Enhancing entrepreneurial awareness

The digital module form of entrepreneurial education method, through rich course content and practical teaching elements, stimulates students' entrepreneurial interests and enthusiasm, enhances their entrepreneurial awareness. Deepening entrepreneurial awareness can drive innovation in entrepreneurial education driven by digital modules. In this era full of opportunities and challenges, the importance of entrepreneurial education is increasingly highlighted. Traditional educational methods often focus on theoretical knowledge dissemination while neglecting the cultivation of students' practical skills and innovative thinking. However, with the rapid development of digital technology, the digital module form of entrepreneurial education method has emerged, injecting new vitality into entrepreneurial education. The digital module form of entrepreneurial education method, with its unique charm and advantages, is gradually changing the landscape of traditional entrepreneurial education. It employs advanced digital technology to present course content in a modular and interactive format, allowing students to learn entrepreneurial knowledge in a relaxed and enjoyable atmosphere, stimulating their entrepreneurial interests and enthusiasm.

At the same time, through rich practical teaching elements, students can apply the knowledge they have learned to actual entrepreneurial scenarios, enhancing their practical skills and innovative thinking, laying a solid foundation for their future entrepreneurial path. The digital module form of entrepreneurial education method not only focuses on students' knowledge mastery but also emphasizes cultivating their entrepreneurial awareness and spirit. It encourages students to dare to try, dare to innovate, and face challenges and difficulties. Through continuous practice and learning, students will gradually cultivate a firm entrepreneurial belief, keen market insights, and outstanding leadership, laying a solid foundation for their future entrepreneurial path. The digital module form of entrepreneurial education method is a forward-looking and innovative educational model. Through the use of digital technology and rich practical teaching elements, it effectively enhances students' entrepreneurial awareness and practical skills, providing strong support for cultivating entrepreneurial talents in the new era. With the continuous development and improvement of this educational method, I believe that the future of entrepreneurial education will be even more exciting and enriching.

Table 5-6 Characteristics and functions of the methods of entrepreneurship education

Entrepreneurship education method	Characteristic	act on
Digital module form	The course content is modular and interactive	Stimulate students' interest and enthusiasm in entrepreneurship, and improve their entrepreneurial awareness
Practical teaching link	Rich practical teaching content	Exercise students' practical ability and innovative thinking, and lay the foundation for the road of entrepreneurship



Application of advanced technology	Adopt advanced digital technology	Inject new vitality into entrepreneurship education and change the traditional education pattern
Pay attention to student practice	Encourage students to be brave enough to try and innovate	Cultivate students' firm entrepreneurial belief, market insight and leadership
Forward-looking and innovative	Forward-looking and innovative education model	To provide strong support for the training of entrepreneurial talents in the new era

5.2.2 Cultivating entrepreneurial skills

The entrepreneurship education method in the form of digital modules focuses on cultivating practical abilities, helping students master the basic skills required for entrepreneurship through activities such as case analysis and simulated entrepreneurship. In the process of cultivating entrepreneurial skills, the use of the digital module form of entrepreneurship education method is particularly crucial. This method not only emphasizes the imparting of theoretical knowledge but also places a strong emphasis on developing practical abilities, ensuring that students can truly grasp the core skills required for entrepreneurship during their learning process. The entrepreneurship education method in the form of digital modules introduces case analysis to enable students to gain in-depth understanding of the various challenges and strategies in the entrepreneurial process. These cases often come from real entrepreneurial environments, containing rich practical experience and lessons, providing valuable references for students. Through analyzing these cases, students can learn how to identify business opportunities, develop entrepreneurial plans, organize and manage teams, raise funds, and other key skills.

Simulated entrepreneurship activities are also an important component of the digital module form of entrepreneurship education. By simulating a real entrepreneurial environment, students can participate in the entire entrepreneurial process firsthand, gaining experience in various aspects from market research, product development, marketing and promotion, to financing and collaboration. This practical learning approach not only deepens students' understanding of entrepreneurship theory but also nurtures their innovative thinking and problem-solving abilities. The entrepreneurship education method in the form of digital modules provides students with a comprehensive and systematic platform for cultivating entrepreneurial skills through activities such as case analysis and simulated entrepreneurship. This method not only helps improve students' success rate in entrepreneurship but also contributes to fostering more outstanding entrepreneurial talents for the innovation and economic growth of society.

Table 5-7 Table: Methods of entrepreneurship education

content of courses	teaching method	instructional objectives
Basic theory of entrepreneurship	Theory teaching	Master the basic concepts and theories of entrepreneurship
case analysis	case analysis	Deep understanding of entrepreneurial challenges and coping strategies



Simulation entrepreneurship	Simulation practice	Personally participate in the whole process of entrepreneurship, exercise the practical ability
Innovative thinking cultivation	Innovative thinking training	Cultivate innovative thinking and problem-solving ability
Team collaboration training	Team collaboration practice	Develop teamwork and communication skills
Financing cooperation training	Financing cooperation simulation	Cultivate the ability of financing cooperation and resource integration

5.2.3 Strengthening entrepreneurial intentions

The digital modular form of entrepreneurial education method, through personalized learning and resource sharing, reduces the threshold and risks of student entrepreneurship, enhances their entrepreneurial willingness and confidence. Stimulating entrepreneurial enthusiasm can drive the role of digital modular entrepreneurial education strategy in cultivating entrepreneurial spirit. In the wave of the digital age, traditional entrepreneurial education methods are facing a profound transformation. The digital modular form of entrepreneurial education method, in its unique way, has opened a door for students to the entrepreneurial world. This method not only lowers the threshold and risks of entrepreneurship but also invisibly enhances students' entrepreneurial willingness and confidence, thus igniting their entrepreneurial enthusiasm deep within. Personalized learning is a major highlight of this method. On the digital modular entrepreneurial education platform, each student can choose a learning path that suits them based on their interests, abilities, and needs. This personalized learning experience allows students to feel unprecedented freedom and sense of control while exploring entrepreneurial knowledge. They are no longer passive recipients but have become active learners and explorers. This role transformation not only enhances students' motivation to learn but also makes them more confident on the entrepreneurial path.

Resource sharing is another important aspect of this method. Through digital platforms, students can easily access a wealth of entrepreneurial resources, including but not limited to market analysis data, success stories, industry trends, and other information. The sharing of these resources enables students to better understand the full picture of entrepreneurship, grasp market trends, and proceed more confidently on the entrepreneurial path. At the same time, digital platforms provide a space for interactive communication among students, where they can meet like-minded partners, discuss every aspect of entrepreneurship, learn from each other, and inspire one another. The digital modular form of entrepreneurial education method, with its unique advantages of personalized learning and resource sharing, creates an entrepreneurial learning environment full of opportunities and challenges for students. In this environment, students can freely explore their entrepreneurial dreams, accumulate valuable entrepreneurial experience, and enhance their entrepreneurial willingness and confidence. The emergence of this method undoubtedly injects new vitality into nurturing the next generation of entrepreneurs and provides new possibilities for advancing entrepreneurial education.



Table 5-8 Advantages of entrepreneurship education method in digital module form

superiority	concrete content
Lower the threshold and risk of starting a business	Through personalized learning and resource sharing, to reduce the threshold and risks of students' entrepreneurship
Enhance the willingness and confidence to start businesses	Stimulating entrepreneurial enthusiasm can promote the role of digital modular entrepreneurship education strategy in cultivating entrepreneurship
Personalized learning	Each student can choose their own learning path according to their own interests, abilities and needs
resource sharing	Students can easily access rich entrepreneurial resources, including but not limited to market analysis data, success cases, industry trends and other information
interaction	Students can meet like-minded partners on the digital platform, discuss entrepreneurship together, learn from each other, and encourage each other

6. Conclusion

The digital modular form of entrepreneurship education method has significant advantages in improving educational quality and enhancing students' entrepreneurial abilities. Through personalized learning, flexible and efficient teaching methods, and practice-oriented teaching content, the digital modular form of entrepreneurship education helps cultivate students' entrepreneurial knowledge, skills, and awareness. To fully leverage its potential, it is necessary to continuously enrich module content, strengthen practical components, implement personalized recommendations, and enhance teacher training. Through these measures, we can further optimize the digital modular entrepreneurship education method to contribute to the cultivation of more talents with entrepreneurial spirit and capabilities.

Table 6-1 Summary table of the advantages and implementation strategies of digital modular entrepreneurship education methods

Superiority	implementation strategy
Improve the quality of education	Enrich module content
Enhance students' entrepreneurial ability	Strengthen practice
Personalized learning	Realize personalized recommendation
Flexible and efficient teaching methods	We will strengthen teacher training

This study on the advantages, implementation strategies, and impact on students' entrepreneurial abilities of the digital modular form of entrepreneurship education method reveals its ability to enhance students' entrepreneurial awareness, skills, and willingness, which is of significant importance for the reform and development of entrepreneurship education. In the future, we should further improve the digital modular form of entrepreneurship education method to enhance educational quality and effectiveness, thereby contributing to the cultivation of more outstanding talents with entrepreneurial spirit and capabilities.



References

- [1] Sayid Abas; Bambang Widyahseno; "MODEL PEMBERDAYAAN TKI PASCA MIGRASI MELALUI EKONOMI PRODUKTIF MENUJU KELUARGA SAKINAH", 2014.
- [2] Svetlana Kisić; Saša Petković; "Entrepreneurship Education Aimed at Developing The Skills for The Fourth Industrial Revolution", EKONOMIKA PREDUZECA, 2019.
- [3] Gündüz Güngör; "THE POWERFUL LEARNING ENVIRONMENTS IN VOCATIONAL AND TECHNICAL SECONDARY EDUCATION IN TURKEY: TEACHERS' VIEWS", EUROPEAN JOURNAL OF EDUCATION STUDIES, 2021.
- [4] Anggi Pramanda; Moh. Muchtarom; Rusnaini Rusnaini; "The Formation of New Social Capital and Civic Engagement in Society 5.0 Viewed from Digital Citizenship Education", 2021.
- [5] H. Herlina; D. Disman; S. Sapriya; N. Supriatna; "The Perceptions of Building Students Social Entrepreneurship in A Higher Education Context", PROCEEDINGS OF THE NINTH INTERNATIONAL CONFERENCE ON. 2021.
- [6] Jie Zhang; Mingming Zhang; Yaqian Liu; Ruimin Lyu; Rongrong Cui; "Research on The Integration of Media Literacy Innovative Concept and Entrepreneurship Education and Digital Dynamic Creative Expression Talents", FRONTIERS IN PSYCHOLOGY, 2021.
- [7] Biyun Chen; Xingrong Pan; "Practice and Exploration of Integrating Curriculum Ideology and Politics Into Digital Logic Circuit Course", OPEN JOURNAL OF SOCIAL SCIENCES, 2022.
- [8] Liberti Natalia Hia; "The Concept of Student Entrepreneurship in The Era of Independent Learning", INTELEKTUUM, 2022.
- [9] Ayeasha Akhter; K. M. Anwarul Islam; Md. Mobarak Karim; Wasib Bin Latif; "Examining Determinants of Digital Entrepreneurial Intention: A Case of Graduate Students", PROBLEMS AND PERSPECTIVES IN MANAGEMENT, 2022. (IF: 3)
- [10] A. Rusydiana; Nadia Nurul Izza; "Women Entrepreneurship: A Sentiment Analysis", REVIEW OF ISLAMIC SOCIAL FINANCE AND ENTREPRENEURSHIP, 2022. (IF: 3)
- [11] Mary Jesselyn Co; Bruce Craig Mitchell; "Entrepreneurship Education in South Africa: A Nationwide Survey", JOURNAL OF EDUCATION AND TRAINING, 2006. (IF: 4)
- [12] Julie McKeown; Cindy Millman; Srikanth Reddy Sursani; Kelly Smith; Lynn M. Martin; "Graduate Entrepreneurship Education in The United Kingdom", JOURNAL OF EDUCATION AND TRAINING, 2006. (IF: 3)
- [13] Luke Pittaway; Corina Edwards; "Assessment: Examining Practice in Entrepreneurship Education", JOURNAL OF EDUCATION AND TRAINING, 2012. (IF: 5)
- [14] Zahra Arasti; Mansoreh Kiani Falavarjani; Narges Imanipour; "A Study of Teaching Methods in Entrepreneurship Education for Graduate Students", HIGHER EDUCATION STUDIES, 2012. (IF: 4)
- [15] M. Lekoko; Edward M. Rankhumise; Peter J. Ras; "The Effectiveness of Entrepreneurship Education: What Matters Most?", AFRICAN JOURNAL OF BUSINESS MANAGEMENT, 2012. (IF: 3)
- [16] Michael Lorz; Susan Mueller; Thierry Volery; "ENTREPRENEURSHIP EDUCATION: A SYSTEMATIC REVIEW OF THE METHODS IN IMPACT STUDIES", JOURNAL OF ENTERPRISING CULTURE, 2013. (IF: 4)
- [17] Elaine Rideout; D. Gray; "Does Entrepreneurship Education Really Work? A Review and Methodological Critique of The Empirical Literature on The Effects of University



- Based Entrepreneurship Education", JOURNAL OF SMALL BUSINESS MANAGEMENT, 2013. (IF: 6)
- [18] Kåre Moberg; "Two Approaches to Entrepreneurship Education: The Different Effects of Education for and Through Entrepreneurship at The Lower Secondary Level", THE INTERNATIONAL JOURNAL OF MANAGEMENT EDUCATION, 2014. (IF: 3)
- [19] Katharina Fellnhofner; Sascha Kraus; "Examining Attitudes Towards Entrepreneurship Education: A Comparative Analysis Among Experts", INTERNATIONAL JOURNAL OF ENTREPRENEURIAL VENTURING, 2015. (IF: 3)
- [20] Budi Budi; Fabianus Fensi; "PENGARUH PENDIDIKAN KEWIRAUSAHAAN DALAM MENUMBUHKAN MINAT BERWIRAUSAHA", JURNAL PENGABDIAN DAN KEWIRAUSAHAAN, 2018. (IF: 3)
- [21] Sayid Abas; Bambang Widyahseno; "MODEL PEMBERDAYAAN TKI PASCA MIGRASI MELALUI EKONOMI PRODUKTIF MENUJU KELUARGA SAKINAH", 2014.
- [22] Efa Wahyu Prastyaningtyas; Zainal Arifin; "Pentingnya Pendidikan Kewirausahaan Pada Mahasiswa Dengan Memanfaatkan Teknologi Digital Sebagai Upaya Menghadapi Revolusi 4.0", PROCEEDINGS OF THE ICECRS, 2019. (IF: 3)
- [23] Svetlana Kisić; Saša Petković; "Entrepreneurship Education Aimed at Developing The Skills for The Fourth Industrial Revolution", EKONOMIKA PREDUZECA, 2019.
- [24] Manduth Ramchander; "Reconceptualising Undergraduate Entrepreneurship Education at Traditional South African Universities", ACTA COMMERCII, 2019.
- [25] H. Herlina; D. Disman; S. Sapriya; N. Supriatna; "The Perceptions of Building Students Social Entrepreneurship in A Higher Education Context", PROCEEDINGS OF THE NINTH INTERNATIONAL CONFERENCE ON. 2021.
- [26] Jie Zhang; Mingming Zhang; Yaqian Liu; Ruimin Lyu; Rongrong Cui; "Research on The Integration of Media Literacy Innovative Concept and Entrepreneurship Education and Digital Dynamic Creative Expression Talents", FRONTIERS IN PSYCHOLOGY, 2021.
- [27] Biyun Chen; Xingrong Pan; "Practice and Exploration of Integrating Curriculum Ideology and Politics Into Digital Logic Circuit Course", OPEN JOURNAL OF SOCIAL SCIENCES, 2022.
- [28] Liberti Natalia Hia; "The Concept of Student Entrepreneurship in The Era of Independent Learning", INTELEKTIUM, 2022.
- [29] Ayeasha Akhter; K. M. Anwarul Islam; Md. Mobarak Karim; Wasib Bin Latif; "Examining Determinants of Digital Entrepreneurial Intention: A Case of Graduate Students", PROBLEMS AND PERSPECTIVES IN MANAGEMENT, 2022. (IF: 3)
- [30] A. Rusydiana; Nadia Nurul Izza; "Women Entrepreneurship: A Sentiment Analysis", REVIEW OF ISLAMIC SOCIAL FINANCE AND ENTREPRENEURSHIP, 2022. (IF: 3)



055-031

EMPOWERING GLOBAL CITIZENS THROUGH SUSTAINABLE FASHION CURRICULUM: A PARADIGM SHIFT IN PEDAGOGY AND PRACTICE

Nor'Aqilah Ahmad Zabidi

Faculty of Education

The National University of Malaysia

43600 UKM Bangi, Selangor, Malaysia

Email: noraqilahahmadzabidi@gmail.com, Tel: +6017-504 7121

Khairul Azhar Jamaludin*

Faculty of Education

The National University of Malaysia

43600 UKM Bangi, Selangor, Malaysia

Email: khairuljamaludin@ukm.edu.my, Tel: +6016-555 4147

ABSTRACT

Today's fashion industry grapples with environmental and social pollution impacts, demanding an urgent educational approach to nurture a new generation of responsible global citizens. This concept paper explores the integration of a sustainable fashion curriculum as a transformative platform for its pedagogy and practices. The review of literature covers curriculum design, pedagogical methods, and the potential impact on future industry practices, positioning education as a critical driver in the shift towards a more sustainable and ethical global fashion landscape. Recent studies suggest that a paradigm shift in fashion education with a focus on incorporating ethical, environmental, and social components should be integrated into the learning process. The fashion design curriculum should take a comprehensive approach, aiming to provide students with the information and skills required by the fashion industry while instilling a sense of responsibility towards the ecosystem and community well-being. This study lays the groundwork for reframing fashion education for the future by examining existing educational frameworks and new trends in sustainable fashion. The findings are relevant to mapping the next action plans for educators, institutions, and stakeholders to work together to change the paradigm of fashion education, producing a generation of professionals and fashion consumers who are more knowledgeable.

Keywords: Sustainable Fashion Curriculum, Pedagogy, Sustainable Practices, Global Citizens.

INTRODUCTION

Today's fashion industry significantly impacts the environment and society through its production, marketing, and consumption practices. The industry's reliance on continuous consumption and global production systems leads to environmental consequences such as the depletion of natural resources, textile waste, and greenhouse gas emissions (Andriana & Islamsyah, 2023; Rashidi-Sabet & Madhavaram, 2022). The high volume of fashion product production also contributes to adverse environmental effects, including water and energy consumption, chemical use, pollution, waste production, and microplastic generation (Arias-



Meza et al., 2023). To address this challenge against the growing trend towards sustainable fashion practices, slow fashion, for example, emphasizes innovation in value propositions and customer relationships by focusing on quality, authenticity, and environmental concerns of material reuse and recycling (Liu et al., 2022; Velasco-Molpeceres et al., 2023). Furthermore, efforts are underway to regulate the fashion industry towards sustainability. Regulations promoting sustainable, fair, and circular fashion are being considered to address the negative environmental consequences of industrial production and consumption growth (Mizrachi & Tal, 2022). The scrutiny of the industry's social and environmental impact is intensifying, prompting calls for corporate sustainability and responsible fashion practices (Feng & Ngai, 2020). This demonstrates that the global community must foster the practice of sustainable fashion as a means to address the negative environmental impact.

To foster responsible global citizens, an educational approach is essential. Education plays a vital role in shaping individuals to become socially responsible and ethically aware members of society. By integrating the concept of global citizenship into the educational framework, institutions can foster a sense of civic duty and awareness of global issues among students (Van Rompay-Bartels & Tuninga, 2023). This approach aims to increase students' global perspective, intercultural understanding, and willingness to accept the responsibility of global citizenship (Shah & Brett, 2021). Higher education institutions are essential in preparing individuals to deal with global challenges and act as responsible citizens (Jakubik, 2022). By integrating sustainability principles into the curriculum, education institutions can provide students with the knowledge and skills to promote sustainable practices across various sectors, including the fashion industry (Murzyn-Kupisz & Hołuj, 2021). The global sustainability agenda is increasingly influencing higher education, emphasizing the importance of educating future leaders about sustainability and responsible practices (Kholiavko & Didenko, 2023). Thus, by fostering a holistic educational environment that includes global citizenship and sustainability principles, institutions can empower students to actively address pressing global challenges and contribute meaningfully to a more sustainable and equitable world.

The fashion industry is one of the most significant contributors to sustainable practices. By educating emerging professionals in the textile and apparel industry about sustainability, educational institutions can help shape the next generation of sustainability leaders (Jaiswal et al., 2024). Incorporating ethics and sustainability into fashion education can instil a sense of moral responsibility and environmental awareness in future industry professionals (O'Connell, 2021). However, the complexity of integrating sustainability in the fashion industry is due to retail market segments, each with specific sustainability concerns, and the creation of global fashion supply chains, making it challenging to adopt sustainable practices (Arrigo, 2021). Therefore, cultivating responsible global citizens requires an educational approach centred on global citizenship. In the fashion industry context, the importance of a sustainable fashion curriculum in addressing industry challenges cannot be disputed. Sustainable fashion education equips future professionals with the knowledge and skills to promote environmentally and socially responsible practices. By integrating sustainability principles into the fashion education curriculum, institutions can apply a deep understanding of the environmental and social impacts and allow students to recognize the challenges associated with unsustainable practices to develop innovative solutions that prioritize sustainability (Agarwal, 2021). This action must be taken seriously to enable students to support sustainable practices and responsibly address industry challenges.

The sustainable fashion curriculum also addresses the need for industry professionals to adopt sustainable practices. This focus on market demands overshadows critical aspects such as



sustainability, ethics, and social justice within fashion curricula. Additionally, the existing structure of fashion education may not fully integrate new technologies and sustainable practices to meet the evolving needs of the industry (Berk & Wallinger, 2019). These challenges underscore the importance of adopting a more comprehensive and adaptable approach to fashion education that embraces inclusivity and forward-thinking pedagogy. Furthermore, the current state of fashion education may lack emphasis on sustainability and ethical considerations in design practices (Andrés, 2024). While growing awareness of sustainable fashion exists, incorporating sustainability principles into fashion education programs remains a significant challenge (Agarwal, 2023; Wood et al., 2023). This education gap could result in fashion professionals not being adequately equipped to address environmental and social issues within the industry. To address this gap, a paradigm shift in fashion education is necessary to promote sustainability and social responsibility, providing students with the necessary knowledge and skills to navigate the complexities of the modern fashion landscape (Murzyn-Kupisz & Hołuj, 2021). Overcoming these challenges requires a thorough reassessment and redesign of fashion curricula to align with the demands of a rapidly changing industry and society. Therefore, this concept paper aims to explore integrating a sustainable fashion curriculum as a transformative platform that includes curriculum design, pedagogical methods, and potential impact on future industry practices.

LITERATURE REVIEW

Fashion Education

Fashion education encompasses a wide range of learning experiences designed to prepare individuals for careers in the fashion industry. It involves acquiring knowledge and skills related to various aspects of fashion, such as design, sustainability, entrepreneurship, and creativity (Abu Bedor et al., 2021; Ma, 2023). Fashion education is essential for shaping future industry professionals by providing them with the necessary tools to navigate the complexities of the fashion world (Afi Appiah, 2023). However, the current state of fashion education needs to be improved to keep up with the rapidly evolving industry landscape. Integrating sustainable practices, technological advancements, and changing consumer demands present significant hurdles for fashion education programs (Murzyn-Kupisz & Hołuj, 2021). There is a growing recognition of the need to reassess and adjust fashion curricula to tackle these challenges and ensure that students are well-prepared to meet the demands of a dynamic and competitive industry.

Furthermore, fashion education is increasingly urged to include sustainability, ethics, and social responsibility elements in its curriculum. The focus on sustainable fashion practices is gaining momentum, reflecting a shift towards more environmentally conscious and socially responsible approaches within the industry (D'Itria & Aus, 2023; Fletcher & Williams, 2013; Ray & Nayak, 2023). However, integrating sustainability into fashion education comes with challenges, including reorienting pedagogical approaches, developing eco-friendly materials, and instilling a mindset of innovation and creativity that aligns with sustainable principles (Agarwal, 2018; Wood et al., 2023). As the fashion industry evolves in response to global trends and consumer preferences, fashion education must adapt to ensure that future professionals are prepared to drive positive change and contribute to a more sustainable and ethical fashion landscape.

Incorporating sustainability principles into the fashion curriculum is essential to encourage a more sustainable social responsibility. Fashion education now struggles to include



sustainability elements in its courses (Murzyn-Kupisz & Hołuj, 2021). There is a lack of education for students on sustainable practices in the fashion sector, which is essential for resolving environmental and social issues in the business despite its increasing significance. Furthermore, the insufficient focus on ethical considerations and social responsibility in fashion education presents additional obstacles (Pérez et al., 2022). Despite growing interest in ethical fashion and ecological practices, ethical fashion education is still a niche trend because of limited consumer awareness and purchasing patterns (Lusty & Richards, 2024). It is essential for fashion education programmes to incorporate ethical concepts and social consciousness into their curricula to encourage a more responsible and sustainable fashion industry. To overcome these restrictions, fashion education must adopt a comprehensive strategy that includes sustainability, ethics, and social responsibility to equip students adequately for the modern fashion industry.

Sustainable Fashion Curriculum

Sustainable fashion education is currently receiving increasing attention. Sustainable fashion education emphasizes production, business considerations, consumer behaviour, and attitudes about adopting sustainable fashion (Henninger et al., 2016; Junstrand et al., 2024). Sustainable fashion education focuses on integrating sustainability ideas into the curriculum to tackle environmental and social concerns in the fashion industry (Grundmeier et al., 2023). High-street fashion companies are incorporating sustainable fashion practices by offering organic and fair trade products, along with the industry's move towards sustainability (Hur & Cassidy, 2019). Sustainable fashion education promotes behaviours like reducing, reusing, and recycling and innovative techniques like the mulage process (Pavlova & Inanova, 2023). This strategy tries to mitigate the negative impacts of human activities on the environment by decreasing water and energy usage, promoting recycling, and enhancing social welfare (Pavlova & Inanova, 2023). Fashion education has introduced several strategies that allow educators to be more imaginative and inventive in promoting a sustainable environment.

The implementation of sustainability integration in the curriculum requires a comprehensive change. Sustainability is incorporated into the fashion curriculum through deliberate sustainable innovation. Educators can utilize technical advancements, alterations in business models, operational techniques, and procedures to enhance sustainability in the fashion industry (Azman et al., 2022). It is recommended that sustainability be incorporated into the fashion education curriculum rather than being a standalone course, emphasizing incorporating sustainable concepts throughout the educational programme (Agarwal, 2023). This integration can enhance students' comprehension of the challenges and opportunities of sustainable design, equipping them with crucial knowledge and skills to implement sustainable fashion practices (Murzyn-Kupisz & Hołuj, 2021). For example, by incorporating zero-waste design into existing fashion courses, students may acquire the necessary skills to create apparel with minimum waste, aligning with sustainable fashion concepts (Gam & Banning, 2020).

A conceptual approach focusing on skill development can enhance the execution of a sustainable fashion curriculum, leading to tremendous success in sustainability (Abu Bedor et al., 2021). Implementing successful communication and educational programmes can facilitate the integration of sustainability concepts into fashion education, promoting the use of innovative materials and eco-friendly methods by both students and educators (Wood et al., 2023). Implementing a sustainable fashion curriculum necessitates a thorough and integrated strategy. The strategy should integrate sustainability ideas into the educational experience to prepare students to make a positive impact on a more ecologically aware and socially



responsible fashion sector.

Pedagogical Methods and Practices in Sustainable Fashion Education

Teachers play an essential role in implementing sustainable fashion education. Effective pedagogical techniques and practices in sustainable fashion education are essential for providing students with the knowledge and skills needed to negotiate the complexities of the fashion industry and promote sustainability. Previous research has identified many instructional approaches and practices in sustainable fashion education. Implementing the zero-waste pedagogical approach in fashion design education is a method to include sustainability in teaching practices (Agarwal, 2023; Gam & Banning, 2020; Jestratijevic & Hillery, 2023). Murzyn-Kupisz and Holuj (2021) emphasize enhancing teachers' pedagogical skills to incorporate fashion sustainability education by integrating craftsmanship, artistic abilities, and commercial skills. Gam and Banning (2020) demonstrate the actual implementation of sustainable principles by emphasizing the importance of teachers in educating on sustainable fashion production abilities. Experiential learning approaches can be used to create sustainable textiles for fashion design courses, providing students with hands-on experiences that support sustainability (Wood et al, 2023). Teachers must possess the ability to select suitable teaching techniques and a strong foundation in integrating sustainable fashion into their pedagogy.

In addition to their pedagogical expertise, educators must incorporate sustainable practices into their teaching. A variety of pedagogical strategies that encourage problem-solving abilities, creative thinking, and active learning are used by teachers when integrating sustainability into their lessons (Abner et al., 2019). For instance, the curriculum incorporates sustainable fashion via an immersive learning approach (Wood et al., 2023). Teachers stressed that practical participation, effective communication, and curriculum integration are essential to promote sustainability in fashion education. Additionally, by using a student-centred pedagogical approach, educators can help students develop critical thinking abilities (Choi, 2019), problem-solving skills in the context of sustainable fashion (Choi, 2019; Gam & Banning, 2020), technical skills related to sustainable practices (Ma, 2023), and digital technology skills (Choi, 2019). Teachers who integrate sustainable fashion can give students various knowledge and skills related to sustainability. These practices aim to equip students with the necessary skills and knowledge to navigate the evolving landscape of fashion design while considering environmental, social, and cultural aspects.

Potential Impact of Sustainable Fashion Education on Industry Practices

The impact of sustainable fashion education on industry practices is substantial and varied. By incorporating sustainability principles into fashion education curricula, future professionals have the knowledge and skills to drive positive change within the industry (Jaiswal et al., 2024). This integration can lead to a shift towards more sustainable business models in the fashion industry, with an increasing adoption of corporate social responsibility practices (Mandarić et al., 2022). Educating emerging textile and apparel professionals on sustainability principles can influence practices across the fashion life cycle, from product conception to disposal, promoting environmentally conscious decisions (Jaiswal et al., 2024). Furthermore, sustainable fashion education can influence consumer behaviour and industry practices by promoting sustainable apparel consumption (Gupta et al., 2019). By emphasizing style and quality over quantity, sustainable fashion education can encourage consumers to make more conscious purchasing decisions, reducing overconsumption and shifting towards slow fashion practices (Gupta et al., 2019). Additionally, sustainable retailing practices in the fashion industry, such



as green branding and eco-labelling, can be further promoted through education, fostering a more sustainable approach to fashion retail (Agarwal, 2020). Overall, sustainable fashion education has the potential to drive transformative change within the industry, promoting ethical and environmentally responsible practices that benefit both the planet and society.

Sustainable fashion education can significantly impact industry practices by fostering a shift towards environmentally conscious approaches (Agarwal, 2023; Wood et al, 2023). By integrating sustainable design concepts, materials, and production processes into the fashion curriculum, future professionals can contribute positively to the environment. This education can lead to developing and adopting eco-friendly materials, such as bacterial cellulose, and innovative practices that reduce carbon footprint and textile waste (Wood et al., 2023). Furthermore, educating consumers about the true nature of the fashion industry and its environmental impacts can drive more mindful purchasing decisions, influencing companies to improve their corporate responsibility and overall environmental sustainability. Ultimately, sustainable fashion education plays a crucial role in shaping a more sustainable and responsible fashion industry for the future.

STRATEGIES FOR INTEGRATING SUSTAINABLE FASHION PRINCIPLES

Integration of ethical, environmental, and social components into curriculum design

In fashion education, integrating ethical, environmental, and social components into curriculum design is an important endeavour geared towards equipping students with the necessary tools to address sustainability challenges in the industry. Various studies underline the importance of applying sustainability principles to fashion education, emphasizing its alignment with global initiatives such as the Principles of Responsible Management Education (Muhammad & Dabbagh, 2021). For example, Radclyffe-Thomas (2018) highlights the profound impact of clothing design on sustainability, supporting its priority in curriculum design. Jaiswal et al. (2024) support promoting sustainability-based education in fashion design programs to increase students' competence in sustainable development. Collectively, this study underscores the importance of integrating sustainability, ethical considerations, and social responsibility into the fashion education curriculum to foster a cohort of professionals capable of contributing to a more sustainable and ethical fashion industry.

To achieve this integration, educators can utilize a variety of pedagogical approaches and teaching practices. By embedding sustainability principles into the curriculum, educators can better understand ethical and environmental considerations in the fashion industry (Lozano et al., 2019). Collaborative efforts between educational institutions and industry partners offer real-world insights that enrich students' learning experiences and prepare them for sustainable industry standards (Bui et al., 2023; Shephard & Pookulangara, 2022). In addition, emphasizing competencies related to ethics, environmental awareness, and social responsibility helps foster a comprehensive understanding of sustainable fashion practices (Azman et al., 2022). Furthermore, innovative pedagogical methods such as project-based learning and experiential activities can effectively engage students in critical reflection on ethical and environmental issues in fashion design (Gam & Banning, 2020). By bridging theory and practice in teacher education, educators can effectively bridge the gap between theoretical knowledge and practical application, fostering a cohesive approach to integrating ethical, environmental, and social components into the fashion curriculum. Ultimately, the promotion of sustainability competencies and ethical considerations in fashion design education has the potential to



catalyze a paradigm shift towards more responsible and environmentally conscious industrial practices. Therefore, by integrating ethical, environmental, and social components into curriculum design, fashion education emerges as an essential agent in shaping a more sustainable and socially responsible fashion industry.

Comprehensive approach to providing knowledge and skills for the fashion industry

In ensuring individuals' preparedness for the fashion industry, it is imperative to embed social, economic, and environmental dimensions within fashion education. This comprehensive approach is instrumental in addressing sustainability challenges and fostering constructive contributions to the industry. Franco et al. (2018) underscore the significance of a strategic and coordinated higher education approach for sustainable development, which is crucial for effectively addressing social and environmental sustainability issues. Similarly, Jaiswal et al. (2024) stress the necessity of crafting a holistic fashion curriculum integrating social, economic, and environmental functions to arm professionals with sustainability competencies in the textile and apparel realm. Moreover, incorporating economic dimensions into fashion education is crucial for fostering financial sustainability within the industry (Rodrigues Da Rocha et al., 2024). By providing students with a solid foundation in economic theory and business management, fashion education can empower them to make informed decisions that drive profitability while considering the long-term impact on stakeholders and the environment.

Furthermore, integrating participatory action research and interdisciplinary opportunities in fashion education, as proposed by Lam et al. (2022), can bolster students' conceptual skills and design processes, aligning with the industry's evolving demands. Additionally, instilling a sustainable mindset, ethical understanding, and practical skills, as Binde and Freimane (2022) advocate, fosters responsible and sustainable fashion practices among budding designers. As highlighted by Shephard and Pookulangara (2022), educational institutions play a pivotal role in supporting the industry's transformation and enhancing students' grasp of textiles and fashion by weaving in knowledge transfer programs and inquiry-based learning methodologies. These approaches foster skill development and nurture critical thinking and active engagement in the learning journey. Therefore, a comprehensive approach to furnishing knowledge and skills for the fashion industry entails the integration of sustainability principles, interdisciplinary opportunities, practical skill development, and innovative teaching methodologies.

Fostering a sense of responsibility towards ecosystems and community well-being

In nurturing a commitment to ecosystems and community welfare within the fashion realm, infusing ethical and sustainable practices into fashion education is vital. By embedding sustainability, social responsibility, and environmental consciousness principles into the curriculum, individuals can cultivate a deeper awareness of their impact on ecosystems and communities. This approach resonates with the recognition that fashion designers wield significant influence in driving positive change across the industry's economic, environmental, social, and cultural dimensions (Murzyn-Kupisz & Hołuj, 2021). Educational endeavours focused on sustainable and material innovation in fashion serve as pivotal platforms for students to grasp the imperative of integrating economic, ecological, and social considerations into their design processes (Azman et al., 2022; Wood et al, 2023). Through a pedagogical emphasis on experiential learning and interdisciplinary approaches, students can acquire practical competencies and knowledge to address environmental and social impacts within the fashion landscape (Wood et al, 2023). Moreover, online education platforms have become a



potent tool for disseminating corporate sustainability knowledge and advancing sustainable practices within the fast fashion sector (Pedersen et al., 2022).

Studies on consumer behaviour underscore a burgeoning interest in sustainability, signalling a shift towards ethical consumption patterns and a burgeoning market for sustainable fashion products (Nautiyal & Atre, 2022). By educating consumers about the ramifications of their fashion choices and leveraging effective communication strategies to promote sustainable terminology, fashion marketers can bolster consumer awareness and propel sustainable fashion practices (Ritch, 2022). In conclusion, fostering a sense of responsibility towards ecosystems and community well-being in the fashion industry necessitates a multifaceted approach integrating sustainability principles, ethical considerations, and innovative educational strategies. The fashion industry can strive towards a more responsible and environmentally conscious future by empowering individuals with the knowledge and skills to make informed decisions and adopt sustainable practices.

CASE STUDY AND BEST PRACTICES

Examination of existing sustainable fashion education programs

To explore existing sustainable fashion education programs, it is crucial to consider various studies illuminating the integration of sustainability principles into fashion curricula. Purnama et al. (2022) highlight the importance of explicitly incorporating sustainability attitudes into sustainable fashion design curricula, emphasizing the significance of integrating sustainability as a fundamental aspect of the educational framework. Additionally, Franco et al. (2019) discuss the strategic integration of higher education for sustainable development into policy, curriculum, and practice, aligning with global sustainability goals. This underscores educational institutions' need to adopt a holistic approach to sustainability education that encompasses policy, curriculum design, and practical implementation. Azman et al. (2022) delve into the significance of sustainable practices in pattern-making within fashion institutions, emphasizing the pedagogical importance of sustainability in fashion education. This study underscores the need for practical and hands-on approaches to sustainability within the fashion curriculum.

Moreover, D'Itria & Vacca (2021) focus on the transformative challenge of integrating sustainable development issues into fashion design education, aiming to support the transition to a new positive model. This highlights the transformative potential of sustainable fashion education in shaping the industry's future. Ma's study (2022) proposes a model for sustainable education in fashion design through the development, implementation, and evaluation of a specific curriculum, which uses a challenge-based learning approach to facilitate the learning of concepts involving sustainability and sustainable fashion. Wood et al. (2023) investigated a pedagogical approach to developing sustainable textiles for a fashion design curriculum. They found that with appropriate communication and educational strategies, the principles of sustainability in fashion and the acceptability of novel materials can be elicited in different audiences. These studies underscore the importance of integrating sustainability attitudes, practices, and principles into fashion education programs to equip students with the knowledge, skills, and mindset necessary to contribute to a more sustainable and responsible fashion industry.



Analysis of successful implementation strategies

To empower global citizens through a sustainable fashion curriculum, successful implementation strategies can draw from various educational fields. Qu et al. (2020) present a case of successful implementation of sustainability strategies in higher education, emphasizing the importance of promoting sustainability through curriculum development. This underscores the pivotal role of educational institutions in fostering sustainable practices among future professionals in the fashion industry. Moreover, Junstrand et al. (2024) advocate for a transformative approach to education for sustainable development, emphasizing the need to instigate paradigm shifts in thinking and behaviour. Such transformative education aims to impart knowledge, cultivate critical thinking, and empower individuals to become agents of change in their communities.

Furthermore, Franco et al. (2019) provide valuable insights into integrating sustainability into higher education policy and practice. They highlight the imperative of aligning educational initiatives with the Sustainable Development Goals (SDGs), emphasizing the role of academia in addressing global sustainability challenges. This underscores the importance of incorporating sustainability principles into curriculum content and institutional policies and practices. Abu Bedor et al. (2021) also advocate for a collaborative approach involving government, industry, and educational sectors to achieve the SDGs. This collaborative effort recognizes the interconnectedness of various stakeholders in driving sustainable development and emphasizes the importance of partnerships in implementing effective educational interventions.

Moreover, Choi (2019) proposes problem-based learning as a pedagogical strategy to address sustainability challenges in fashion education. Problem-based learning engages students in real-world scenarios, fostering critical thinking and problem-solving skills. By integrating sustainability challenges into the curriculum, students are encouraged to explore innovative solutions and develop a deeper understanding of sustainability issues within the fashion industry. Additionally, Purnama et al. (2022) stress the importance of implementing a sustainable fashion design curriculum to raise awareness among stakeholders about environmental preservation. This highlights the role of education in shaping future professionals and promoting consumer awareness and responsible consumption practices. Overall, by incorporating elements from successful sustainability implementation strategies in higher education, transformative teaching approaches, and problem-based learning methodologies, global citizens can be empowered through a sustainable fashion curriculum.

Lessons learned and key takeaways for educators and institutions.

Empowering global citizens through a sustainable fashion curriculum requires a multifaceted approach that integrates interdisciplinary perspectives, practical application, ethical and social considerations, industry engagement, a global perspective, and the promotion of lifelong learning. By integrating these elements into sustainable fashion education, educators and institutions can prepare students to navigate the complexities of the fashion industry while fostering a commitment to sustainability and responsible citizenship on a global scale. The description of each element for integration into the fashion curriculum is as follows:

i. Interdisciplinary Approaches

One critical lesson learned is the importance of incorporating interdisciplinary perspectives into a sustainable fashion curriculum. Educators can provide students with a comprehensive



understanding of sustainability issues in the fashion industry by integrating knowledge from diverse fields such as environmental science, economics, sociology, and ethics (Agarwal, 2023; Murzyn-Kupisz & Holuj, 2021). Interdisciplinary approaches enrich students' learning experiences and enable them to grasp the interconnectedness of environmental, social, and economic dimensions of sustainability.

ii. Practical Application

Another key takeaway is the significance of practical application within the curriculum. Hands-on learning experiences, such as real-world projects, internships, or industry collaborations, allow students to apply theoretical knowledge to address real-life sustainability challenges in the fashion industry (Agarwal, 2021; Choi, 2019). Students develop critical thinking skills, problem-solving abilities, and a deeper appreciation for sustainable practices and their impact by engaging in practical activities.

iii. Ethical and Social Considerations

Ethical and social considerations are also integral components of a sustainable fashion curriculum. Educators should encourage students to critically examine the social implications of fashion production, consumption, and labour practices, fostering a sense of responsibility toward workers' rights, diversity, equity, and inclusion (Romero et al., 2022). By addressing ethical and social issues alongside environmental concerns, educators empower students to become advocates for social justice and ethical fashion practices.

iv. Industry Engagement

Industry engagement is essential for providing students insights into industry practices and trends. Collaborations with fashion brands, manufacturers, and sustainability organizations offer students opportunities to gain firsthand experience in the field and understand the challenges and opportunities associated with sustainable fashion (Ma, 2022). Industry partnerships also facilitate knowledge exchange and bridge the gap between academia and practice (Bui et al., 2023; Gam & Banning, 2020; Wood et al., 2023).

v. Global Perspective

A global perspective is indispensable in preparing students to navigate the globalized nature of the fashion industry. Educators should expose students to diverse cultural perspectives, global supply chain dynamics, and international sustainability initiatives (Schmitz et al., 2024). By fostering a global mindset, educators empower students to understand the interconnectedness of global sustainability issues and contribute to positive change on a global scale.

vi. Lifelong Learning

Promoting lifelong learning is essential for ensuring students remain informed and engaged in sustainability issues throughout their careers (Blaga et al., 2021). Encouraging students to stay updated on current research, trends, and best practices sustainably equips them with the skills and knowledge to adapt to evolving industry landscapes and drive continuous improvement in sustainable fashion practices.

FUTURE DIRECTIONS AND RECOMMENDATIONS

The integration of sustainable fashion education requires concerted efforts among various stakeholders, including educators, educational institutions, industry players, policymakers, and community organizations. Educators can collaborate with industry professionals to develop



curricula informed by real-world challenges and best practices (Bui et al., 2023). By cultivating partnerships with fashion companies, educators can provide students with hands-on learning experiences, such as internships, workshops, and collaborative projects. Additionally, partnerships with community organizations can facilitate experiential learning opportunities that involve students in local sustainability initiatives and social impact projects (Jestratijevic & Hillery, 2023).

Educational institutions are essential in providing resources and support for sustainable fashion education initiatives. By allocating research and curriculum development funding, institutions can foster innovation in sustainable fashion education and provide students access to cutting-edge resources and facilities (Abner & Baytar, 2019). In addition, institutions can create interdisciplinary collaboration between departments such as fashion design, environmental science, business, and social science to promote a holistic and interdisciplinary approach to sustainable fashion education (Ma, 2022; Wood et al., 2023). Thus, through this collaborative relationship, stakeholders can leverage their expertise and resources to develop innovative curricula, research initiatives, and industry partnerships that empower students to be catalysts for sustainability in the fashion industry.

Furthermore, ongoing research and innovation are essential for advancing sustainable fashion education and addressing the industry's complex challenges (De Ponte et al., 2023). Research plays a crucial role in generating new knowledge, identifying best practices, and evaluating the effectiveness of educational interventions in promoting sustainability. By conducting research, educators and researchers can gain insight into the most effective strategies for integrating sustainability into fashion education and fostering sustainable mindsets and behaviours among students (Joshua Alahira et al., 2024). Innovation is also essential to drive progress in sustainable fashion education. Innovations in teaching methods, learning technologies, and educational resources can increase the effectiveness and accessibility of sustainable fashion education initiatives (Hur & Beverley, 2023). For example, digital tools, such as virtual reality simulations and online platforms, can provide students with an immersive learning experience and allow them to explore complex sustainability concepts engagingly and interactively ((Abner & Baytar, 2019). In short, continued research and innovation are essential to advance sustainable fashion education and drive meaningful change in the industry.

Furthermore, stakeholders must support policies and regulations that promote sustainability and ethical practices in the fashion industry. Interact with policymakers, advocacy groups, and other stakeholders to raise awareness of the environmental and social impacts of the fashion industry and advocate for policy changes that support sustainable fashion education and practice (Singh & Bansal, 2024). By implementing this action plan, educators, institutions, and stakeholders can work together to drive a paradigm shift in fashion education toward sustainability. By fostering collaboration, innovation, and advocacy, they can empower the next generation of fashion professionals and consumers to create a more sustainable and equitable future for the industry.

CONCLUSION

In conclusion, the integration of a sustainable fashion curriculum represents a pivotal shift in fashion education towards nurturing responsible global citizens equipped to address the industry's environmental and social challenges. Educators can instill ethical responsibility and environmental consciousness in future fashion professionals and consumers by reimagining



curriculum design, pedagogical methods, and industry practices. The imperative to incorporate sustainability principles into fashion education is underscored by the pressing need to mitigate the environmental and social impacts of the fashion industry. Students can be empowered to make informed decisions prioritizing sustainability and community well-being through a comprehensive approach encompassing ethical, environmental, and social considerations. Furthermore, by reframing fashion education to include sustainable practices, educators and institutions play a crucial role in shaping a more sustainable and ethical global fashion landscape. This paradigm shift equips students with the knowledge and skills needed for the industry and fosters a sense of responsibility towards the ecosystem and society.

Moving forward, collaborative efforts among stakeholders in academia, industry, and government are essential to drive sustainable development goals and promote responsible consumption practices within the fashion industry. By embracing a transformative approach to education for sustainable development, educators can empower individuals to become agents of change and contribute to a more sustainable and equitable future for the fashion industry. Implementing a sustainable fashion curriculum catalyzes positive change, paving the way for a generation of professionals and consumers who are knowledgeable and committed to creating a more sustainable and responsible fashion industry. These findings provide a roadmap for educators, institutions, and stakeholders to collaborate for a paradigm shift in fashion education, shaping the future of a generation of professionals and fashion consumers who are more knowledgeable and ethically responsible.

REFERENCES

- Abner, M., & Baytar, F. (2019). Apps to increase student engagement: a case of textiles and apparel sustainability education. *International Journal of Fashion Design, Technology and Education*, 12(1), 56–64. <https://doi.org/10.1080/17543266.2018.1477996>
- Abner, M., Baytar, F., & Kreiner, D. (2019). Applying the ESD approach in textile and apparel education. *International Journal of Sustainability in Higher Education*, 20(1), 75–90. <https://doi.org/10.1108/IJSHE-02-2018-0029>
- Abu Bedor, S., Kamis, A., Shafie, S., Farah Najwa, A. P., Jamaluddin, R., & Rahim, M. B. (2021). Issues and Trends in Fashion Education Sustainability. *Asian Journal of Vocational Education and Humanities*, 2(1), 9–18. <https://doi.org/10.53797/ajvah.v2i1.2.2021>
- Afi Appiah, N. (2023). Higher Fashion Education in Perspective: The Effects of Work-Based Learning On Industry Requirements. *British Journal of Multidisciplinary and Advanced Studies: Education, Learning, Training & Development*, 4(3), 137–150. <https://doi.org/10.37745/bjmas.2022.00209>
- Agarwal, S. (2021). Integration of Sustainable Practices in Fashion Design Education: An Experimental Study Based on Experiential Learning. *The International Journal of Design Education*, 15(2), 153–166. <https://doi.org/10.18848/2325128X/CGP/v15i02/153-166>
- Agarwal, V. (2018). Sustainable fashion education in changing world scenario. *European Journal of Sustainable Development*, 7(1). <https://doi.org/10.14207/ejsd.2018.v7n1p365>
- Agarwal, V. (2023). Sustainable Fashion Education: Future Design and Pedagogy. *RESEARCH REVIEW International Journal of Multidisciplinary*, 8(4), 29–40. <https://doi.org/10.31305/rrijm.2023.v08.n04.004>
- Andrés, A. (2024). Role of Sustainability and Ethics in Fashion Design and Production in South



- America. *International Journal of Fashion and Design*, 3(1), 12–23.
<https://doi.org/10.47604/ijfd.2388>
- Andriana, Y. F., & Islamsyah, H. (2023). Designing Fashion Product with Natural Material and Purple Sweet Potato Peel Dye. *Jurnal Desain*, 10(2), 376.
<https://doi.org/10.30998/jd.v10i2.13075>
- Arias-Meza, M., Alvarez-Risco, A., Cuya-Velásquez, B. B., Gómez-Prado, R., de las Mercedes Anderson-Seminario, M., & Del-Aguila-Arcentales, S. (2023). Theory of Sustainable Paths for Entrepreneurship Associated with Fashion and Practical Examples (pp. 89–116). https://doi.org/10.1007/978-981-19-8895-0_4
- Arrigo, E. (2021). Collaborative consumption in the fashion industry: A systematic literature review and conceptual framework. In *Journal of Cleaner Production* (Vol. 325). Elsevier Ltd. <https://doi.org/10.1016/j.jclepro.2021.129261>
- Berk, G., & Wallinger, A. (2019, July 9). Learning Fashion Outside Academia: From Sewing Circles to Maker Spaces. *Insider Knowledge - Proceedings of the Design Research Society Learn X Design Conference*, 2019.
<https://doi.org/10.21606/learnxdesign.2019.01069>
- Binde, M., & Freimane, A. (2022). Is there a zero waste in a fashion design? 1–6.
- Blaga, M., Hofer, D., Grundmeier, A., Koksál, D., Strahle, J., Kazlacheva, Z., & Zlatev, Z. (2021). E-learning as a tool for implementing a sustainable fashion curriculum in textile universities in Europe. 98–104. <https://doi.org/10.12753/2066-026X-21-153>
- Bui, T., Cappellieri, A., & Takacs, B. (2023). The effectiveness of design practice for achieving sustainability and diffusing sustainable fashion. *International Journal of Fashion Design, Technology and Education*. <https://doi.org/10.1080/17543266.2023.2250814>
- Choi, K. H. (2019). Eco-tech fashion project: collaborative design process using problem-based learning. *International Journal of Fashion Design, Technology and Education*, 12(1), 105–117. <https://doi.org/10.1080/17543266.2018.1516808>
- D'Itria, E., & Aus, R. (2023). Circular fashion: evolving practices in a changing industry. *Sustainability: Science, Practice, and Policy*, 19(1).
<https://doi.org/10.1080/15487733.2023.2220592>
- De Ponte, C., Liscio, M. C., & Sospiro, P. (2023). State of the art on the Nexus between sustainability, fashion industry and sustainable business model. *Sustainable Chemistry and Pharmacy*, 32. <https://doi.org/10.1016/j.scp.2023.100968>
- Feng, P., & Ngai, C. S. bik. (2020). Doing more on the corporate sustainability front: A longitudinal analysis of csr reporting of global fashion companies. *Sustainability (Switzerland)*, 12(6). <https://doi.org/10.3390/su12062477>
- Fletcher, K., & Williams, D. (2013). Fashion Education in Sustainability in Practice. *Research Journal of Textile and Apparel*, 17(2), 81–88. <https://doi.org/10.1108/RJTA-17-02-2013-B011>
- Franco, I., Saito, O., Vaughter, P., Whereat, J., Kanie, N., & Takemoto, K. (2019). Higher education for sustainable development: actioning the global goals in policy, curriculum and practice. *Sustainability Science*, 14(6), 1621–1642.
<https://doi.org/10.1007/s11625-018-0628-4>
- Gam, H. J., & Banning, J. (2020). Teaching Sustainability in Fashion Design Courses Through a Zero-Waste Design Project. *Clothing and Textiles Research Journal*, 38(3), 151–165.
<https://doi.org/10.1177/0887302X20906470>
- Grundmeier, A. M., Höfer, D., Kazlacheva, Z., Zlatev, Z., Blaga, M., Koksál, D., & Strähle, J. (2023). On the importance of fashion design within a sustainable fashion curriculum at Textile Universities in Europe - Preliminary results of the European research project fashion DIET. *AIP Conference Proceedings*, 2889(1).
<https://doi.org/10.1063/5.0172783>



- Gupta, S., Gwozdz, W., & Gentry, J. (2019). The Role of Style Versus Fashion Orientation on Sustainable Apparel Consumption. *Journal of Macromarketing*, 39(2), 188–207. <https://doi.org/10.1177/0276146719835283>
- Henninger, C. E., Alevizou, P. J., & Oates, C. J. (2016). What is sustainable fashion? *Journal of Fashion Marketing and Management*, 20(4), 400–416. <https://doi.org/10.1108/JFMM-07-2015-0052>
- Hur, E., & Beverley, K. (2023). Fostering Sustainable Fashion Innovation: Insights from Ideation Tool Development and Co-Creation Workshops. *Sustainability*, 15(21), 15499. <https://doi.org/10.3390/su152115499>
- Hur, E., & Cassidy, T. (2019). Perceptions and attitudes towards sustainable fashion design: challenges and opportunities for implementing sustainability in fashion. *International Journal of Fashion Design, Technology and Education*, 12(2), 208–217. <https://doi.org/10.1080/17543266.2019.1572789>
- Jaiswal, G., Hopfer, E. N., & Dixon, D. L. (2024). Sowing the seeds of change: educating emerging textile and apparel professionals on sustainability from cotton industry perspective. *International Journal of Sustainability in Higher Education*, 25(3), 649–668. <https://doi.org/10.1108/IJSHE-08-2022-0282>
- Jakubik, M. (2022). Role of Higher Education in Solving Global Problems. *International Journal of Management, Knowledge and Learning*, 11. <https://doi.org/10.53615/22325697.11.285-295>
- Jestratić, I., & Hillery, J. L. (2023). Measuring the “Clothing Mountain”: Action Research and Sustainability Pedagogy to Reframe (Un)Sustainable Clothing Consumption in the Classroom. *Clothing and Textiles Research Journal*, 41(1), 10–25. <https://doi.org/10.1177/0887302X221084375>
- Joshua Alahira, Zamathula Queen Sikhakhane Nwokediegwu, Alexander Obaigbena, Ejike David Ugwuanyi, & Obinna Donald Daraojimba. (2024). Integrating sustainability into graphic and industrial design education: A fine arts perspective. *International Journal of Science and Research Archive*, 11(1), 2206–2213. <https://doi.org/10.30574/ijrsra.2024.11.1.0306>
- Junstrand, L., Alexander, B., & Sheldon, F. (2024). Towards Transformative Sustainable Fashion Education: The Fashion Business School’s Approach. In *Fashion for the Common Good* (pp. 208–231). Springer Nature Switzerland. https://doi.org/10.1007/978-3-031-50252-1_12
- Jyoti Singh, & Shefali Bansal. (2024). The impact of the fashion industry on the climate and ecology. *World Journal of Advanced Research and Reviews*, 21(1), 210–215. <https://doi.org/10.30574/wjarr.2024.21.1.2610>
- Kholiavko, N., & Didenko, I. (2023). World experience of University Sustainable Development. *Economics & Education*, 8(1), 89–104. <https://doi.org/10.30525/2500946x/2023-1-12>
- Lam, M. M.-L., Li, E. P. H., Liu, W.-S., & Yee-Nee Lam, E. (2022). Introducing participatory action research to vocational fashion education: theories, practices, and implications. *Journal of Vocational Education & Training*, 74(3), 415–433. <https://doi.org/10.1080/13636820.2020.1765844>
- Liu, A., Baines, E., & Ku, L. (2022). Slow Fashion Is Positively Linked to Consumers’ Well Being: Evidence from an Online Questionnaire Study in China. *Sustainability (Switzerland)*, 14(21). <https://doi.org/10.3390/su142113990>
- Lozano, R., Barreiro-Gen, M., Lozano, F., & Sammalisto, K. (2019). Teaching Sustainability in European Higher Education Institutions: Assessing the Connections between Competences and Pedagogical Approaches. *Sustainability*, 11(6), 1602. <https://doi.org/10.3390/su11061602>



- Lusty, N., & Richards, H. (2024). Modern slavery legislation and the limits of ethical fashion. *Cultural Studies*, 38(2), 322–347. <https://doi.org/10.1080/09502386.2022.2103165>
- Ma, J. J. (2023). Development of education for sustainable fashion design using a challenge based learning approach. *International Journal of Fashion Design, Technology and Education*, 16(2), 164–174. <https://doi.org/10.1080/17543266.2022.2137249>
- Mandarić, D., Hunjet, A., & Vuković, D. (2022). The Impact of Fashion Brand Sustainability on Consumer Purchasing Decisions. *Journal of Risk and Financial Management*, 15(4). <https://doi.org/10.3390/jrfm15040176>
- Maryam Syed Azman, S., Arsat, M., Mohd Amin, N. F., Suhairom, N., Husna Abdul Wahid, N., Khamis, N., Hanri, C., & Abdul Latif, A. (2022). Sustainable Practices in Pattern Making at Local Fashion Institutions: A Qualitative Study. *KnE Social Sciences*. <https://doi.org/10.18502/kss.v7i19.12490>
- Mizrachi, M. P., & Tal, A. (2022). Regulation for Promoting Sustainable, Fair and Circular Fashion. *Sustainability (Switzerland)*, 14(1). <https://doi.org/10.3390/su14010502>
- Muhammad, N. I., & Dabbagh, M. A. Al. (2021). The Effectiveness of Incorporating Technology in the Classroom as an Attractive Tool to Teach the Clothing and Textile Curriculum and the Concept of Sustainability. *Open Journal of Social Sciences*, 09(02), 279–292. <https://doi.org/10.4236/jss.2021.92019>
- Murzyn-Kupisz, M., & Hołuj, D. (2021). Fashion design education and sustainability: Towards an equilibrium between craftsmanship and artistic and business skills? *Education Sciences*, 11(9). <https://doi.org/10.3390/educsci11090531>
- O'Connell, Mark (2021). Moral fibre: integrating ethics and sustainability into fashion curriculum. Toronto Metropolitan University. Thesis. <https://doi.org/10.32920/ryerson.14657187.v1>
- Pavlova, M., & Ivanova, I. (2023). Sustainable fashion with elements of the Bulgarian national garb-reducing, reusing and recycling through mulage method. *IOP Conference Series: Earth and Environmental Science*, 1234(1). <https://doi.org/10.1088/1755-1315/1234/1/012019>
- Pedersen, E. R. G., Andersen, K. R., & Diaz Schiavon, A. L. (2022). Diffusing corporate sustainability knowledge with online education: experiences from a massive open online course (MOOC) on sustainable fashion. *Journal of International Education in Business*, 15(1), 89–105. <https://doi.org/10.1108/JIEB-02-2021-0026>
- Pérez, A., Collado, J., & Liu, M. T. (2022). Social and environmental concerns within ethical fashion: general consumer cognitions, attitudes and behaviours. *Journal of Fashion Marketing and Management: An International Journal*, 26(5), 792–812. <https://doi.org/10.1108/JFMM-04-2021-0088>
- Purnama, R., Tajuddin, R. M., & Shariff, S. M. (2022). Examining Students' Attitudes towards Sustainable Fashion Design Curriculum. <https://doi.org/10.2991/assehr.k.220601.052>
- Qu, Z., Huang, W., & Zhou, Z. (2020). Applying sustainability into engineering curriculum under the background of “new engineering education” (NEE). *International Journal of Sustainability in Higher Education*, 21(6), 1169–1187. <https://doi.org/10.1108/IJSHE-11-2019-0342>
- Radclyffe-Thomas, N. (2018). Designing a sustainable future through fashion education. *Clothing Cultures*, 5(1), 183–188. https://doi.org/10.1386/cc.5.1.183_1
- Rashidi-Sabet, S., & Madhavaram, S. (2022). A Strategic Marketing Framework for Emerging Out of the Climate Change Social Trap : The Case of the Fashion Industry. *Journal of Macromarketing*, 42(2), 267–291. <https://doi.org/10.1177/02761467211058083>
- Ray, S., & Nayak, L. (2023). Marketing Sustainable Fashion: Trends and Future Directions. In *Sustainability (Switzerland)* (Vol. 15, Issue 7). MDPI. <https://doi.org/10.3390/su15076202>



- Ritch, E. L. (2022). Consumer interpretations of fashion sustainability terminology communicated through labelling. *Journal of Fashion Marketing and Management*, 26(5), 741–758. <https://doi.org/10.1108/JFMM-03-2021-0075>
- Rodrigues Da Rocha, O., Dublin, T. U., Kamphambale, D., & Coetzer, J.-H. (2024). Education for Sustainability-Are we Forgetting the Economic Education for Sustainability? *Irish Journal of Academic Practice*, 11(2), 1–24. <https://arrow.tudublin.ie/ijap/vol11/iss2/3>
- Romero, V. F., Foreman, J., Strang, C., Rodriguez, L., Payan, R., Bailey, K. M., & Olsen, S. (2022). Racial equity and inclusion in United States of America-based environmental education organizations: a critical examination of priorities and practices in the work environment. *Journal of Outdoor and Environmental Education*, 25(1), 91–116. <https://doi.org/10.1007/s42322-022-00099-w>
- Schmitz, M. A., Cordova, M., Cankar, T., & Marko-Wieser, L. (2024). Exploring the Sustainability Mindset for Management Education with a Focus on Social Sustainability. In *The Palgrave Handbook of Social Sustainability in Business Education* (pp. 465–483). Springer Nature Switzerland. https://doi.org/10.1007/978-3-031-50168-5_24
- Shah, R., & Brett, P. (2021). Global citizenship education in Nepal. *International Journal of Development Education and Global Learning*, 13(2). <https://doi.org/10.14324/ijdegl.13.2.05>
- Shephard, A. J., & Pookulangara, S. A. (2022). Teaching slow fashion: an inquiry-based pedagogical approach. *International Journal of Fashion Design, Technology and Education*, 15(1), 109–119. <https://doi.org/10.1080/17543266.2021.2013958>
- Tripathi Nautiyal, V., & Atre, A. (2022). A study on consumer behaviour of urban Indian working women towards office wear outfits and sustainable fashion. *ShodhKosh: Journal of Visual and Performing Arts*, 3(2), 226–235. <https://doi.org/10.29121/shodhkosh.v3.i2.2022.152>
- Van Rompay-Bartels, I., & Tuninga, R. S. J. (2023). Toward a model of global citizenship in business education. *Journal of Transnational Management*, 28(1–2), 5–34. <https://doi.org/10.1080/15475778.2023.2223096>
- Velasco-Molpeceres, A., Zarauza-Castro, J., Pérez-Curiel, C., & Mateos-González, S. (2023). Slow Fashion as a Communication Strategy of Fashion Brands on Instagram. *Sustainability (Switzerland)*, 15(1). <https://doi.org/10.3390/su15010423>
- Wood, J., Redfern, J., & Verran, J. (2023). Developing textile sustainability education in the curriculum: pedagogical approaches to material innovation in fashion. *International Journal of Fashion Design, Technology and Education*, 16(2), 141–151. <https://doi.org/10.1080/17543266.2022.2131913>



057-032

EXPLORING PEDAGOGY COMPONENTS USED BY THE LECTURER TO TEACH QUANTITY SURVEYING MEASUREMENT COURSES: A PILOT STUDY

Atikah Binti Razali (Ph.D candidate)
International Islamic University Malaysia, Malaysia
Email: atikahrazali@gmail.com, Tel: +6018-3830334

Assoc. Prof. Dr Suhailah Binti Hussien
International Islamic University Malaysia, Malaysia
Email: suhailah@iium.edu.my, Tel: +603-64215382

Prof. Dr. Tunku Badariah Binti Tunku Ahmad
International Islamic University Malaysia, Malaysia
Email: tbadariah@iium.edu.my, Tel: +603-64215380

Assoc. Prof. Dr Mohd Burhan Bin Ibrahim
International Islamic University Malaysia, Malaysia
Email: mburhan@iium.edu.my, Tel: +603-64215349

ABSTRACT

This study is to explore the pedagogical components used by the lecturer to teach Quantity Surveying Measurement Courses (QSMC). According to the literature review, relatively little study has been conducted on the pedagogical components utilised in teaching QSMC, despite the fact that they are critical aspects for successful and efficient instruction. Pedagogical components for teaching QSMC for this study, were adapted from the Herbart theory of five components of pedagogy. Due to the complexity of the QSMC, which creates challenges among the lecturers and learning difficulties among the students, pedagogical components can be proposed as one of the strategies for effective teaching. In order to come up with the pedagogical components framework for teaching QSMC, a semi-structured interview and classroom observation were conducted with a volunteer participant, a QSMC lecturer from Quantity Surveying Higher Education Provider (QS HEP). Based on the findings, there are three most prominent components of pedagogy used for teaching QSMC, namely preparation, presentation, and application. The research findings benefit QSMC lecturers as a reference for a pedagogical foundation framework for teaching QSMC and contribute to the marketability of graduates in the field of Quantity Surveying (QS). It contributes to the development of strategies that suit the needs of the QS learning process.

Keywords: Quantity Surveying, Education, Measurement Courses, Pedagogy Components.

INTRODUCTION

Since the 1990s, a variety of factors influencing the demand for Quantity Surveying (QS) courses have made it difficult for QS higher education providers (HEP) to find more innovative and effective approaches to ensure that the skill base is not eroded while serving the needs of



the construction industry. The primary core activity of a Quantity Surveyor (QS) in construction projects is measurement work. Measurement work is a fundamental competency and ability that QS graduates should obtain by taking the Quantity Surveying Measurement Course (QSMC). QSMC is a complex course that integrates multiple knowledges theoretically and practically, necessitating the application of proper pedagogy in its instruction, particularly the pedagogical components (Lee, 2013). Therefore, it is very important to document the teaching practices of the QS lecturer for teaching QSMC because QSMC is a complex subject that requires appropriate steps for effective teaching that can further be referred to as a reference for others (Lee, 2013; Yusof et al., 2018).

Even though the programme is professional in nature which makes more focus on the content knowledge is the primary concern of the lecturer, but without appropriate steps in teaching, it will lead to ineffective teaching such as a breakdown of knowledge and cause learning difficulties for the students, and worst of all, it may affect the quality of the QS graduates (Gurmu et al., 2021). Yusop et al. (2018) and Owstroski (2011) have discovered the learning difficulties faced by the students in learning QSMC, but not much research has been done to get the perceptions of the lecturers', particularly on the pedagogical components of teaching QSMC. Even though the QS programme has been offered for about seven decades, very little has been written about the teaching practices used by the QS lecturers in teaching QSMC. In fact, lecturers are the ones that will face the students directly and will ensure no breakage of knowledge at the stage of transferring the knowledge to the students in the classroom, and their experiences are really precious to be documented for references by other QSMC lecturers.

The development of the pedagogical components framework for teaching QSMC is very important because the appropriate pedagogy used results in effective teaching (Gurmu et al., 2021; Lee, 2013; Owstrowski, 2011; Rahmat et al., 2016). However, there are very few written discussions on the pedagogies for teaching QSMC from the QSMC lecturers, particularly the pedagogical components. Therefore, this research intends to explore the pedagogical components of teaching for QSMC from the perspective of QSMC lecturer at a selected QS higher education institution.

PEDAGOGICAL COMPONENTS

The phrase 'pedagogical components' is part of the broad meaning of the term pedagogy. According to Rutto (2017), pedagogy is the theory and practice of education, and the primary concerns are the knowledge and skills of teaching involved by the teacher, the learner, and the knowledge that they produce due to the interactions. Moreover, according to Oxford Learner's Dictionaries (2024), the term component means one important or principal of several parts of which something is made. Therefore, 'pedagogical components' means the principal theory and practice of lecturers to expand or enhance the knowledge of the students. Due to the scarcity of literature about the pedagogical components framework for teaching QSMC, therefore, the pedagogical components theories from Herbart were used to develop as a foundation for the pedagogical components used for teaching QSMC. Pedagogical component theories by Johann Friederich Herbart (1776–1841, cited in Rutto, 2017) refer to postulates on how teaching should be done in order to encourage one to learn. According to Johann Friederich Herbart (1776–1841), there are five components of pedagogy, and these components of pedagogy are as follows:

- i. Preparation— is a process of relating new material to be learned to relevant past ideas or memories in order to give the students a vital interest in the topic;



- ii. Presentation—is presenting new material by means of concrete objects or actual experience;
- iii. Association—is a thorough assimilation of the new idea through comparison with former ideas and consideration of their similarities and differences in order to implant the new idea in the mind;
- iv. Generalisation—is a procedure especially important to the instruction of adolescents and designed to develop the mind beyond the level of perception and the concrete;
- v. Application—is using acquired knowledge not in a purely utilitarian way but so that every learned idea becomes a part of the functional mind and an aid to a clear, vital interpretation of life.

TEACHING PRACTICES BY LECTURER

It is significant to focus on the lecturers who teach QSMC because they are the ones who contribute a lot to providing high-quality teaching and will embrace effective teaching methods for the students (Kamardeen, 2015). They became aware of the corollary of the difficulties of learning faced by the students and tried to improve based on their experiences and feedback from the students (McLeod and Golby, 2003). In order to produce highly skilled talent QS graduates for the construction sector, the lecturer, who is the backbone of the university system, needs to reconfigure their pedagogies of teaching in order to meet the needs of employers in the country as well as in a global context (Azman, 2019; Safiah et. al., 2017). Therefore, their experiences, practices, and perspectives are very valuable in reshaping the education landscape to meet the needs of the country and globally (Premila and Singh, 2020). The QSMC lecturer's teaching practices will be structured based on the Herbart five components of pedagogy. According to Westbrook et al. (2013), "teaching practices" are the particular acts and discourses that happen throughout a class that physically execute the approach and strategy. Emulating Alexander (2001), teaching practices include the following:

- Lecturer-spoken discourse (including instruction, explanation, metaphor, questioning, responding, elaboration, and management talk).
- Visual presentation (using a chalkboard, writing, diagrams, pictures, textbook, and learning aids such as stones, experiments, and drama) to understand or construct the new knowledge being presented or indicated to the learners.
- The act of setting or providing tasks for learners to cognitively engage with content or develop physical skills, such as experimentation, reading, writing, drawing, mapping, rehearsing, problem solving, and practicing.
- There are a variety of social interactions in which language is central between learners or learners and lecturers, such as pairs, groups, individually, or whole-class.
- Lecturers' monitoring, use of feedback, intervention, remediation, and formative and summative assessment of the students or assessment by the students themselves.

QUANTITY SURVEYING MEASUREMENT COURSES (QSMC)

QSMC is a core subject for QS graduates to possess QS fundamentals, which is measurement work (Board of Quantity Surveying Malaysia, BQSM, 2019). Measurement work is the primary task of the QS in a construction project (Seeley, 1997). Therefore, QASC has developed standard programme requirements for QS higher education provider (HEP) that QSMC needs to be offered a minimum within five semesters of the study duration, should be 20–30% of the total credit of the programme, and should cover 90% of the content. Teaching QSMC integrates elements of theories such as theories in construction technology, skills in



reading drawings, principles of measurement and mathematics, skills in "taking off quantities," and preparing and presenting BQ. Hence, the QS lecturers should not only have in-depth knowledge of measurement techniques (content knowledge) but also general pedagogy knowledge (components of pedagogy) for effective teaching. Due to the multi-content knowledge as well as teaching skills required in teaching QSMC, QS lecturers faced challenges in delivering the courses (Gurmu and Mahmood, 2020; Lee, 2013; McDonnell, 2010; Yusof et al., 2018).

METHODOLOGY

Research methodology is a crucial part of conducting research because the suitability and validity of the methods applied for data collection determine the validity of the findings of the research (Frankfort-Nachmias and Leon-Guerrero, 2016). Due to the nature of the study, which is to explore the participant's experiences, attitudes, and beliefs in their own words, the appropriate research design implemented is qualitative research. Furthermore, the methods of data collection are an in-depth, semi-structured interview (Babbie, 2011; Rubin and Rubin, 2005) and classroom observation. An in-depth, semi-structured interview satisfies the exploration of the pedagogical components used for teaching QSMC from the perspective of the QSMC lecturer, whereas classroom observation is to observe the teaching practices, particularly the strategies and teaching patent, and it can be the bridge between the worlds of theory mentioned during interview sessions and practice (Reed & Bergemann, 2001).

PARTICIPANT

Only one volunteer participant was invited to take part in this pilot study since the target group of the actual data collection of the study is small, which is only six lecturers. The participant is a 45-year-old female QSMC lecturer at public QS HEP that offers a Bachelor Degree in Quantity Surveying Program. The lecturer chosen is actively teaching QSMC and has experience teaching QSMC since 2002. The participant is applicable for both data collection methods.

IN-DEPTH SEMI-STRUCTURED INTERVIEW

The face-to-face, semi-structured interview took place on January 5, 2022, at an undisclosed location, from 12 to 1 p.m. A proper draft of written notes, a voice recorder in the handphone, and, as a backup for any unavoidable circumstances, a digital voice recorder are used to avoid missing valuable information, as suggested by Ahmad (2017). The interview protocol followed the processes illustrated in Figure 1.

A series of interview questions was developed to explore the participant pedagogical components for teaching QSMC, and three members reviewed the instrument. The members checking included two expert lecturers in qualitative research with more than ten years teaching experience from the faculty of education, as well as a lecturer with eleven years of teaching experience from the quantity surveying field. The following are the interview questions constructed for the interview session.

1. Based on your experience, can you share how you teach measurement courses?
2. How do you handle the lectures and tutorial sessions of the measurement class?
3. What materials and tools do you use in your teaching and tutorial sessions?



Other related documents were prepared, including an invitation letter, a consent form for the participant, specifically for ethical procedures and data confidentiality, as well as requesting permission to record the interview session, a research information sheet, and an interview guide.

Figure 1: Research Operational for interview

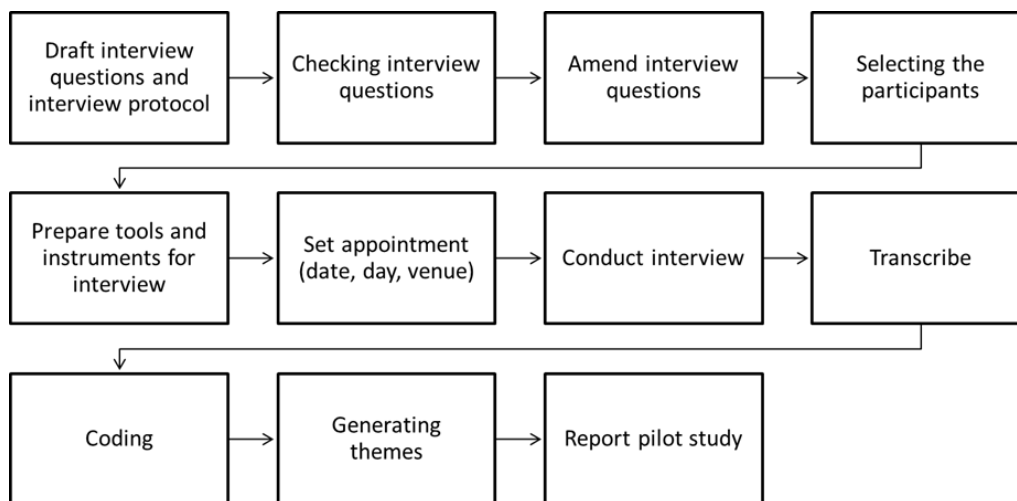

The method of data analysis for the interview was thematic analysis, which has four stages, as illustrated in Figure 1. The thematic analysis was modified from both Ahmad (2017) and Creswell (2013). The first stage is data transcription, which arranges the interview data in a dialogue form known as verbatim transcription and follows the transcription protocol by Azevedo et al. (2017). The transcription was done manually without any apps or software since there was only one participant involved. The second stage is data categorization, which involves the coding process. The coding process is to generate the main ideas from the verbatim transcription. The third stage is to produce themes from the main ideas generated in the second stage by merging the key concepts of “pedagogical components” used by the QSMC lecturer. The last stage is reporting the formulated themes, which will be discussed in the findings and discussions.

CLASSROOM AND STUDIO OBSERVATION

The physical classroom observation was conducted on December 27, 2023, from 10.17 a.m. until 5 p.m. The observation for the lecture session was conducted from 10.17 a.m. until 11 a.m. in the briefing room, and then the tutorial session was held at QS Studio from 11 a.m. until 5 p.m. in the participant working institution. Students are given flexible time to go to lunch, prayer, or the washroom. Only one observation was conducted, which was in Week 11 on the topic of complex roof trusses. The QSMC class is for third-year students and consists of 37 students. The participant avoids giving permission for any video recording during the observation. Therefore, a proper checklist and reflective note were prepared to jot down important information. The checklist is to record the teaching practices for both lecture and tutorial sessions with the intention of getting the patent and strategies of teaching QSMC. The content of the checklist was structured into three parts: at the beginning of the lesson (pre-interactive), during the lecture session (interactive), and at the end of the lesson (post-interactive). Table 1 shows a series of guiding questions were developed and the instrument



was checked by supervisory committees, lecturers with more than fifteen years of teaching experience from faculty of education.

Table 1: Guiding questions and teaching practices

Guiding Questions		Patent & strategies
Lecture session	Tutorial session	
How does the lecturer start the class?	How does the lecturer start the tutorial session?	Pre-interactive or beginning the lesson
How does the lecturer deliver the contents, handling the teaching activities in the class, ensure that students understand the lecture, maintain the students' motivation in the class, and use the teaching aid and materials during the lecture session?	How does the lecturer handle and monitor the the understanding of the students during the tutorial session?	Interactive is the activities of teaching practices
How does the lecturer close the lecture session?	How does the lecturer close the tutorial session?	Post-interactive (end of the lecture session)

The observation protocol followed the processes illustrated in Figure 2. The guiding questions for observation were developed based on the analysis from the pilot study from the interview data. Other related documents were prepared, including an invitation letter, a consent form for the participant, specifically for ethical procedures and data confidentiality, as well as requesting permission to record the observation, a research information sheet, and an observation checklists.

Figure 2 The research operational framework for classroom observations

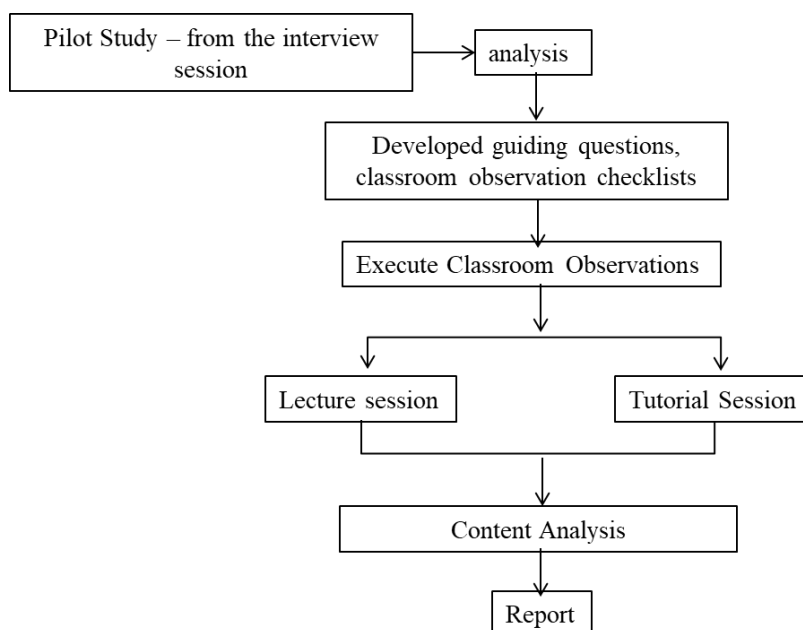

The data of the classroom observation analysed based on the content analysis of the observation sheet or observation checklists provided which are divided into three teaching stages; pre-



interactive or preliminary activities, interactive (main activities), and post-interactive (closing activities) as in Table 1.

FINDINGS AND DISCUSSIONS

Based on the findings, the teaching of QSMC by the participant has three prominent pedagogical components: preparation, presentation, and application, according to the theory of Herbart's five components of pedagogy. Moreover, the findings from classroom observation revealed the patent and strategies for teaching QSMC in three stages: pre-interactive, interactive, and post-interactive, as discussed below.

PEDAGOGICAL COMPONENT 1 - PREPARATION

The findings show that the scope of preparation not only refers to the stage to begin the teaching in the class, but it also needs to consider how the participant prepares before the teaching. Therefore, the preparation of the participant before starting the class focuses on the essential pedagogical aspects such as choosing an appropriate teaching method, venue, time allocation, teaching techniques, and teaching aids such as the tools and materials discussed in detail by Alexander (2001) in the abovementioned teaching practices. Based on the participant perspective (DU 10), the teaching method used for the lecture session is the traditional lecture method. The traditional lecture method is the most widely used form of presentation, where the lecturer is at the front of the classroom talking to the students (Awang, 2014). The participant chose the lecture method due to the content knowledge of the courses, which is to give an understanding of the principles of measurement.

I think we always done measurement traditional way whereby we give them lecture first, for every topic... (DU 10)

Another aspect discussed by the participant is the time allocation, which is also important to be planned before the class begins. For example, the participant allocated 1 and a half to 2 hours for the lecture session, and the remaining hours are meant for the tutorial session.

...we give them 1 hour and half to two hours lecture first and then we start going to the studio to do hands on measurement work, and read the drawings with the students. (DU 10)

In order for the class to begin in accordance with the schedule given by the institution, the participant booked the venue before the class started. Another aspect of the venue is the appropriateness of the venue used. For instance, for a lecture session, the appropriate venue is a lecture room or lecture hall inclusive of technology tools such as a computer set, LCD projector, microphone, whiteboard, markers, internet connection, flip seating for students, a good sound speaker, and a comfortable environment. In contrast, the venue for the tutorial session is a studio that consists of portable whiteboards, colourful markers, and a large table that is comfortable to place an A1 or AO-sized set of drawings prior to doing hands-on measurement work. In association with the booking of the venue, it is also important to focus on the availability, safety, and functionality of all the teaching aids for teaching purposes.

Teaching techniques is another significant aspect mentioned by the participant as part of the preparation before starting the class. The aspects of teaching techniques mentioned by the



participant were: questioning and answering during the lecture session; using PowerPoint slides for presentation technique; communication techniques such as using language that students can easily understand; creating a good relationship and mood by greeting the students; delivery techniques such as making sure the voice is clear; using eye-catching presentation slides, photos, and videos; being more visual for complicated construction items; and the technique of evaluation such as assignments, projects, and tutorial tasks.

PEDAGOGICAL COMPONENT 2 - PRESENTATION

The prominent pedagogical component 2 is presentation which is presenting new material by means of concrete objects or actual experience (Herbart, cited in Rutto, 2017). The participant has mentioned that the presentation technique is giving the lecture guided by the slide presentation. The critical part is to plan for the flow of content knowledge to be delivered in the class. According to the participant, the presentation flow is guided by the notes prepared in the slide presentation. The content knowledge that was prepared by the participant in the slides focused on related knowledge of construction technology and the explanation or interpretation of the relevant clauses in the Standard Method Measurement (SMM).

Based on DU 18, the participant started the lecture by revising the knowledge of the students on the related construction technology that they should gain from construction technology courses. This is to familiarise the students with the components and construction methods for the topic that they learned. The identification of the components of items helps to give the students an understanding of the items that they have to measure for the building element, as well as preparing the list of taking-off (list of items to be measured). The construction method is to expose the students to certain requirements of machinery and workmanship that they should understand in order to write in the text of the description in accordance with the SMM requirements.

few of the slides is to revise the students' knowledge on construction technology, then we go one by one following related clauses in the SMM theoretically. (DU 18)

The participant, as in DU 30 and DU 56, has mentioned that nowadays, using videos, particularly to provide visualisation for the students about construction technology, is common. The participant mentioned that the links to the videos provided on the e-learning platform allow the students to assess them anytime, from anywhere. Furthermore, in DU 68, the participant also mentioned that instead of using interactive PowerPoint presentations and videos, using a lot of photos is also one of the alternatives to give the students understanding through visualisation.

*So nowadays the presentation slides contain video....(DU 30)
For certain topics which are complicated, I used video (DU 56)
I used powerpoint, video, materials tu like photos,(DU 68)*

The participant in DU 20 and DU 28 has mentioned that the explanation or interpretation of related clauses in SMM was done by giving an understanding of the important information needed from the clauses that need to be stated in the text of the description.



*I normally say that what SMM stated in the clauses should be written in the text of description (DU 20)
 I go one by one la for any related clauses... (DU 28)*

Based on DU 46, the participant has mentioned that the technique to monitor the students, to create engagement with the students, and to assess the understanding of the students is by calling randomly or specifically the students' name, or some time just asking the question generally for all the students. The participant also provides a variety of assessment methods, such as quizzes, tutorials, and infographics such as posters or videos.

*Call out name. We call out name. the names of the students that I remember....
 So that's how we try to ask... then to ensure that they really understand
 or not, sometimes we have quizzes, so quizzes are part of the continuous
 assessment method.. tutorial, quiz,..try to ask them to make infographic,
 posters or videos.. (DU 46)*

PEDAGOGICAL COMPONENT 3 - APPLICATION

The third prominent pedagogical component mentioned by the participant is application. As stated by the participant in DU 10 in the abovementioned before is the allocation time for the tutorial session. Cooperative and demonstration learning were applied by the participant for the tutorial session. The participant used these methods because the tutorial is to provide the students with the task given that trains them on the application of the theoretical measurement principles that they learned during the lecture session into reality. The role of the participant during the tutorial as facilitator is to monitor the students work in groups and to demonstrate if any questions rose by the students pertaining to measurement work.

*..we have divided for these students into 8 groups. So in a group have 5
 students. So after lecture we went to studio, for the students to read
 drawings, so we will go around from one table to another, or we
 seat at the front table..(DU 10)*

As stated in DU 46, the participant provides tutorials for each topic that they have covered. In DU 10, the participant also mentioned that the tutorial is for the students to go hands-on with the measurement work in groups. The participant will go around from table to table to assist the students, and if there are any questions, the participant will demonstrate the measurement work at the group tables or at the portable whiteboard provided in the studios. Therefore, at the application stage, the participant used the teaching support material, such as the whiteboard, to demonstrate the principles of the measurement, such as the mensuration to be applied, or to sketch some part of the 2D drawings in 3D to improve the visualisation of the students. Thus, the variety of marker colours is very important to indicate the important image that the participant sketches.

TEACHING PATENT AND STRATEGIES FOR LECTURE SESSION

The first step in teaching is the process of relating new material to be learned to relevant past ideas or memories in order to give the students a vital interest in the topic (Herbart, cited in Rutto, 2017). This is a delivery technique at the beginning of the class (pre-interactive). Based on observation in the class, the participant started the class by giving *Salam* and reciting *Doa*. The participant greets the students, such as by asking them whether they have taken their



breakfast or not. This is to create a relaxed and good-mood environment before starting the lecture. The participant has prepared all the teaching support, such as the venue, teaching tools and facilities, and slide presentation. The participant refreshes the knowledge of the students by relating the topic of the day to the topic a week before, just to give them an idea of the topic. The participant clearly outlines the learning objectives and the lectures guided by the PowerPoint slides. The pre-interactive took place for an estimated 6 minutes.

The skills needed to develop and present a lecture are the critical part of the interactive stage. Based on the observation during the lecture session, it was estimated that about twelve minutes were spent by the participant on the revision and identification of the items of components and construction methods. The PowerPoint prepared by the participant was in point form, inclusive of photos of each component of the items to be measured with the standard specification of the items. The participant used a microphone for a clear voice, which the students could hear clearly. The PowerPoint font and colour were nice, as they were easily readable and understood. The participant has provided the video link on the e-learning platform so that the students can assess and watch the complicated construction methods to improve their visualisation of the topic discussed. The photos play an important role as they are very useful to gain the attention of the students, as most of the students focus on the slides displayed by the participant. Some important contents of construction technology delivered by the participant include the steel structures, components of trusses, and connections for the steel. For instance, for steel roof truss components have to mention in the description about the size, thickness and the unit is to convert to unit kilogram (kg).

After finished the explanation on the construction technology, the lecturer spent about twelve minutes to explain related clauses in the SMM together with the unit of the items to be measured, the measurement of the items and the information that should be stated in the text of description. The last content of knowledge delivered by the participant during the presentation was estimated to be about twelve minutes to sample drawings for complex steel roof trusses and refresh the students on the components to be measured before dismissing the class and proceeding to the studio for a tutorial session. The participant ends the class by reciting *Doa*.

TEACHING PATENT AND STRATEGIES FOR TUTORIAL SESSION

However, based on the observation during the tutorial session, the participant started the session by briefing the students on the task that they should do on the day, which is to measure the elements of complex roof trusses and the distribution of the set of A1-sized drawings. Since the students are third-year students, basic skills for QS students, such as how to use a scale ruler and dimension papers, are not necessary because they should gain such skills during their first year. The table in the studio is large which is portion to place the A1-sized drawings. There were about 8 groups that each group consists of 5 members. The participant let the students did the measurement work in the groups and from time to time the participant went around from table to group table. Sometimes, the students came to the participant which sat at the front of the studios.

The common questions raised by the students were about understanding the drawings, the measurement to be applied, the unit of measurement, and the interpretation of the SMM clauses that mentioned what information the students should write in the text of description. The participant answered or explained the students questions using a variety of strategies, such as sketching on the whiteboard with a multicolor marker and giving an explanation. Sometimes



the participant gave links to videos for the students to get a visual of the drawings or items that were unfamiliar to them to watch. Sometimes, the participant sketched on the student's drawings that were asked. Sometimes the participant refers to the SMM if they have questions about it. Sometimes the participant used the calculator and scale ruler for any calculation of the items. For a particular measurement, such as the calculation of a mild steel plate, the participant demonstrated the calculation of the mild steel, which involved the provision of a conversion table.

From the observation, it was estimated that about seventeen questions were asked by the student from 11.30 a.m. until 5 p.m., and about nine questions were asked before 3 p.m. It took about at least 30 minutes for the students to read the drawings, understand the drawings, and start to ask questions. The following were examples of questions raised by the students, which can further be considered the frequently asked questions (FAQ) for the next batch of students:

- To make an assumption on the material size
- To read the drawing, identify the location of the items to be measured, such as struts, top chord, and bottom chord.
- The unit of measurement for painting, purlin, and sagrol
- The calculation of a mild steel plate
- The specification of construction methods such as welded types for description

The participant ends the tutorial work by asking the students to submit the tutorial work for the next week and ends the class by reciting *Doa*.

CONCLUSION

In conclusion, there are three prominent pedagogical components that can be as a framework for teaching QSMC, as illustrated in Figure 3. The prominent pedagogical components for teaching QSMC are preparation, presentation, and application. The important aspects of preparation are choosing the appropriate teaching method, teaching techniques, booking the venue and teaching aid, and time management. Commonly, the QSMC teaches in two phases: a lecture session in the lecture hall and a tutorial session in the studio. In order to ensure the class can be taught according to the schedule fixed by the institution, it is recommended to book the venue earlier to ensure its availability and functionality. The recommended time allocation for a lecture session is 1 and a half to two hours, and the rest of the time is for a tutorial session. There are significant aspects of the presentation components: the skills of presentation of the lecture, the flow of the content of knowledge in the slides, the interactive and informative slide contents, such as the content of principles of measurement, photos, and videos, and the communication technique to create engagement and monitor the understanding of the students. The critical aspects of application components are to master the skills of cooperative and demonstrative learning methods.



Figure 3 Prominent Pedagogical Components for Teaching QSMC

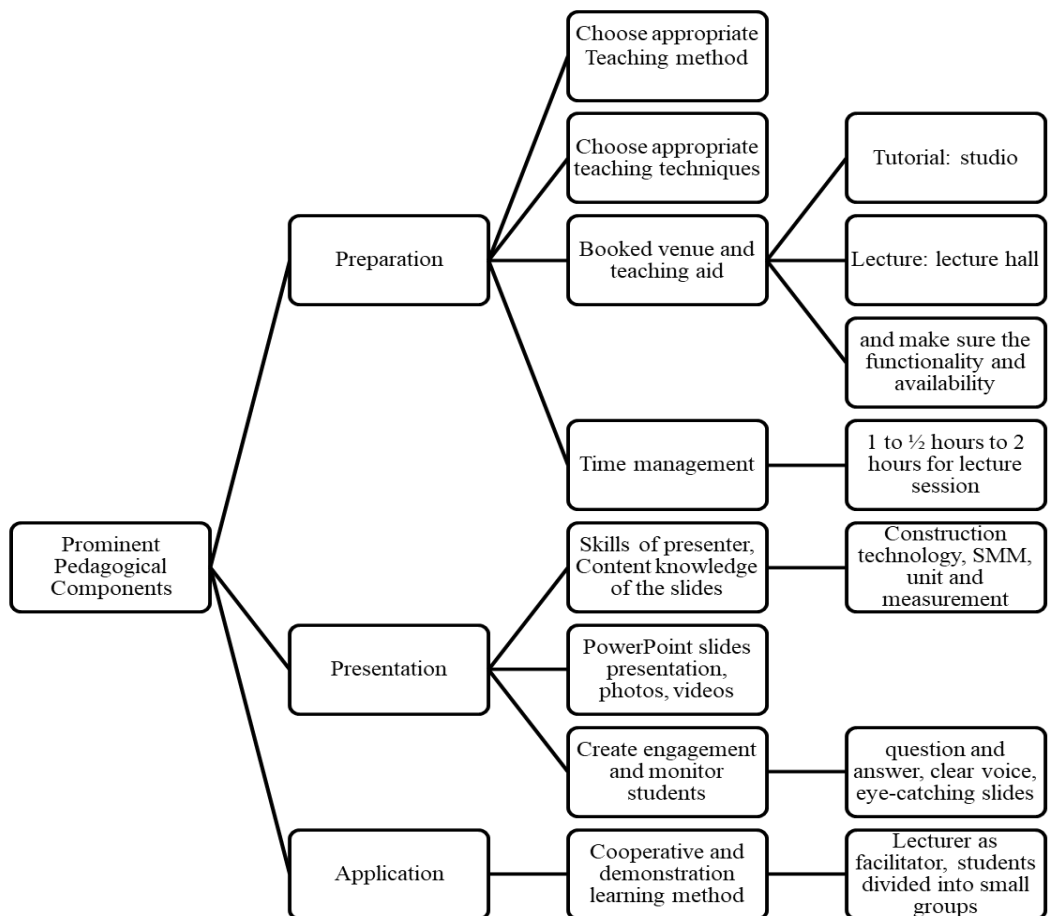

The patent and strategies of teaching for QSMC is divided into lecture and tutorial sessions. The purpose of the pre-interactivity during the lecture session is to create a good environment and grab the attention of the student to the topic to be learned, while briefing the student on the task given during the tutorial session to help them understand what they should do. Moreover, for the interactive lecture session, the focus is more on lecturing the content of the topic, whereas during the tutorial sessions, the focus is on facilitating based on the questions raised by the students. Furthermore, for the post-interactive session, both sessions refreshed the students with the objectives and date of submission and closed the class with reciting *Doa*.



Figure 4 Teaching patent and strategies for teaching QSMC

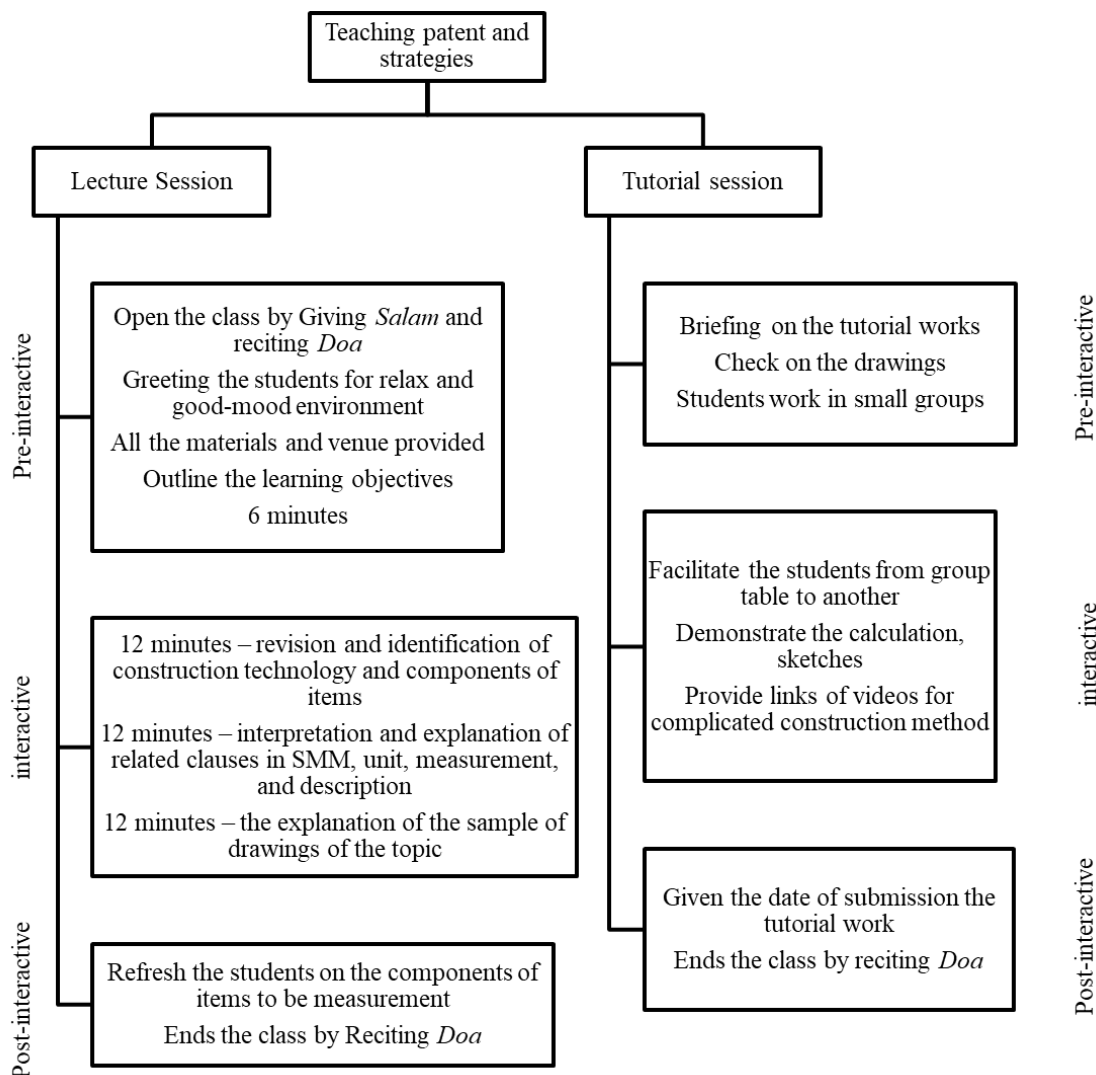

REFERENCES

Ahmad, I. S. (2017). *Doing Qualitative Research for Beginners: From Theory to Practice*. Partridge Publishing: Singapore.

Alexander, R. J. (2001). *Culture and pedagogy: International comparisons in primary education*. Blackwell publishing.

Azman, N. (2019). *Higher Education in Malaysia: A critical review of the past and present for the future*. (Ed. Chang Da Wan, Morshidi Sirat and Dzulkifli Abdul Razak). Universiti Sains Malaysia: Penang

Azevedo, V., Carvalho, M., Fernandes-Costa, F., Mesquita, S., Soares, J., Teixeira, F., & Maia, Â. (2017). Interview transcription: conceptual issues, practical guidelines, and challenges. *Revista de Enfermagem Referência*, 4(14), 159-167.

Babbie, E. (2011). *The Basics of Social Research (5th ed.)*. United States of America: Wadsworth Cengage Learning.

BQSM, (2019). *Accreditation Manual for Quantity Surveying Programmes*. 3rd Edn. Quantity Surveying Council: Kuala Lumpur.



- Creswell, J. W. (2013). *Qualitative Inquiry & Research Design Choosing Among five Approaches*. 3rd. edn. SAGE Publication: United States of America.
- Frankfort Nachmias, C., & Leon-Guerrero, A. (2016). *Social statistics for a diverse society*. Sage Publications.
- Gurmu, A., Kamardeen, I., & Mahmood, M. N. (2021). Blended pedagogical model for effective teaching of building measurement and estimating. *International Journal of Construction Management*, 1–10. doi:10.1080/15623599.2021.1957752
- Gurmu, A. T., & Mahmood, M. N. (2020). Investigation of learning challenges in building measurement unit. *International Journal of Educational and Pedagogical Sciences*, 14(2), 144-150.
- Kamardeen, I. (2015). Critically reflective pedagogical model: a pragmatic blueprint for enhancing learning and teaching in construction disciplines. *Construction Economics and Building*, 15(4), 63-75.
- Lee, C. C. (2013). An Interactive Approach To Teaching Quantity Surveying Measurement. *ICERI2013 Proceedings*, 3862-3871.
- Macleod, F., & Golby, M. (2003). Theories of Learning and Pedagogy: issues for teacher development. *Teacher Development*, 7(3), 345-361.
- McDonnell, F. P. (2010). The relevance of teaching traditional measurement techniques to undergraduate quantity surveying students. *Journal for Education in the Built Environment*, 1-15.
- Ostrowski, S. (2011, September). Solutions to the pedagogical difficulties with measurement in quantity surveying. Conference Proceeding. In *RICS Construction and Property Conference* (p. 829).
- Oxford Learner's Dictionaries. (2024). Oxford Learner's Dictionaries Online. Oxford University Press. Retrieved at <https://www.oxfordlearnersdictionaries.com/>
- Premila, S. P., & Singh, G. S. (2020). A Study of the Use of Online Assessments in a Blended Learning Environment in a Private Higher Education Institution in the Klang Valley. *ASEAN Journal of Open Distance Learning*, 12(1), 1-11.
- Rahmat, N. H., Saidin, N, Zulkifli, V., & Dahlan, N. A. (2016). *Teaching and Learning in Class: Issues and effective approaches*. (Ed. Noor Hanim Rahmat and Norshiha Saidin). UiTM Press: Selangor.
- Reed, A. J. S. & Bergemann, V. E. (2001). *A Guide to Observation, Participation, and Reflection in the Classroom*. Boston: McGraw Hill.
- Rubin, H. J. & Rubin, I. S. (2005). *Qualitative Interviewing The Art of Hearing Data*. (2nd. Ed.). California: Sage Publications, Inc.
- Rutto, D. (2017). Pedagogical Theories. *International Journal of Scientific & Engineering Research*, Vol. 8, Issue 6, pg. 2025-2030).
- Safiah, S., Massila, K., & Razilah, A. R. (2017). THE MANIFESTATION OF VARIETIES OF BLENDED LEARNING PEDAGOGY IN HIGHER EDUCATION. *Journal of Human Capital Development (JHCD)*, 10(1), 101-121.
- Seeley, I. H. (1997). *Quantity surveying practice* (Vol. 7). London: Macmillan.
- Shafie, H., Khuzzan, S. M. S., & Mohyin, N. A. (2014). Soft skills competencies of quantity surveying graduates in Malaysia: employers' views and expectations. *International Journal of Built Environment and Sustainability*, 1(1).
- Tunji-Olayeni, P. F., Amusan, L. M., Omuh, I. O., Afolabi, A. O., & Ojelabi, R. A. (2016). Learning difficulties in building measurement.
- Watson, P. (2002). The role and integration of learning outcomes into the educational process. *Active learning in higher education*, 3(3), 205-219.
- Westbrook, J., Durrani, N., Brown, R., Orr, D., Pryor, J. & Salvi, F. (2013). *Pedagogy, curriculum, teaching practices and teacher education in developing countries*. Final



report. Education Rigorous Literature Review. EPPI-Centre, Social Science Research Unit, Institute of Education, University of London.

Yogeshwaran, G., Perera, B. A. K. S., & Ariyachandra, M. M. F. (2018). Competencies expected of graduate quantity surveyors working in developing countries. *Journal of Financial Management of Property and Construction*.

Yusop, N., Derus, M. M., Bakar, N. A., Saberi, M. H., & Abdullah, M. A. (2018). Technical skills in quantity surveying and relevant practices: Discipline standards. *International Journal of Academic Research in Business and Social Sciences*, 8(9).

Zakaria, N., Munaaim, M. C., & Chan, S. I. (2006). Malaysian quantity surveying education = framework. Centre of project and facilities, University of Malaya.



063-037

APLIKASI AUGMENTED REALITY (AR) BAGI TOPIK BENTUK GEOMETRI 3D DALAM KALANGAN PELAJAR TINGKATAN 2

Fakharudin Shahudin

Fakulti Pendidikan, Universiti Kebangsaan Malaysia,
43600 UKM Bangi, Selangor, Malaysia.

Email: padinshah@gmail.com, Tel: 012- 3939440

Norazah Mohd. Nordin

Fakulti Pendidikan, Universiti Kebangsaan Malaysia,
43600 UKM Bangi, Selangor, Malaysia.

Email: dmmn@ukm.edu.my, Tel: 019 – 3328704

*Pengarang bersama

ABSTRAK

Pendidikan digital memiliki potensi besar dalam meningkatkan kualiti sistem pendidikan dengan sebaran maklumat tanpa had dan sempadan. Situasi ini menjadikan pendekatan pembelajaran masakini telah mula berubah dengan begitu ketara dengan penggunaan gajet dan aplikasi teknologi banyak memberi impak positif dalam sistem pendidikan. Kecenderungan trend pembelajaran yang berpandukan teknologi menjadikan proses pengajaran dan pembelajaran lebih bermakna dan menarik. Pembelajaran melalui aplikasi teknologi menjadikan pembelajaran lebih fleksibel, interaktif dan ruang masa untuk belajar secara eksplorasi dan inkuiri secara sendiri. Namun, penting bagi pengajar dan pelajar untuk memilih aplikasi yang berkualiti dan relevan supaya penggunaan aplikasi teknologi harus selaras dengan strategi pembelajaran yang efektif dan terintegrasi dalam konteks pendidikan yang lebih luas. Pemasalahan pelajar tidak boleh membuat visualisasi tentang keadaan sebenar berkaitan topik matematik dan pendekatan pembelajaran yang masih rendah dalam pengaplikasian penggunaan sumber atau bahan pengajaran interaktif mempengaruhi motivasi dan minat dalam pembelajaran matematik. Tujuan kajian ini adalah bagi mereka bentuk dan membangunkan aplikasi pembelajaran menggunakan *Augmented Reality* (AR) bagi mata pelajaran Matematik sekolah menengah dalam topik Bentuk Geometri 3D dalam kalangan pelajar Tingkatan 2 bagi menarik minat pelajar supaya ianya lebih menarik serta dapat membuat visualisasi dan menggambarkan keadaan sebenar. Proses pembangunan aplikasi ini diadaptasi dari Model reka bentuk pengajaran ADDIE yang mengandungi lima fasa iaitu Analisis, Reka Bentuk, Pembangunan, Pelaksanaan dan Penilaian. Kaedah tinjauan dengan menggunakan soal selidik telah dijalankan terhadap 27 orang pelajar Tingkatan 2 di sebuah sekolah di Temerloh, Pahang untuk mendapatkan pandangan mereka mengenai penggunaan *Augmented Reality* (AR) dalam pembelajaran mereka di sekolah. Dapatan kajian menunjukkan pelajar mempunyai minat dan pengetahuan yang tinggi terhadap mata pelajaran Matematik melalui penggunaan aplikasi berasaskan *Augmented Reality* (AR). Cadangan kajian masa hadapan adalah mengkaji aplikasi yang sesuai dan memberi impak terbaik dalam topik-topik berfokus matematik supaya menjadi rujukan kepada sistem pendidikan digital yang kian berkembang.



Kata Kunci: Pendidikan Digital, *Augmented Reality*, Gajet, Matematik, Aplikasi.

PENDAHULUAN

Kurikulum Matematik, berdasarkan Falsafah Pendidikan Kebangsaan, menyediakan pengetahuan dan kemahiran matematik yang komprehensif untuk mengatasi cabaran realiti semasa yang sejajar dengan perkembangan sains dan teknologi masa kini (KPM, 2013). Pelaksanaan Kurikulum Matematik, seperti yang dijelaskan dalam Dokumen Standard Kurikulum Dan Pentaksiran (DSKP), memungkinkan hubungan antara pengetahuan konseptual dan prosedural serta mengaitkan matematik dengan bidang lain, meningkatkan pemahaman dan relevansi matematik dalam kehidupan. Dalam era Kemahiran Abad Ke-21, penekanan pada kemahiran berfikir, hidup, dan kerjaya bertumpu pada praktik nilai murni, sementara pendekatan pembelajaran yang mengintegrasikan teknologi menjadi penting dalam pendidikan kontemporari. Kesan pandemik COVID-19, yang menyebabkan peralihan ke pendidikan digital, menunjukkan perlunya teknologi dalam menyokong pembelajaran berkualiti dan terancang. Pendidikan teknologi mendorong inovasi dan pemikiran kreatif, mempersiapkan generasi untuk bersaing dalam dunia kerjaya yang dinamik dan kompleks (KPM, 2013; WHO, 2020; Eboy et al., 2022).

Aplikasi *Augmented Reality* (AR) memfasilitasi interaksi antara dunia nyata dan objek maya, menyediakan alternatif pendidikan yang berpotensi mempengaruhi prestasi pelajar (Jafari et al., 2023). Dalam pengajaran matematik, AR semakin berkembang sebagai alat yang mampu meningkatkan pemahaman konsep matematik (Iwit et al., 2022). Namun, pelajaran matematik dianggap sulit dan abstrak, mengakibatkan kurangnya keyakinan dan motivasi dalam pembelajaran (Hui et al., 2021; Azlan et al., 2017; Mohd Shafian et al., 2021). Penggunaan AR dapat mengatasi cabaran ini dengan menyediakan pembelajaran yang lebih visual, interaktif, dan menarik (Cai et al., 2019; Jafari et al., 2023). Aplikasi AR memungkinkan pengguna melihat dan berinteraksi dengan model matematik dalam tiga dimensi, meningkatkan pemahaman konsep melalui pembelajaran aktif dan praktis (Cai et al., 2021).

Pelajaran matematik merupakan elemen penting dalam pendidikan, namun banyak pelajar menghadapi kesulitan dalam memahaminya. Masalah utama yang dikaji termasuk kekurangan visualisasi konsep matematik dan penggunaan sumber rujukan yang tidak memadai (Atiqoh, 2019; Hidayat, 2019). Penyelidikan menunjukkan keberkesanan penggunaan teknologi AR dalam meningkatkan pemahaman matematik, terutama dalam topik geometri (Shing Kit, C., & Mahmud, M. (2023). Namun, penggunaan AR dalam pendidikan matematik di Malaysia masih terhad (Rohendi et al., 2020).

Kajian ini bertujuan untuk merekabentuk dan membangunkan aplikasi AR untuk pembelajaran geometri 3D di kalangan pelajar Tingkatan 2 serta menilai minat mereka terhadap aplikasi tersebut. Dengan menyediakan aplikasi AR yang sesuai, diharapkan pelajar dapat lebih mudah memahami konsep matematik, khususnya geometri 3D, dan meningkatkan minat mereka dalam pembelajaran matematik. Ini akan membantu meningkatkan prestasi matematik pelajar secara keseluruhan di Malaysia.



KAJIAN LITERATUR

Kepentingan Pendidikan Matematik dalam Kehidupan

Menurut Ravi et al. (2021), integrasi STEM dalam pendidikan matematik merupakan agenda penting berdasarkan Pelan Pembangunan Pendidikan Malaysia (2013-2025). Integrasi ini membantu meningkatkan imaginasi pelajar dan kemampuan dalam menyelesaikan tantangan dengan aplikasi pengetahuan matematik dan pemikiran saintifik (Abdullah et al., 2018). Matematik memainkan peranan penting dalam mengembangkan kemampuan kognitif seperti pemikiran logis, penyelesaian masalah, analisis dan pemodelan yang esensial dalam berbagai bidang kehidupan dan profesional seperti sains, teknologi, kejuruteraan, ekonomi, dan perniagaan. Pendidikan matematik yang baik juga mendukung literasi teknologi dengan memahami konsep teknologi moden seperti kecerdasan buatan, analisis data, dan algoritma. Selain itu, pendidikan matematik membantu dalam pengembangan kemahiran hidup sehari-hari seperti numerasi, pemahaman statistik, pengelolaan kewangan dan pemecahan masalah praktis.

Cabaran dalam Pengajaran dan Pembelajaran Matematik

Pelajar sering kali menganggap matematik sebagai sesuatu yang sukar dan rumit yang menyebabkan kekurangan keyakinan diri dan hilang minat dalam subjek tersebut. Guru menghadapi cabaran utama seperti kesulitan dalam memahami penyelesaian masalah berbentuk ayat, konsep pengetahuan asas yang terhad, dan pengiraan yang tidak tepat (Yoong et al., 2021). Strategi pengajaran yang efektif termasuk mencipta persekitaran pembelajaran yang positif, menggunakan contoh relevan dan memberikan pengalaman praktis untuk membantu pelajar mengaitkan konsep matematik dengan dunia nyata. Penting untuk menyediakan sokongan tambahan kepada pelajar yang memerlukan serta mencabar pelajar yang lebih maju dengan sewajarnya. Penggunaan alat teknologi yang sesuai dan berkesan juga penting dalam pengajaran matematik. Penilaian yang holistik dan beragam diperlukan untuk menggambarkan pemahaman dan perkembangan pelajar. Kerjasama antara guru, pelajar, masyarakat dan sektor pendidikan penting untuk mencipta pengalaman pembelajaran matematik yang bermakna dan efektif.

Reka Bentuk Pembelajaran dalam Pendidikan

Reka bentuk pengajaran (ID) adalah proses sistematik dalam mencipta bahan sumber dan pengalaman pengajaran yang efektif dan menarik untuk memfasilitasi pembelajaran dan mencapai matlamat pendidikan tertentu. Ia melibatkan analisis teliti keperluan pembelajaran, reka bentuk dan pembangunan bahan pengajaran, serta penilaian keberkesannya. ID didefinisikan sebagai sains dalam mencipta amalan pengajaran yang spesifik, melibatkan penilaian, pengembangan, dan penyelenggaraan suasana pembelajaran yang kondusif bagi sesi pembelajaran. Matlamat utama reka bentuk pengajaran adalah untuk meningkatkan pengalaman pembelajaran dan mengoptimumkan hasil pelajar. Ia boleh digunakan dalam pelbagai konteks pendidikan, termasuk sekolah, universiti, latihan korporat, kursus dalam talian dan persekitaran pembelajaran tidak formal.

Reka Bentuk Pengajaran menggunakan model ADDIE

Model ADDIE adalah kerangka reka bentuk pengajaran yang melibatkan lima fasa: Fasa Analisis, Fasa Reka Bentuk, Fasa Pembangunan, Fasa Pelaksanaan dan Fasa Penilaian. Fasa



Analisis melibatkan pengumpulan maklumat tentang keperluan pembelajaran dan khalayak sasaran. Fasa Reka Bentuk menggunakan maklumat dari fasa Analisis untuk merancang pengajaran dan bahan pembelajaran. Fasa Pembangunan melibatkan penciptaan bahan pembelajaran berdasarkan reka bentuk. Fasa Pelaksanaan adalah apabila bahan pengajaran disampaikan kepada pelajar, dan fasa Penilaian melibatkan menilai keberkesanan pengajaran dan pencapaian hasil pembelajaran.

i. Analisis

Fasa analisis melibatkan pengumpulan dan menganalisis maklumat tentang keperluan pembelajaran, khalayak sasaran dan konteks pembelajaran. Matlamatnya adalah untuk mengenal pasti hasil pembelajaran dan keperluan khusus yang akan membimbing reka bentuk dan pembangunan pengajaran.

ii. Reka bentuk

Pada fasa reka bentuk, pereka bentuk pengajaran menggunakan maklumat yang dikumpul dalam fasa analisis untuk membuat rancangan pengajaran dan mereka bentuk bahan pembelajaran. Ini termasuk menentukan strategi pengajaran, memilih media dan teknologi yang sesuai, serta menyusun kandungan dengan cara yang logik dan berstruktur.

iii. Pembangunan

Fasa pembangunan adalah di mana penciptaan sebenar bahan pengajaran berlaku berdasarkan reka bentuk yang telah dibuat. Pereka bentuk pengajaran mencipta sumber pembelajaran seperti pembentangan, modul e-pembelajaran, video, aktiviti interaktif, atau penilaian. Kerjasama dengan pakar subjek dan pihak berkepentingan lain sering terlibat dalam fasa ini.

iv. Pelaksanaan:

Fasa pelaksanaan adalah apabila bahan pengajaran disampaikan kepada pelajar menggunakan pelbagai kaedah seperti arahan bersemuka, platform pembelajaran dalam talian, atau pendekatan pembelajaran campuran. Pengajar membimbing pelajar melalui bahan pengajaran dan memberikan sokongan serta bimbingan yang diperlukan.

v. Penilaian

Fasa penilaian melibatkan penilaian keberkesanan bahan pengajaran dan pencapaian hasil pembelajaran. Maklum balas dari pelajar, pengajar, dan pihak berkepentingan lain dikumpul untuk mengenal pasti kekuatan dan bidang untuk penambahbaikan dalam reka bentuk pengajaran.

Teknologi Pembelajaran Digital dalam Pendidikan

Teknologi Pembelajaran Digital merujuk kepada penggunaan alat dan aplikasi digital dalam pendidikan untuk meningkatkan pengalaman pembelajaran dan keberkesanan pengajaran. Ia memungkinkan akses pembelajaran secara fleksibel dan menawarkan pelbagai aplikasi seperti Sistem Pengurusan Pembelajaran (LMS), Aplikasi Mudah Alih, Multimedia Pembelajaran, Persidangan Video dan Webinar, serta Simulasi dan Permainan Pendidikan. Teknologi ini telah mengubah cara pembelajaran dan pengajaran dilakukan, menjadikannya lebih inklusif, menarik, dan berkesan (Danuri et al., 2020; Abd Gani, 2015).

i. Aplikasi Teknologi Pengajaran Digital

Penggunaan aplikasi teknologi digital dalam pendidikan memberikan kesan positif kepada pelajar. Terdapat pelbagai aplikasi dan platform yang berkembang, seperti Sistem Pengurusan



Pembelajaran (LMS), Aplikasi Mudah Alih, Multimedia Pembelajaran, Persidangan Video dan Webinar, serta Simulasi dan Permainan Pendidikan. Teknologi ini telah mengubah cara pembelajaran dan pengajaran dilakukan, menjadikannya lebih inklusif, menarik, dan berkesan.

ii. Pembelajaran Maya atau Pembelajaran Atas Talian

Pembelajaran maya, juga dikenali sebagai e-pembelajaran atau pembelajaran jarak jauh, menggunakan teknologi digital untuk menyampaikan kandungan pembelajaran, berinteraksi antara pengajar dan pelajar, serta menyokong aktiviti pembelajaran maya. Ia memberikan kebolehcapaian dan fleksibiliti, menggunakan platform pembelajaran dalam talian, dan melibatkan penggunaan teknologi sokongan seperti persidangan video dan perisian simulasi.

iii. Penilaian Kajian Berkaitan Teknologi dalam Pendidikan

Penggunaan aplikasi digital dalam pendidikan dapat dinilai keberkesanannya melalui beberapa pendekatan penilaian. Ini termasuk pemerhatian pelajar semasa menggunakan aplikasi, tinjauan pelajar tentang pengalaman mereka, ulasan dan maklum balas pelajar, serta penilaian hasil pembelajaran dengan mengukur kemajuan pelajar sebelum dan selepas menggunakan aplikasi. Penilaian ini membantu memahami impak teknologi digital dalam meningkatkan pembelajaran pelajar.

Penerapan *Augmented Reality* dalam Pembelajaran Digital dan Pendidikan Matematik

Augmented Reality (AR) telah menjadi subjek penting dalam pembelajaran digital, memberikan pengalaman yang interaktif dan melibatkan elemen-elemen digital dalam konteks dunia nyata. Dalam konteks pembelajaran digital, AR dapat meningkatkan penglibatan pelajar melalui permainan dan alat bantu interaktif, seperti yang didapati dalam kajian oleh Costa et al. (2020) dan Bautista (2022). AR juga menawarkan peluang yang besar dalam meningkatkan pembelajaran matematik, khususnya geometri 3D. Dengan memanfaatkan visualisasi 3D interaktif, AR membolehkan pelajar untuk memahami konsep-konsep abstrak dengan lebih baik. Pembelajaran kolaboratif menggunakan AR juga meningkatkan interaksi sosial di kalangan pelajar, memperkaya pengalaman pembelajaran.

METODOLOGI

Bentuk Kajian

Tahap minat serta penerimaan pelajar dengan penggunaan *Augmented Reality* (AR) dalam pembelajaran diukur melalui kaedah tinjauan. Edaran borang soal selidik diberikan hanya kepada kumpulan rawatan iaitu yang menggunakan *Augmented Reality* (AR) semasa sesi pengajaran dan pembelajaran. Instrumen kajian merujuk kepada Skala Likert lima mata. (1- Sangat Tidak Setuju (STS), 2- Tidak Setuju (TS), 3- Kurang Setuju (KS), 4- Setuju (S), 5- Sangat Setuju (SS)). Ketekalan pernyataannya menjadi ukuran skala ini dipilih dan dapat diukur dengan baik. Pekali alpha Cronbach dianalisa bagi melihat kebolehpercayaan dan kesahan item instrumen kajian.

Kajian ini mengikuti Model ADDIE dalam pembangunan aplikasi *Augmented Reality* (AR) untuk membantu murid Tingkatan 2 menguasai topik Bentuk Geometri 3D dalam



matapelajaran Matematik. Tahap Analisis dilakukan untuk mengenal pasti masalah dan objektif kajian, termasuk kajian rintis terhadap kesediaan pengguna terhadap teknologi *Augmented Reality*. Fasa Rekabentuk merancang aplikasi melalui jalan cerita, papan cerita, dan reka bentuk antara muka yang sesuai dengan sasaran pengguna. Rajah 1.2 adalah adaptasi dari kajian Abdul Rahman et al. (2020) merupakan carta alir proses yang akan berlaku dalam aplikasi yang akan dibangunkan dalam pembangunan modul. Dalam fasa ini, aplikasi dikembangkan menggunakan perisian seperti Blender, Unity 3D, dan Vuforia untuk menghasilkan marker dan *Augmented Reality*. Tambahan pula, beberapa aplikasi lain seperti Canva, Adobe Photoshop, dan pembuat video juga digunakan untuk menyokong pembangunan. Unity 3D adalah perisian enjin 3D lintas platform yang mudah digunakan, memungkinkan pengembang untuk membuat permainan dan aplikasi 3D untuk pelbagai platform termasuk telefon mudah alih, desktop, web, dan konsol permainan video. Fasa Pelaksanaan melibatkan ujian keberkesanan produk dengan melibatkan sampel 27 murid Tingkatan 2. Fasa Penilaian menggunakan Model Penilaian Kepenggunaan TUP untuk menilai keberkesanan aplikasi *Augmented Reality*.

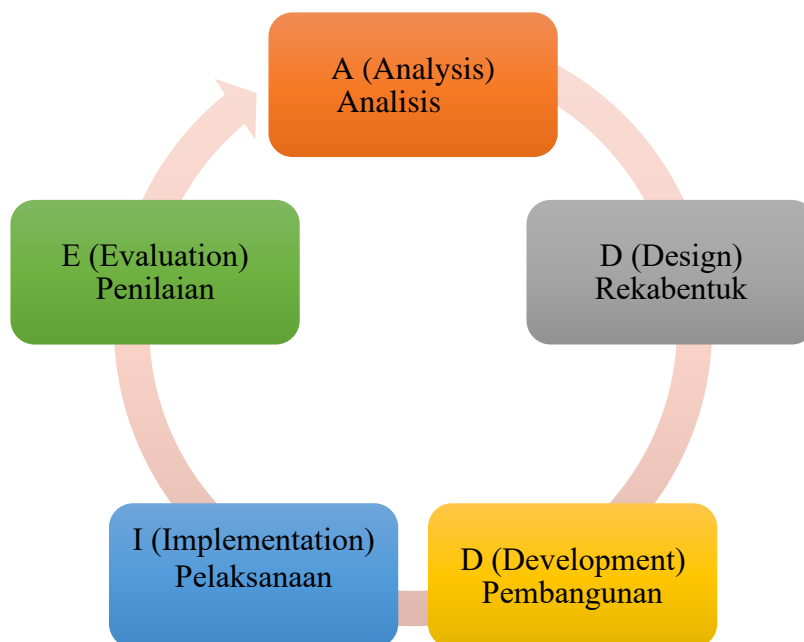

Rajah 1.1: Aliran kerja berdasarkan model ADDIE

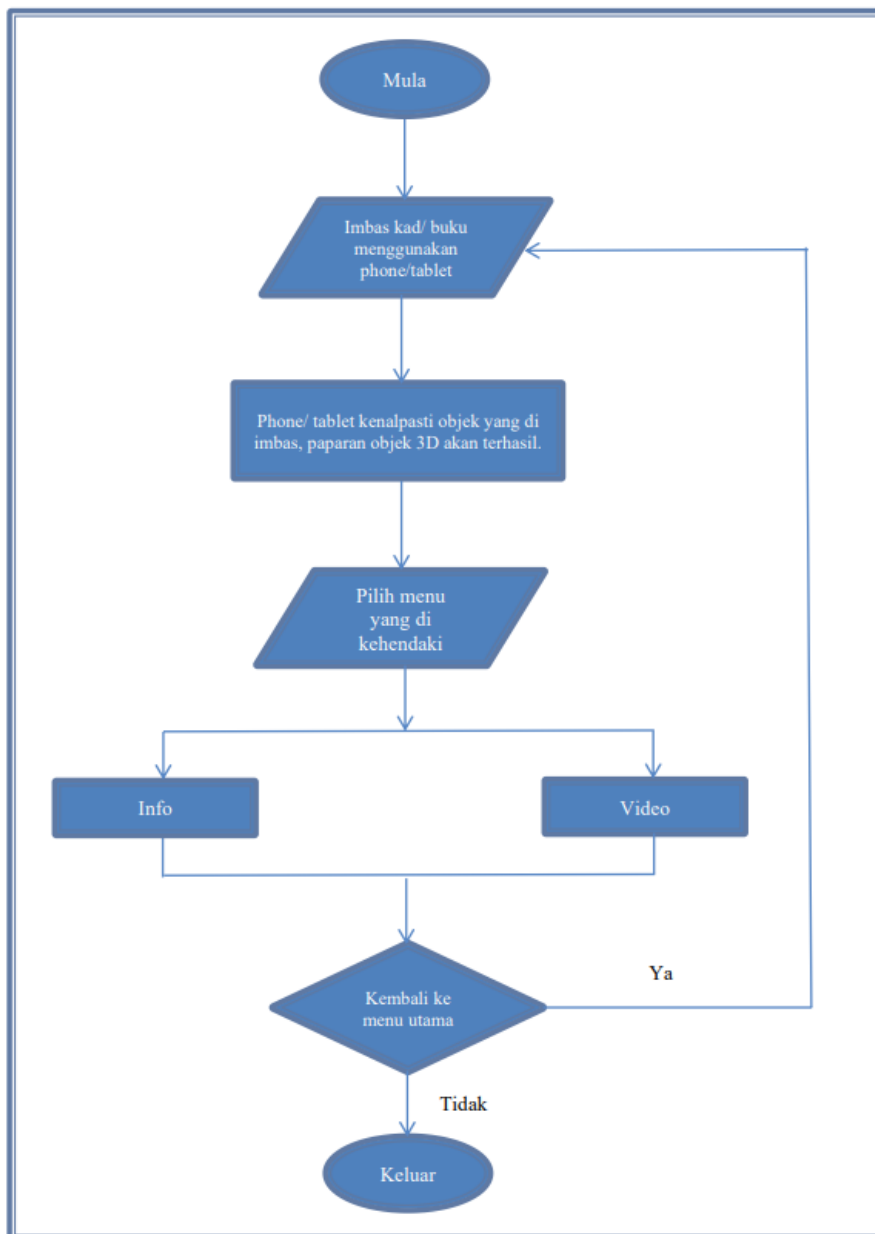

Rajah 1.2: Carta Alir Bagi Proses yang akan berlaku dalam Aplikasi

Fasa penilaian dalam model ADDIE merupakan peringkat kritikal yang menilai keberkesanan keseluruhan reka bentuk dan pelaksanaan pengajaran. Soal selidik memainkan peranan penting dalam fasa ini dengan menyediakan cara yang sistematik dan tersusun untuk mengumpul maklum balas daripada responden. Kajian ini melibatkan 27 orang pelajar tingkatan 2 dengan tujuan menguji aplikasi *Augmented Reality* (AR) dalam topik geometri bentuk 3D.

Sebanyak 27 orang responden dipilih untuk memberi maklum balas menggunakan borang Soal Selidik yang terdiri dari 2 bahagian: bahagian A berkaitan dengan demografi dan bahagian B berkaitan dengan aspek penggunaan *Augmented Reality* (AR). Borang soal selidik dibangunkan dengan panduan rujukan Arnold Lund melalui konsep USE (*Usefulness, Satisfaction, and Ease of Use*) dengan menggunakan skala Likert 5 mata iaitu Sangat Tidak Setuju, Tidak Setuju, Tidak Pasti, Setuju, dan Sangat Setuju. Rujukan ini penting untuk memastikan kebolehpercayaan dan kesahan yang tinggi terhadap borang soalan selidik ini.



Analisis kuantitatif dilakukan terhadap data dari soal selidik menggunakan perisian SPSS versi 16.0. Proses pengumpulan data dan analisis data direncanakan untuk menjawab persoalan kajian yang berkaitan dengan keberkesanan penggunaan aplikasi *Augmented Reality* dalam pembelajaran geometri bentuk 3D.

DAPATAN KAJIAN

Analisis Demografi Responden (Bahagian A)

Berdasarkan kajian yang dijalankan, seramai 27 responden terdiri daripada pelajar-pelajar tingkatan 2 telah menjawab soal selidik melalui borang soal selidik. Merujuk analisis maklumat demografi responden, penyelidik hanya melihat kepada jantina, lokaliti tempat tinggal responden dan tinjauan pengalaman terhadap *Augmented Reality* (AR).

Berdasarkan demografi responden, didapati 55.6% iaitu 15 orang responden merupakan responden perempuan manakala 44.4% dengan seramai 12 orang merupakan responden lelaki. Ini menunjukkan bilangan responden perempuan melebihi responden lelaki. Taburan lokaliti tempat tinggal daripada keseluruhan 27 orang responden menunjukkan terdapat 10 responden terdiri daripada lokaliti tempat tinggal kategori Dalam Bandar (DB) iaitu 37.04%, manakala 17 responden terdiri daripada lokaliti tempat tinggal kategori Luar Bandar (LB) sebanyak 62.96%. Seterusnya, taburan pengalaman responden menggunakan AR dalam kalangan 27 orang responden menunjukkan hanya 5 responden menyatakan 'Ya' (18.5%) manakala majoriti responden seramai 22 orang iaitu 81.5% menyatakan 'Tidak' yang membawa maksud tiada pengalaman berkaitan penggunaan AR secara umum.

Analisis Bahagian B: Aspek berkaitan penggunaan *Augmented Reality* (AR)

Analisis Aspek Minat Responden terhadap mata pelajaran Matematik menggunakan aplikasi Augmented Reality (AR)

Analisis menunjukkan minat pelajar terhadap mata pelajaran melalui penggunaan aplikasi *Augmented Reality* (AR) adalah tinggi, min = 4.43. Ini menunjukkan responden bersetuju bahawa aplikasi *Augmented Reality* (AR) telah menarik minat mereka untuk belajar Matematik dengan lebih baik. Dapatan ini disokong oleh Cai et. Al (2020) yang menyatakan *Augmented Reality* (AR) membantu kefahaman dalam pembelajaran topik kebarangkalian dan meningkatkan minat belajar yang positif. Menurut Shubham et al., (2018), teknologi *Augmented Reality* (AR) turut membantu pelajar dalam memberi inspirasi dalam belajar dan menjadikan pengalaman belajar lebih menyeronokkan.

Justeru, rumusan laporan ini dapat menggambarkan bahawa penerapan teknologi *Augmented Reality* (AR) dalam pembelajaran Matematik mendapat respon yang positif dalam kalangan pelajar. Situasi ini boleh menjadi asas untuk mempertimbangkan pembangunan dan penyepaduan teknologi *Augmented Reality* (AR) selanjutnya dalam konteks pendidikan dalam meningkatkan minat dan pemahaman pelajar terhadap mata pelajaran tertentu terutama mata pelajaran matematik.



Jadual 1.2: Aspek Minat Pelajar Menggunakan aplikasi *Augmented Reality* (AR) dalam proses pembelajaran dan pengajaran Matematik

Item	Respon					Min
	1	2	3	4	5	
B1. Saya suka belajar menggunakan aplikasi AR.	-	-	1	10	16	4.56
B2. Saya berasa seronok apabila menggunakan aplikasi AR.	-	-		11	16	4.59
B3. Saya berasa mudah mempelajari Matematik melalui aplikasi AR.	-	-	5	14	8	4.11
B4. Saya seronok menggunakan aplikasi AR kerana mudah di akses di mana sahaja.	-	-	3	10	14	4.41
B5. Saya seronok menggunakan fungsi dalam aplikasi AR untuk belajar Matematik.	-	-	2	14	11	4.33
B6. Saya berminat menggunakan aplikasi AR untuk memahami konsep Matematik.	-	-	2	13	12	4.37
B7. Saya tahu fungsi aplikasi AR dalam pembelajaran hari ini.	-	-	3	12	12	4.33
B8. Saya suka dengan paparan aplikasi AR.	-	-	1	10	16	4.56
B9. Saya suka menggunakan aplikasi AR bersama rakan-rakan.	-	-	2	6	19	4.63
B10. Saya suka penerangan informasi dan grafik aplikasi AR	-	-	1	13	13	4.44
Keseluruhan				4.43		

Analisis Aspek Tahap Pengetahuan Responden terhadap mata pelajaran Matematik menggunakan aplikasi Augmented Reality (AR)

Analisis mendapati pengetahuan pelajar dalam penggunaan aplikasi *Augmented Reality* juga tinggi, min = 4.22. Ini menunjukkan responden turut bersetuju bahawa penggunaan aplikasi AR boleh membantu pelajar memahami dan mempelajari pembelajaran mereka lebih berkesan dan lebih baik. Menurut Ahmad & Junaidi (2022) melalui kajian merumuskan penggunaan aplikasi *Augmented Reality* berasaskan aktiviti permainan kad berjaya untuk meningkatkan kecekapan matematik pelajar. Kajian Chao & Chang (2018) menyokong dapatan dengan menunjukkan bahawa pelajar boleh menerima aplikasi pembelajaran Matematik AR yang dibangunkan oleh institut berkenaan dan ia juga boleh memulakan minat mereka untuk belajar. Keputusan sebelum dan selepas belajar menunjukkan bahawa kesan pembelajaran telah menunjukkan perubahan dengan ketara. Penggunaan aplikasi *Augmented Reality* (AR) dalam Pendidikan adalah seiring dengan trend yang lebih luas dalam teknologi Pendidikan di mana *Augmented Reality* (AR) telah menunjukkan kesan positif dalam mencipta pengalaman pembelajaran yang menarik dan interaktif, meningkatkan kefahaman serta minat pelajar dalam pelbagai mata pelajaran, termasuk



matematik.

Kesimpulannya, aplikasi pembelajaran Matematik *Augmented Reality* (AR) yang dibangunkan boleh memulakan minat mereka untuk belajar dengan mengukuhkan impak positif aplikasi *Augmented Reality* (AR) terhadap pengetahuan dan pengalaman pembelajaran pelajar. Maklumat ini boleh menjadi berharga untuk pendidik, penggubal dasar dan penyelidik yang berminat untuk memanfaatkan teknologi untuk meningkatkan hasil pendidikan, khususnya dalam bidang matematik.

Jadual 1.3: Aspek Tahap Pengetahuan pelajar semasa penggunaan aplikasi *Augmented Reality*

Item		Respon					Min
		1	2	3	4	5	
B11.	Saya tahu mengakses AR aplikasi secara atas talian (<i>online</i>).	-	-	4	9	14	4.37
B12.	Saya tahu menggunakan aplikasi AR meningkatkan penguasaan Matematik saya.	-	-	3	15	9	4.22
B13.	Penggunaan AR yang dibangunkan mudah dan sesuai semasa pembelajaran Matematik	-	-	3	14	10	4.26
B14.	Saya dapat menggunakan fungsi aplikasi AR bagi meningkatkan pengetahuan.	-	-	2	11	14	4.44
B15.	Penggunaan AR dapat meningkatkan kemahiran saya menggunakan komputer.	-	-	1	10	16	4.56
B16.	Penggunaan AR dapat meningkatkan pengetahuan saya menggunakan internet dalam mencari maklumat.	-	-	1	10	16	4.56
B17.	Saya berkongsi pengetahuan penggunaan aplikasi AR kepada rakan-rakan.	-	-	4	14	9	4.19
B18.	Saya tahu mencari maklumat menggunakan aplikasi AR	-	-	5	10	12	4.26
B19.	Saya tahu mendaftar masuk kod imbasan semasa menggunakan aplikasi AR	-	-	7	6	14	4.26
B20.	Saya tahu membina aplikasi AR saya sendiri.	4	2	11	8	2	3.07
Keseluruhan		4.22					

Analisis hubungan aspek tahap kepuasan responden terhadap aspek minat dan aspek pengetahuan menggunakan Augmented Reality (AR).

Analisis korelasi Pearson yang menghubungkan aspek tahap kepuasan responden terhadap



aspek minat dan aspek pengetahuan menggunakan *Augmented Reality* (AR) menunjukkan terdapatnya korelasi positif yang tinggi antara aspek minat dengan aspek pengetahuan ($r=.730, p<0.05$).

Kesimpulan yang diperoleh daripada korelasi ini menyokong hipotesis nol, menunjukkan bahawa terdapat pengaruh aspek minat dan pengetahuan dalam aplikasi *Augmented Reality* (AR) yang menyokong pemahaman pelajar tentang kandungan topik semasa pembelajaran matematik. Ini menunjukkan bahawa memupuk minat, selain meningkatkan pengetahuan, memainkan peranan penting dalam memanfaatkan teknologi *Augmented Reality* (AR) untuk pengalaman pembelajaran yang berkesan.

Menurut kajian oleh Talan et. al. (2022) melalui dapatan temu bual dengan pelajar mendedahkan bahawa aplikasi *Augmented Reality* (AR) digunakan dalam kursus kajian beliau adalah menarik telah mendorong kepada peningkatan kepada minat, keinginan, dan motivasi dalam kelas, dan akhirnya meningkatkan persekitaran pembelajaran yang berkesan serta memberi impak kepada tahap pencapaian pelajar.

Jadual 1.5: Analisis Korelasi

	Aspek Minat	Aspek Pengetahuan
Aspek Minat	1	0.730
Aspek Pengetahuan	0.730	1

** Korelasi adalah signifikan pada aras 0.05 (2 tailed)

KESIMPULAN

Dapatan kajian menunjukkan bahawa penggunaan aplikasi berdasarkan *Augmented Reality* (AR) telah membantu meningkatkan minat dan pengetahuan pelajar terhadap mata pelajaran Matematik. Ini secara langsung menyokong pandangan yang menyatakan bahawa dengan meningkatkan motivasi dan minat pelajar, kefahaman terhadap pembelajaran Matematik juga meningkat. Kajian Abdul Hanid et al. (2022) melalui penggunaan teknologi AR dalam kalangan pelajar menunjukkan pencapaian yang lebih tinggi daripada kaedah konvensional, sementara Mohd Fadzil dan Mohd Nihra (2019) menegaskan bahawa penggunaan teknologi aplikasi dalam pembelajaran memberikan kebaikan dalam meningkatkan kualiti pembelajaran.

Trend utama dalam pendidikan hari ini menunjukkan penekanan yang semakin besar kepada penggunaan teknologi dalam pembelajaran. Penggunaan peranti elektronik dan teknologi pendidikan telah mengubah cara guru mengajar dan pelajar belajar. Ini termasuk penggunaan e-pembelajaran, video pembelajaran, dan platform pembelajaran dalam talian yang memberikan ruang akses yang lebih luas kepada sumber pembelajaran dan mendukung pembelajaran bebas. Pembelajaran Berasaskan Projek (PBP) juga semakin popular, menekankan pembelajaran aktif, kolaboratif, dan kemahiran praktikal. Dengan perubahan aliran pendidikan ini, penggunaan teknologi seperti *Augmented Reality* (AR) melalui pendekatan pembelajaran seperti Pembelajaran Berasaskan Projek (PBP) telah membantu meningkatkan pengalaman pembelajaran pelajar. Ini berpotensi untuk meningkatkan motivasi, minat, dan kefahaman pelajar terhadap subjek Matematik dan mempersiapkan mereka untuk menghadapi tuntutan dunia yang semakin kompleks. Oleh itu, pengintegrasian teknologi serta pendekatan pembelajaran yang inovatif adalah penting untuk memastikan pendidikan yang lebih berkualiti dan relevan untuk masa depan.



RUJUKAN

- Abd Gani, M. I. 2015. *MODEL ADDIE DALAM PROSES REKA BENTUK MODUL PENGAJARAN: BAHASA ARAB TUJUAN KHAS DI UNIVERSITI SAINS ISLA MALAYSIA SEBAGAI CONTOH*.
- Abdul Rahman, K., Othman, H., Aziz, S. & Nurkaliza, K. 2020. *Analisis Rekabentuk Aplikasi "Augmented Reality" bagi pembelajaran Komponen Sistem Unit Komputer*.
- Abdullah, A., Hamzah, M. H. & Ismail, N. 2018. Mathematics Curriculum Framework for Early Childhood Education Based on Science, Technology, Engineering and Mathematics (STEM). *International Electronic Journal of Mathematics Education* 14(15-31).
- Ahmad, N. I. & Junaini, S. 2022. PrismAR: A Mobile Augmented Reality Mathematics Card Game for Learning Prism. *International Journal of Computing and Digital Systems* 11(217-225).
- Atiqoh, K. 2019. ANALISIS KESALAHAN SISWA DALAM MENYELESAIKAN SOAL PEMECAHAN MASALAH PADA MATERI POKOK BANGUN RUANG SISI DATAR. *ALGORITMA Journal of Mathematics Education* 1(
- Azlan, N. & Abdullah, M. 2017. Komunikasi matematik : Penyelesaian masalah dalam pengajaran dan pembelajaran matematik. *Jurnal Pendidikan Sains Dan Matematik Malaysia* 7(16-31).
- Bautista, J. 2022. Haynayan AR: An Augmented Reality-Based Lesson for the Improvement of Learning Achievement in Cell Biology for the STEM Curriculum. 1(
- Cai, S., Liu, E., Shen, Y., Liu, C., Li, S., & Shen, Y. (2020). Probability learning in mathematics using augmented reality: impact on student's learning gains and attitudes. *Interactive Learning Environments*, 28(5), 560–573. <https://doi.org/10.1080/10494820.2019.1696839>
- Cai, S., Yang, Y. & Liang, J.-C. 2019. Tablet-based AR technology: Impacts on students' conceptions and approaches to learning mathematics according to their self-efficacy. *British Journal of Educational Technology* 50(248-263).
- Chao, W. H., & Chang, R. C. (2018). Using Augmented Reality to Enhance and Engage Students in Learning Mathematics. *Advances in Social Sciences Research Journal*, 5(12) 455-464.
- Costa, M., Manso, A. & Patrício, J. 2020. *Design of a Mobile Augmented Reality Platform with Game-Based Learning Purposes*. 11.
- Danuri, M., Informatika, M., Teknologi, J. & Semarang, C. 2020. PERKEMBANGAN DAN TRANSFORMASI TEKNOLOGI DIGITAL. 15(116-123).
- Eboy, O., Ibrahim, D. & Radzi, M. 2022. Penentuan Corak Hubungan Golongan Bekerja Dari Rumah Semasa Perintah Kawalan Pergerakan (PKP) COVID-19 Menggunakan GIS. 7(129-140).
- Hanid, M. F., Mohamad Said, M. N. H. B., Yahaya, N. & Abdullah, Z. 2022. The Elements of Computational Thinking in Learning Geometry by Using Augmented Reality Application. *International Journal of Interactive Mobile Technologies (iJIM)* 16(28-41).
- Hidayat, T. 2019. Analisis Kesalahan Konsep Dan Kesalahan Prosedur Dalam Menyelesaikan Soal Bangun Ruang Sisi Datar. *Jurnal Equation: Teori dan Penelitian Pendidikan Matematika* 2(105).



- Hui, E. & Rosli, R. 2021. Kebimbangan dan Efikasi Kendiri Terhadap Pembelajaran Matematik dalam kalangan Pelajar Tingkatan Empat. *Malaysian Journal of Social Sciences and Humanities (MJSSH)* 6(41-53).
- Iwit, P., Marhadi, S. & Hartono, H. 2022. Augmented reality-based flat-sided building cards to improve students' understanding of mathematical concepts. *International Journal of Trends in Mathematics Education Research* 5(1): 34-37.
- Jafari, E., Talebi-Abatari, Z., Zadeh, M. R. & Firoozabad, V. S. 2023. THE EFFECT OF AUGMENTED REALITY ON THE LEVEL OF ATTENTION OF FIRST ELEMENTARY STUDENTS IN THE COURSE OF EXPERIMENTAL SCIENCES. *Journal of Educators Online* 20(3): 1-15.
- Mohd Fadzil, A. H., & Mohd Nihra Haruzuan, M. S. (2019). Mobile Application for G-Suite Based on Multimedia Learning Cognitive Theory. *Innovative Teaching and Learning Journal*, 3(1), 55–60.
- Mohd Shafian, S., Chew, C. M. & Munirah, G. 2021. Impak pendekatan konkrit-gambar abstrak berbantuan kajian pengajaran kolaboratif terhadap profisiensi murid Tahun Empat dalam topik luas.
- Ravi, D. & Mahmud, M. S. 2021. Pengintegrasian Stem Dalam Pengajaran Matematik Di Sekolah Rendah: Tinjauan Literatur (The Integration of Stems in the Teaching of Mathematics in Primary Schools: A Literature Review). 3(179-188).
- Rohendi, D. & Wihardi, Y. 2020. Learning Three-Dimensional Shapes in Geometry Using Mobile-Based Augmented Reality. *International Journal of Interactive Mobile Technologies (iJIM)* 14(48).
- Shing Kit, C., & Mahmud, M. (2023). Keberkesanan Pembelajaran Berasaskan Perisian Terhadap Penguasaan Geometri dalam kalangan Murid Tahun Enam: Sebuah Tinjauan Literatur. *Malaysian Journal of Social Sciences and Humanities (MJSSH)*, 8(1), e002037. <https://doi.org/10.47405/mjssh.v8i1.2037>
- Shubham, Charan, P., & Murty, L. S. (2018). Organizational adoption of sustainable manufacturing practices in India: integrating institutional theory and corporate environmental responsibility. *International Journal of Sustainable Development and World Ecology*, 25(1), 23–34. <https://doi.org/10.1080/13504509.2016.1258373>
- Talan, T., Yilmaz, Z.A., & Batdi, V. (2022). The effects of augmented reality applications on secondary students' academic achievement in science course. *Journal of Education in Science, Environment and Health (JESEH)*, 8(4), 332-346. <https://doi.org/10.21891/jeseh.1193695>
- World Health Organization (WHO). (2020). Coronavirus disease (COVID-19) pandemic. <https://www.who.int/emergencies/diseases/novel-coronavirus-2019#>
- Yoong, Y. Q. & Mohamad Nasri, N. 2021. Analisis Kesilapan Newman Dalam Penyelesaian Masalah Matematik Berayat. *Jurnal Dunia Pendidikan* 3): 373-380% V 373.



077-054

TO IMPROVING THE KNOWLEDGE MASTERY ABOUT PRINCIPLES OF EDUCATION OF UNDERGRADUATE STUDENTS IN THE EDUCATION COURSE THROUGH THE IMPLEMENTATION OF OBE

ABSTRACT

This study aims to enhance the knowledge mastery of third-year undergraduate students in the Education course at Dongguan City University by implementing Outcome-Based Education (OBE) principles. Using action research methodology, the study explores effective instructional approaches by integrating various teaching methods such as task-based teaching, project-based learning, problem-solving teaching, flipped classroom, inquiry-based learning, and case-based teaching. Throughout the research process, assessments and reflections on teaching effectiveness were conducted via pre-tests, Cycle 1, and Cycle 2 tests and surveys. The results indicate varying outcomes among the instructional cycles. While the adoption of OBE principles and diverse teaching methods led to a significant improvement in students' academic performance and satisfaction from pre-test to Cycle 2, there were notable differences in the comparison between cycles. Specifically, the comparison between pre-test and Cycle 2 showed a significant enhancement in both academic performance and satisfaction levels. However, the comparison between pre-test and Cycle 1 revealed a potential lack of significant improvement, suggesting the need for further instructional refinement. Despite the overall positive trend, some students expressed a moderate level of satisfaction with the instructional activities, signaling the necessity for continuous enhancement in teaching strategies and methods. In conclusion, this study offers valuable insights into the effectiveness of OBE principles and diverse teaching methods in enhancing educational outcomes. It provides a framework for educational practice, contributing to the improvement of education courses and student satisfaction.

Keywords: Knowledge Mastery, Education Course, OBE,AR.

1. INTRODUCTION

Education serves as the cornerstone of societal development, with the quality and effectiveness of education courses directly influencing the competence and professionalism of future educators. To enhance the teaching quality of the Education course for third-year undergraduate students at Dongguan City University, this study aims to explore and implement the concept of Outcome-Based Education (OBE) through action research methods to improve students' mastery of educational knowledge.

General Background

In recent years, there has been an increasing call for educational reform in the education sector. Traditional teaching models face challenges and require a greater emphasis on fostering students' practical skills and problem-solving abilities. Against this backdrop, Outcome-Based Education (OBE), as an education philosophy centered around learning outcomes, has garnered widespread attention.



Problem Statement

However, challenges persist in the Education course at Dongguan City University. Students often encounter difficulties in grasping the principles of education, indicating the necessity for innovative teaching approaches. Traditional teaching methods may not fully cater to the diverse learning needs of students, leaving room for improvement in their mastery of knowledge and practical application abilities. Therefore, this study aims to address these challenges by exploring the implementation of Outcome-Based Education (OBE) principles. OBE offers a framework that focuses on holistic learning outcomes, providing opportunities for students to develop a deeper understanding of educational knowledge and cultivate practical skills essential for their future careers in the field of education.

Research Gap

Although the concept of Outcome-Based Education (OBE) has garnered significant attention and research internationally, there remains a gap in understanding its specific implementation within the context of Dongguan City University. Previous studies have explored OBE theory and practice extensively, highlighting its benefits in promoting student-centered learning and holistic development. However, there is a lack of research focusing on the integration of OBE principles into the teaching practices at Dongguan City University. Consequently, this study aims to bridge this research gap by examining how OBE principles can be effectively integrated into the university's teaching practices to enhance the effectiveness of the Education course. By building upon previous research on OBE theory and practice, this study seeks to provide valuable insights into the unique challenges and opportunities associated with implementing OBE at Dongguan City University, thus contributing to the existing body of knowledge in the field.

Research Problems and Objectives

Dongguan City University primary education students in the third year of the education programme in the knowledge of the principles of education have certain problems, the main problems are not solid knowledge mastery, learning test scores are relatively low, the satisfaction is not high, and the interest in learning is not strong when the traditional teaching methods are used.

By building upon previous research on OBE theory and practice, this study seeks to provide valuable insights into the unique challenges and opportunities associated with implementing OBE at Dongguan City University.

Objectives: To increase the knowledge of pedagogical principles by the development and implementation of OBE teaching methodology in education courses at Dongguan City University

2. LITERATURE REVIEW

National Policy Support

Educational reform and curriculum development are often guided and supported by national policies. In recent years, the Chinese Ministry of Education has introduced a series of policy measures for higher education reform, emphasizing the importance of teaching quality and the



cultivation of students' practical abilities. For instance, the Ministry of Education advocates exploring talent training models that are in line with national conditions and market demands, encouraging universities to focus on cultivating students' practical abilities and innovative spirit. These policies provide policy support and guidance for the implementation of Outcome-Based Education (OBE) and other educational reforms.

Joining the Washington Accord: China has joined the Washington Accord, an international engineering education accreditation system aimed at promoting the internationalization and standardization of engineering education. Joining this accord signifies that engineering education in China will pay more attention to cultivating students' practical abilities and problem-solving skills, providing policy support for educational reform.

Teacher Education Accreditation: In order to improve the quality of teacher education, the Chinese Ministry of Education conducts accreditation and evaluation of teacher education programs, requiring that trained teachers possess rich teaching experience and practical abilities. This measure helps to improve the level of teacher education and fundamentally enhance educational quality. OBE, as a student-centered educational philosophy, has been recognized and promoted by the Chinese Ministry of Education.

Theoretical Foundation

OBE, as a student-centered educational philosophy, has been widely researched and applied internationally. Its theoretical foundation mainly includes learning theories, cognitive psychology, and educational assessment theories. For example, Bloom's cognitive taxonomy theory proposes a hierarchical system of learning objectives, providing theoretical support for the design and assessment of learning outcomes. Additionally, extensive research indicates that by setting clear learning outcomes and promoting students to achieve these outcomes through various teaching activities and assessment methods, it is possible to effectively improve students' academic performance and practical abilities.

School Needs

As places of concrete practice, schools' needs have a significant impact on educational reform and curriculum design. Dongguan City University, as an undergraduate institution, needs its education courses to align with the school's educational positioning and students' actual needs. For example, Dongguan City University is facing the task of cultivating applied talents, thus requiring the design of education courses that meet market demands and enhance students' practical abilities.

In conclusion, national policy support, theoretical foundation, and school needs are important considerations guiding educational reform and curriculum design, and they are of great significance for implementing Outcome-Based Education (OBE) and other educational reforms. When conducting action research, it is essential to consider these three aspects comprehensively to ensure the effective implementation of educational reform and the improvement of curriculum design quality.

3. METHODOLOGY

Process of Action Research



Research methods

Research Objectives	Data Collection Method	Data Collection Tools	Data Analysis (Pre&Post)	Data Analysis Tools
1. Assessing the Impact of Teaching Activities on Students' Mastery of Knowledge.	Test	Education Knowledge Test	Comparison of Pre-test and Post-test Scores,	Descriptive Statistics
2. Understanding Students' Feedback and Perspectives on Teaching Activities.	Questionnaire	Questionnaire on Student Satisfaction, Feedback, etc.,	Analysis of Survey Results	Descriptive Statistics

Stage	HOW TO COLLECT DATA	WHAT TO MEASURE/EXPLORE	HOW TO MEASURE IMPROVEMENT (PRE & POST)	HOW TO REPORT THE IMPROVEMENT
Preparation Phase (Pre-test)	Administer a pre-test to students before implementing interventions.	Baseline knowledge and understanding of students.	Compare pre-test scores with post-test scores to assess improvement.	Report on the initial level of knowledge and understanding among students.
Cycle 1 Implementation (Task-Based Learning, Project-Based Learning, Problem-Based Learning)	Conduct tests and surveys after implementing instructional activities aligned with OBE principles.	Academic performance, satisfaction levels, and feedback from students.	Compare Cycle 1 test scores and survey results with pre-test data to measure progress.	Report on improvements observed in academic performance and satisfaction levels.
Cycle 2 Implementation (Flipped Classroom, Inquiry-Based Learning, Case-Based Teaching)	Continue to administer tests and surveys after making adjustments and improvements based on Cycle 1 findings.	Academic performance, satisfaction levels, and feedback from students post-intervention.	Compare Cycle 2 test scores and survey results with Cycle 1 data to assess further progress.	Report on additional improvements observed and adjustments made in Cycle 2.



Stage	HOW TO COLLECT DATA	WHAT TO MEASURE/EXPLORE	HOW TO MEASURE IMPROVEMENT (PRE & POST)	HOW TO REPORT THE IMPROVEMENT
Continuous Monitoring and Feedback	Gather ongoing feedback from students throughout the implementation process.	Student engagement, satisfaction levels, and progress.	Analyze continuous feedback and monitor trends to identify areas for further improvement.	Report on trends observed in student engagement, satisfaction, and progress.
Documentation and Reporting	Compile comprehensive reports detailing the entire implementation process, including data from pre-tests, intervention activities, and post-tests.	Effectiveness of interventions, improvements in student learning outcomes and satisfaction.	Present findings and insights to relevant stakeholders for informed decision-making.	Share reports detailing the effectiveness of the intervention and its impact.

4. FINDINGS: --4.1 PRE-TEST

4.1.1 Test

- Use traditional teaching methods without any intervention in teaching.
- Test students' understanding of the first unit and record their scores.
- 30 students participated in the test.

Findings:

Among them, 4 students failed, 20 passed, 6 were average, and none achieved a good or excellent score.

With a maximum score of 100, the lowest score was 56, the highest was 77, and the average score was 68.

Descriptive Analysis:

The average score of students is 68, which is close to the passing line, indicating that overall, the students' learning level is acceptable, but there is still room for improvement.

Most students (about 67%) achieved passing grades or higher in the test, but there is also a portion of students (about 33%) who did not meet the passing line, i.e., the knowledge, skills,



and attitudes they were expected to attain. In this test result, we can analyze that students' test scores reflect their failure to achieve the expected learning outcomes.

Therefore, it may be necessary to intervene in learning using OBE teaching methods.

Grade	Sample Size	Fail (0-59)	Pass (60-69)	Moderate (70-79)	Good (80-89)	Excellent (90-100)
Number	30	4	20	6	0	0

Item	Lowest Score	Highest Score	Mean
Score	56	77	66

4.1.2 Questionnaire Survey

A semi-structured questionnaire was used, and responses were collected anonymously. 30 questionnaires were distributed, and all were collected back, with all of them being valid.

Findings:

Satisfaction Distribution:

- Overall, satisfaction is relatively low, with 13 people selecting "neutral", 10 people selecting "dissatisfied", and 5 people selecting "very dissatisfied". Only 2 people expressed satisfaction, with no one selecting "very satisfied".
- The highest proportion is "neutral" satisfaction, accounting for 43.3% of the total sample, followed by "dissatisfied" at 33.3%, and "very dissatisfied" at 16.7%.
- Overall satisfaction is low, with a majority of students expressing either dissatisfaction or extreme dissatisfaction.

Grade	Sample Size	Extremely satisfied	Satisfied	Neutral	Dissatisfied	Extremely dissatisfied
Number	30	0	2	13	10	5

Grade	Sample Size	More practical activities	Clearer explanations	More interactive sessions
Number	30	5	5	20

Descriptive Analysis:

Central trend analysis:

Mean: 2.4

Median: 2.5 (lies between unsatisfactory and average)

Plurality: average (most frequent option)



In conclusion, based on the analysis of the satisfaction survey results, the mean satisfaction score of the overall sample is 2.4. the majority of the respondents have a low level of satisfaction, with average being the most frequently selected option, indicating that the students' attitudes towards traditional methods of teaching and learning are generally low.

It is recommended to adopt OBE teaching methods, with improvement measures including the implementation of Task-Based Learning, Project-Based Learning, Problem-Based Learning, and other methods. These approaches center on student inquiries and problem-solving to achieve learning objectives, better meeting students' learning needs, and improving satisfaction.

4. FINDINGS: - 4.2 CYCLE 1

4.2.1 Planning

Analyzing the results of the pre-test and survey questionnaires to determine the current status and satisfaction level of students in education knowledge.

Designing teaching activities, integrating Task-Based Learning, Project-Based Learning, and Problem-Based Learning methods to enhance students' learning outcomes and satisfaction.

Developing a teaching plan, including specific content, schedule, and assessment methods for Task-Based Learning, Project-Based Learning, and Problem-Based Learning.

4.2.2 Action

Implementing Task-Based Learning: designing specific tasks for students to complete in group collaboration to enhance their practical skills and problem-solving abilities.

Implementing Project-Based Learning: organizing students to carry out small-scale projects to learn and apply educational knowledge in practice, enhancing their collaborative and innovative abilities.

Implementing Problem-Based Learning: presenting real-world problems and guiding students to analyze and solve them using their acquired knowledge and skills to develop their problem-solving and critical thinking abilities.

4.2.3 Observation1 - Testing

Findings:

No one failed, 6 passed, 9 were average, 10 were good, and 5 were excellent.

The lowest score was 66, the highest was 91, and the average was 79.2.

Descriptive Analysis:

Most students (24) achieved passing grades or higher, with 10 receiving good grades and 5 receiving excellent grades. No students failed, indicating an overall improvement in student learning compared to the pre-test results.



The average score of 79.2 is higher than the pre-test average, indicating that after applying the OBE teaching method, most students achieved relatively high scores in the test.

Table 5. Cycle 1 test results 1						
Grade	Sample Size	Fail (0-59)	Pass (60-69)	Moderate (70-79)	Good (80-89)	Excellent (90-100)
Number	30	0	6	9	10	5

Table 6. Cycle 1 Pre-test test results 2			
Item	Lowest Score	Highest Score	Mean
Score	66	91	79.2

4.2.3 Observation2 - Survey

Findings:

4 students chose fair, 0 chose dissatisfied, 0 chose very dissatisfied, 18 expressed satisfaction, and 8 chose very satisfied.

Descriptive Analysis:

Central trend analysis:

Mean: 4.13

Median: 4

Plurality: satisfied (most frequently occurring option)

In summary, based on the analysis of the results of the satisfaction survey, the mean satisfaction score of the overall sample is 4.13, indicating that the majority of the respondents hold a high level of satisfaction with the teaching and learning methods using the OBE philosophy. This result is also supported by the median and the plurality, indicating that the majority of the respondents in the sample expressed satisfaction with the teaching methods.

Improvement in Satisfaction:

In the Cycle 1 survey, the majority of students (26) chose satisfied or very satisfied, indicating a significant improvement in satisfaction with the teaching activities.

This may indicate that the improvements and adjustments to the teaching have had some effect, and students have a higher level of recognition for the teaching quality and content.

Remaining Fair Satisfaction:

Despite the overall improvement in satisfaction, some students (4) still chose fair satisfaction, indicating room for further improvement.



This may suggest that there are still some issues or shortcomings in the teaching activities that need to be further analyzed based on student feedback and suggestions for targeted improvement in teaching methods and content.

Dissatisfaction and Very Dissatisfaction:

In the Cycle 1 survey, no students chose dissatisfied or very dissatisfied, indicating a reduction or elimination of dissatisfaction with the teaching activities.

This could be attributed to the improvements and adjustments made to the teaching, leading to a higher level of recognition among students for the teaching quality and content.

In conclusion, the results of the Cycle 1 survey show an overall improvement in student satisfaction with the teaching activities. However, some students still hold a fair level of satisfaction, indicating room for improvement. Therefore, we should continue to pay attention to student feedback and opinions, continuously improve teaching methods and content, and enhance teaching quality and student satisfaction.

Table 7. How satisfied are you with this teaching activity overall?						
Grade	Sample Size	Extremely satisfied	Satisfied	Neutral	Dissatisfied	Extremely dissatisfied
Number	30	8	18	4	0	0

Central trend analysis:

Mean: 2.4

Median: 2.5 (lies between unsatisfactory and average)

Plurality: average (most frequent option)

In conclusion, based on the analysis of the satisfaction survey results, the mean satisfaction score of the overall sample is 2.4. the majority of the respondents have a low level of satisfaction, with average being the most frequently selected option, indicating that the students' attitudes towards traditional methods of teaching and learning are generally low.

Translated with www.DeepL.com/Translator (free version)

4.2.4 Reflection

Through comparing the pre-test and Cycle 1 test results along with the survey outcomes, we can draw the following reflections:

Improvement in test results: In Cycle 1, the test results showed an improvement in the average score of students, and no students failed. This indicates that the adoption of task-based learning, project-based learning, and problem-solving teaching methods has enhanced students' understanding of the subject matter.

Enhancement in satisfaction: The results of the Cycle 1 survey showed an overall improvement in student satisfaction, especially with an increase in the number of satisfied and very satisfied students, and a decrease in the number of neutral students. This suggests that through task-



based learning, project-based learning, and problem-solving teaching methods, student satisfaction with the teaching activities has improved.

Continued improvement: Although some progress was made in Cycle 1, there are still some students who hold a neutral level of satisfaction with the teaching activities, indicating areas for further improvement. Therefore, it is necessary to further analyze student feedback and opinions, identify issues, and take corresponding measures to further enhance teaching quality and student satisfaction.

Results -- 4.3 Cycle 2

4. FINDINGS: -- 4.3 CYCLE 2

4.3.1 Plan

Analyze the test and survey results of Cycle 1, summarize the effectiveness and existing issues, and determine the direction for improvement.

Design teaching activities using the flipped classroom, inquiry-based learning, and case-based teaching methods of OBE to further enhance student learning outcomes and satisfaction.

Develop a teaching plan, including the specific content, schedule, and evaluation methods for the flipped classroom, inquiry-based learning, and case-based teaching.

4.3.2 Action

Implement the flipped classroom: Provide pre-recorded instructional videos and learning materials for students to discuss and practice during class, deepening their understanding and application of knowledge.

Implement inquiry-based learning: Design inquiry-based questions or tasks to guide students in independent exploration and discovery of knowledge, cultivating their problem-solving abilities and critical thinking.

Implement case-based teaching: Introduce real-life cases or scenarios for students to analyze and solve problems, fostering their practical skills and decision-making abilities.

Results -- 4.3 Cycle 2

4.3.3 Observation1 – Testing

Findings:

No students failed, 3 passed, 3 were average, 16 were good, and 8 were excellent.

The lowest score was 77, the highest was 98, and the average score was 90.97.



Descriptive analysis:

The vast majority of students (24) achieved good or excellent grades, with 16 achieving good grades and 8 achieving excellent grades. No students failed, indicating a generally stable level of student learning.

The percentage of students achieving excellent grades is approximately 26.7% (8/30), good grades approximately 53.3% (16/30), average grades approximately 10% (3/30), pass grades approximately 10% (3/30), and failure rate is 0%.

In conclusion, the test results of Cycle 2 show that the majority of students performed well or excellently, with an average score of approximately 90.97, and no students failed. This indicates a significant improvement in students' mastery of knowledge and a good learning outcome through the adoption of flipped classroom, inquiry-based learning, and case-based teaching methods of OBE.

Grade	Sample Size	Fail (0-59)	Pass (60-69)	Moderate (70-79)	Good (80-89)	Excellent (90-100)
Number	30	0	3	3	16	8

4.3.3 Observation2 - Survey

Findings:

Item	Lowest Score	Highest Score	Mean
Score	69	98	88

1 person chose neutral, 0 people chose dissatisfied, 0 people chose very dissatisfied, 19 people expressed satisfaction, and 10 people chose very satisfied.

The satisfaction rate is approximately 63.3%, the very satisfaction rate is approximately 33.3%, the neutral satisfaction rate is approximately 3.3%, and the dissatisfaction and very dissatisfaction rate is 0%.

Descriptive Analysis:

Central trend analysis:

Mean: 4.3

Median: 4

Plurality: satisfied (most frequently occurring option)

In summary, based on the analysis of the results of the satisfaction survey, the mean satisfaction score of the overall sample is about 4.3, indicating that the majority of the respondents hold a high level of satisfaction with the teaching and learning methods using the OBE philosophy.



This result is also supported by the median and the plurality, indicating that the majority of the respondents in the sample expressed satisfaction with the teaching methods.

Survey Stage	Average Score	Central Tendency Analysis
Pre-test	1.93	Most students expressed dissatisfaction with traditional teaching methods, resulting in a low average score (1.93).
Cycle1	4.13	After adopting OBE-concept teaching methods, students' satisfaction significantly increased, with most students choosing satisfied or very satisfied options (average score: 4.13).
Cycle2	4.3	Continuing with OBE-concept teaching methods, students' satisfaction further increased. Although some students expressed neutral attitudes, the majority still chose satisfied or very satisfied options (average score: 4.3).

In the "Pre-test" stage, most students expressed dissatisfaction with traditional teaching methods, resulting in a low average score (1.93).

In the "Cycle1" stage, after adopting OBE-concept teaching methods, students' satisfaction significantly increased, with most students choosing satisfied or very satisfied options (average score: 4.13).

In the "Cycle2" stage, continuing with OBE-concept teaching methods, students' satisfaction further increased. Although some students expressed neutral attitudes, the majority still chose satisfied or very satisfied options (average score: 4.3).

In conclusion, the survey results of Cycle 2 show that the majority of students expressed satisfaction or very satisfaction with the teaching activities, with a satisfaction rate of approximately 63.3% and a very satisfaction rate of approximately 33.3%, while the neutral satisfaction rate is relatively low. No students chose the options of dissatisfied or very dissatisfied, indicating an overall high satisfaction level with the teaching activities and recognition of teaching effectiveness.

Table 10. How satisfied are you with this teaching activity overall?

Grade	Sample Size	Extremely satisfied	Satisfied	Neutral	Dissatisfied	Extremely dissatisfied
Number	30	10	19	1	0	0

4.3.4 Reflection

1. Improvement in Academic Performance:

- In the pre-test, students achieved an average score of 90.97, with no students failing, indicating overall good academic performance.



- In Cycle 1, the implementation of task-based learning, project-based learning, and problem-solving teaching methods led to further improvement in students' mastery of knowledge.

- In Cycle 2, the adoption of OBE methods such as flipped classrooms, inquiry-based learning, and case-based teaching resulted in further enhancement of student performance, with most students performing well or excellently.

2. Enhancement in Satisfaction:

- In the pre-test and Cycle 1 surveys, overall satisfaction with the teaching activities was relatively low, with most students selecting satisfaction levels of "neutral" or below.

- In the Cycle 2 survey, satisfaction levels significantly improved, with the majority of students selecting "satisfied" or "very satisfied," and no students choosing "dissatisfied" or "very dissatisfied."

3. Effectiveness of Teaching Methods:

- A comparison between the pre-test, Cycle 1, and Cycle 2 indicates that the use of task-based learning, project-based learning, problem-solving teaching, as well as flipped classrooms, inquiry-based learning, and case-based teaching, effectively promotes students' academic performance and satisfaction.

- These teaching methods stimulate students' interest in learning, enhance their motivation, and develop their practical and innovative abilities, thereby improving teaching quality and satisfaction.

5. CONCLUSION

In this action research, our goal was to enhance the knowledge mastery of third-year undergraduate students majoring in education at Dongguan Urban University by implementing the OBE (Outcome-Based Education) approach to address teaching issues.

Through this action research, we found that adopting the OBE approach combined with various teaching methods such as task-based learning, project-based learning, problem-solving teaching, flipped classrooms, inquiry-based learning, and case-based teaching, effectively improves students' academic performance and satisfaction.

In Cycle 1 and Cycle 2, students' average scores continued to increase, and satisfaction also gradually improved, indicating that the improvements and adjustments to teaching activities were effective. However, some students still expressed neutral satisfaction, indicating the need for continued attention to student feedback, ongoing improvement of teaching strategies and methods, to ensure sustained improvement in teaching quality.



6. DISCUSSION

Overall, this action research provides an effective framework for teaching improvement, demonstrating how the OBE approach and various teaching methods can optimize teaching practices.

Through continuous observation, reflection, and adjustment, we can continuously improve teaching activities, enhance students' academic performance and satisfaction, providing valuable insights and guidance for educational work.



090-056

HISTORY TEACHING AND MULTI-DISCIPLINARY INTEGRATION:AN ANALYSIS AMONG JUNIOR HIGH SCHOOL STUDENTS IN CHINA

Han Limin

Faculty of Education, University Kebangsaan Malaysia
E-mail: 195514367@qq.com

Anuar Ahmad

Faculty of Education, University Kebangsaan Malaysia
E-mail: anuarmd@ukm.edu.my

Jamsari Alias

Pusat Pengajian Citra Universiti(School of Liberal Studies) ,
Universiti Kebangsaan Malaysia
E-mail: jamsari@ukm.edu.my

Sun Lingchen

Development Planning Division & H the Discipline Construction Office of
Changchun Normal University, Jilin province
E-mail: 1527741@qq.com

ABSTRACT

This paper aims to deeply analyze the internal connection between history teaching and multidisciplinary integration in junior middle school and its practical strategies. The paper first makes a detailed analysis of the current situation of history teaching, and emphasizes the close connection between history teaching and other subjects. This paper points out that this integration is of vital significance for improving students' comprehensive quality and interdisciplinary thinking ability. Secondly, the paper expounds the necessity and feasibility of the integration of history teaching and multi-disciplines in junior high school from the perspective of theory and practice. This paper believes that this kind of integration can not only stimulate students "interest in learning, but also help to cultivate students" critical thinking and promote students' all-round development. Finally, this paper presents a series of specific suggestions for the implementation of multidisciplinary integration teaching. These suggestions include interdisciplinary curriculum design, innovation of teaching methods and the transformation of teachers, aiming to provide powerful reference and guidance for improving and improving the quality of history teaching in junior middle school.

Keywords: Junior Middle School, History Teaching, Multi-Disciplinary Integration, Interdisciplinary Thinking.

INTRODUCTION

The continuous innovation of the international history education concept has provided a steady stream of power for the progress of history teaching, promoted the continuous evolution of teaching methods, and promoted the increasingly diversified forms of inquiry. In this context,



junior high school history teaching is facing unprecedented challenges and opportunities, which urgently needs us to respond prudently and actively grasp. The traditional history teaching mode is often limited to the knowledge teaching of a single subject and lacks the cross-integration with other disciplines, which to a large extent limits the cultivation of students' comprehensive quality and interdisciplinary thinking ability. In order to meet the educational needs of the new era, more and more scholars and practitioners begin to pay attention to the internal connection between the integration of junior high school history teaching and their practical strategies.

Based on the characteristics of history discipline, the History Curriculum Standard of Compulsory Education in China condenses the core qualities of history discipline and points out the objectives of history teaching in the new period. In order to achieve this goal, teachers should closely follow the characteristics of history subject and choose appropriate teaching methods. As is known to all, the discipline of history " is multi-dimensional, comprehensive and complex, such as the history and theory of highly unified (Zhang Baocheng, 2022) . This determines that history is inseparable from other disciplines. At the same time, history itself is a comprehensive subject composed of other disciplines, so teachers should carry out multi-disciplinary integration teaching. Multi-disciplinary integration teaching refers to the teaching activities that integrate the relevant subject content into the classroom based on the convergence points between disciplines to assist students in learning (Tao Jia, Dai Ninghua. 2022). The integrated teaching of multidisciplinary history can cultivate students' core qualities. Through the integration of history and morality and rule of law, teachers can construct a good historical materialism, and history and geography disciplines. This topic mainly studies the integration of history teaching and multidisciplinary in junior high school.

History discipline is comprehensive and closely related to other disciplines. After continuous attention and emphasis on the life problems of teenagers, related projects gradually faded out of view (Applebee, 1974). Although its early history was not satisfactory, interdisciplinary projects have always shown tenacious vitality in different periods. For example, the core project of the 1950s (Henry, 1958) and the humanities project of the 1960s (Schwartz, 1970) were both important milestones in the interdisciplinary field. The emergence and revival of these projects not only reflects the spirit of continuous exploration and innovation in the academic circle, but also provides valuable experience and inspiration for subsequent research and practice. In recent years, the development of the interdisciplinary curriculum has received extensive attention and calls, which is closely related to the broader curriculum and teaching reform, as noted by Sizer (1996). After in-depth research and a lot of practice, it shows that interdisciplinary teaching methods have the remarkable potential to improve student participation, promote academic performance and revive the traditional education model. These methods not only effectively map the complex and diverse problems in the "real world", but also provide students with a comprehensive and in-depth learning experience by integrating knowledge and perspectives from different disciplines (Beane, 1997; Jacobs, 1997; Tchudi & Lafer, 1996).

Returning to the essence of the discipline, the historical knowledge and even the research object itself are comprehensive, covering all aspects of many fields and various stages of human life. Teachers conduct multi-disciplinary integration teaching in the history classroom, which can fully combine the knowledge content, logical thinking, methods and skills of other disciplines to help students to recognize the historical content, supplement the knowledge separation, peel off the surface, and subtly develop the core literacy. Based on this, teachers should integrate



their own teaching experience and discuss the strategies of historical multidisciplinary teaching in detail, so that students can develop their core literacy while mastering historical knowledge.

THE ASSOCIATION BETWEEN HISTORY TEACHING AND MULTIPLE-DISCIPLINES

Under the current educational background, the close connection between junior high school history teaching and other disciplines has gradually emerged. History is no longer an isolated discipline, but it permeates and supports other disciplines. Junior high school history educators are committed to history teaching as the core, actively introducing and flexibly using the knowledge, theories and methods of other disciplines, are committed to building a comprehensive and systematic knowledge system, and then weaving a network of comprehensive capabilities. Their efforts aim to promote the overall improvement of students' quality and ability, and lay a solid foundation for the all-round development of students (Sun Jie, 2016). Teacher Tang Yuanyuan from Nanjing Foreign Language School presented the interdisciplinary inquiry course "—— History and Culture of tile". The course integrates history and art, and displays the combination of history and culture through the historical materials of tile cultural relics. Teacher Tang made imported videos and displayed pictures of cultural relics to enhance the students' understanding of tile dang. This course reflects the school's exploration in education and teaching reform, and helps to cultivate students' comprehensive quality and innovation ability (Zhao Yingying, 2019). While deeply examining research and promotional materials related to the interdisciplinary approach, we adopted the framework of the interdisciplinary continuum to highlight important evolution across projects (Adler & Flihan, 1997; Applebee, Burroughs, & Cruz, 2000).

THE IMPORTANCE OF HISTORY TEACHING AND MULTI-DISCIPLINARY INTEGRATION

With the rapid development of science and technology and the continuous progress of society, the demand for talents in modern society is also undergoing profound changes. Pure professional skills can no longer meet the diversified needs of The Times, and having interdisciplinary knowledge structure and critical thinking ability have become the core characteristics of modern talents. Therefore, multi-disciplinary integration education has become a key way to cultivate students' comprehensive literacy and cross-field critical thinking ability.

First of all, multi-disciplinary integrated education plays a significant role in improving students' comprehensive literacy. By integrating the knowledge and methods of different disciplines, students can be exposed to a wider range of knowledge fields, thus broadening their horizons and enhancing their comprehensive literacy. For example, when solving complex problems, students need to use mathematics, physics, chemistry, and other multidisciplinary knowledge. This comprehensive way of thinking helps to cultivate students' innovative ability and the ability to solve practical problems.

Secondly, multi-disciplinary integration education helps to cultivate students' cross-field critical thinking ability. In the traditional single-subject education, students are often limited to the knowledge and skills of the discipline, and lack of integration and interaction with other disciplines. The multi-disciplinary integration education encourages students to cross the disciplinary boundaries, integrate the knowledge and methods of different disciplines, and then



cultivate students' cross-field critical thinking ability. This kind of thinking ability not only helps students to solve practical problems, but also helps them to adapt to the challenges of rapid social changes in the future.

In addition, the multidisciplinary integration education also helps to cultivate students' teamwork spirit and communication skills. In interdisciplinary projects, students need to work closely with students from different academic backgrounds to overcome difficult problems together. This collaborative process helps to foster students' teamwork spirit and communication skills, laying a solid foundation for their future development.

To sum up, the integration of history teaching in junior high school and multidisciplinary teaching has become one of the hot spots of the current educational reform. By exploring the internal connection of this integration and its practical strategies, we can provide useful enlightenment and reference for improving and improving the quality of the junior middle school history teaching.

THE IMPORTANCE OF HISTORY AND MULTI-DISCIPLINARY INTEGRATION

With the teaching concept of core literacy education, China's education and teaching work has undergone a great change, and cultivating students' core literacy has become one of the main teaching objectives. In this context, multi-disciplinary integrated teaching has been born, and gradually applied to the teaching work of various disciplines, which has played an important role in promoting the cultivation and promotion of students' core literacy. Under the guidance of the concept of core literacy, junior high school history teachers should fully explore the connection and convergence points between history disciplines and other disciplines, improve the quality and level of classroom teaching, guide students to master the corresponding history knowledge more in-depth and specifically, and promote the development of students' core literacy of history.

1.THE PROFOUND CONNOTATION OF THE CORE LITERACY EDUCATION AND TEACHING CONCEPT

Core literacy refers to the basic and key abilities and qualities that students must master in the process of receiving education. It emphasizes not only the accumulation of knowledge, but also focuses on the cultivation and promotion of students' comprehensive quality. Therefore, while teaching history knowledge, junior middle school history teaching should pay more attention to cultivating students' core qualities such as historical thinking and historical interpretation.

2.THE UNIQUE ADVANTAGE OF MULTI-DISCIPLINARY INTEGRATION TEACHING

Multi-disciplinary integration teaching is an innovative teaching mode, which enables students to understand and understand the problems more comprehensively by integrating the knowledge and methods of different disciplines. This mode can not only broaden students' knowledge horizon, but also effectively improve students' comprehensive quality and innovation ability.



3. THE ORGANIC COMBINATION OF JUNIOR HIGH SCHOOL HISTORY TEACHING AND MULTI— DISCIPLINARY INTEGRATION

As a comprehensive discipline, junior high school history has a natural connection with other disciplines. For example, the combination of history and Chinese can help students better understand historical documents and historical materials; the combination of history and mathematics can help students use statistics and data analysis and study historical events; the combination of history and geography can help students better understand the historical and geographical background and spatial layout.

PRACTICAL SIGNIFICANCE

1. BROADEN THE KNOWLEDGE HORIZON, IMPROVE THE COMPREHENSIVE QUALITY

History teaching in junior high school involves politics, economic fields, culture and other fields. Integrating with multidisciplinary teaching can help students to have a more comprehensive and deep understanding of historical events and phenomena, so as to broaden their knowledge horizon. At the same time, this teaching mode helps to cultivate students' comprehensive quality, including the ability to analyze problems, critical thinking, innovative spirit, etc., to lay a solid foundation for their future development.

2. STIMULATE THE INTEREST IN LEARNING, IMPROVE THE TEACHING EFFECT

Traditional junior high school history teaching is based on teaching, which is easy to make students feel boring. By introducing multi-disciplinary integration teaching, the knowledge and methods of other disciplines makes the teaching content more vivid and interesting, so as to stimulate students' interest in learning. This teaching method can not only improve the students' learning enthusiasm, but also improve the teaching effect, so that the students can better master the knowledge of history.

3. CULTIVATE INTERDISCIPLINARY THINKING AND IMPROVE THE ABILITY TO SOLVE PROBLEMS

Multidisciplinary integration teaching helps to cultivate students' interdisciplinary thinking, so that they can comprehensively consider the knowledge and methods of multiple disciplines when solving problems. This thinking mode helps to improve students' problem-solving ability, so that they can more comprehensively and deeply analyze and think in the face of complex problems.

The connotation of multidisciplinary integration is rich, which reflects the inherent requirements of scientific development and the trend of the progress of The Times. It not only promotes the exchange and cooperation between different disciplines, promotes the innovation and development of scientific knowledge, but also improves the ability to solve practical problems, and provides a more comprehensive, in-depth and effective solution for social development. Therefore, multidisciplinary integration has important theoretical value and



practical significance, which is worth our in-depth research and exploration. (Chart 2.3.1, Chart2.3.2, Chart2.3.3)

Chart 2.3.1

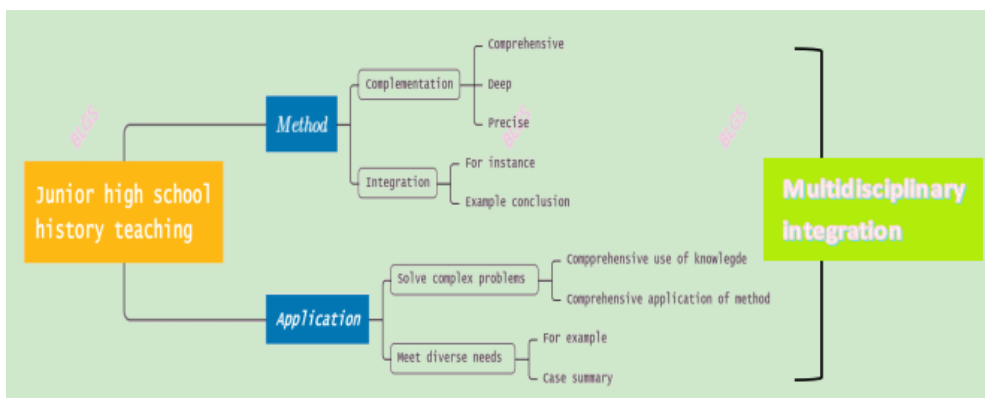

Chart 2.3.2

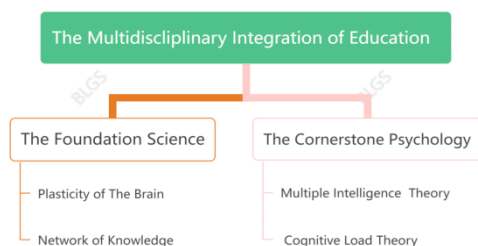
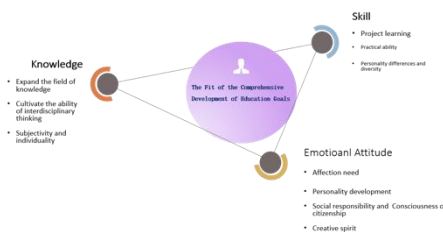

Chart 2.3.3



(a) IMPORTANCE

History curriculum is a vital part of the secondary education system, which aims to provide students with a deep understanding of the history and culture of our country and the world. As a humanities discipline, history course not only helps to improve students' knowledge and cultural level, but also plays an irreplaceable role in shaping a sound personality and promoting students' lifelong development. In middle school, students' body and mind are not fully mature. Therefore, the goal of the history course is to cultivate them to form a healthy personality and a correct world outlook, outlook on life and values.

History teachers should not only impart knowledge, but also guide students to comprehensively examine human history and actively expand their knowledge vision. By teaching students how to collect and analyze historical materials, and to develop their ability to think and solve problems independently, history courses offer students valuable learning opportunities.

In the teaching process, history teachers should not only be limited to the teaching of book knowledge, but should devote themselves to improving students' thinking ability and helping them clarify the context of historical development. By connecting the horizontal historical events with the vertical historical development, a comprehensive and systematic knowledge system is constructed, so that students can understand and grasp the history more deeply.



Moreover, history does not exist in isolation from other disciplines. When learning the history, the students should use the interdisciplinary knowledge and methods to integrate the history knowledge with the knowledge of other disciplines to form a comprehensive learning model. The current middle school history textbooks cover many fields, such as Chinese history and world history, political system history, social and economic history, ideological and cultural history, which requires teachers to pay attention to interdisciplinary integration in the teaching process, and make full use of various teaching resources to provide students with more comprehensive and in-depth learning experience.

To sum up, the history curriculum plays a very important role in the middle school education. It is not only related to the improvement of students' knowledge and cultural level, but also plays an important role in shaping students' personality and promoting their lifelong development. By improving teaching methods and means, as well as focusing on interdisciplinary integration, we are able to provide students with better history education and lay a solid foundation for their future development.

(b) FEASIBILITY

When discussing the feasibility of integrating history teaching with multidisciplinary subjects in junior high schools, we have to pay attention to the important field of world history. Whether in high school or junior high school, world history occupies a prominent position in textbooks, especially the upper and second volumes of grade 9 in junior high school, which are specially designed for world history. This part of the content is not only important for students, but also strange, which is relatively difficult to master. Compared with Chinese history, students' knowledge reserve of world history, especially ancient history, is obviously insufficient.

In order to help students better understand and accept world history, we can consider integrating English historical materials into their teaching. By the introduction of first-hand historical materials, we can restore the real appearance of history, so that students have a sense of substitution, so as to have a deeper understanding of historical facts. This method is not only helpful to the teaching of the history subject, but also can take into account the students' English learning, stimulate the students' interest in learning, and mobilize their subjective initiative.

To achieve this goal, history teachers need to have the ability to be flexible and skilled in using English. In this way, in history teaching, teachers can explain historical events in English, so that students can also improve their English level while learning history. This interdisciplinary teaching method can not only help to improve the quality of teaching, but also help students to establish a good image of teachers.

Taking the textbook as an example, we can find that many chapters are suitable for the introduction of English historical materials, such as festivals, modern Olympic Games, a brief history of weekends, Peking Opera, Tang costume, etc. In the high school textbooks, there are many chapters that are closely linked to history, such as Anne Anne, English, former South African President Nelson Mandela, cultural heritage, the United Kingdom of Great Britain, art, Martin Luther King's famous speech "I Have a Dream" and so on.

In short, it is completely feasible to integrate junior high school history teaching with multiple disciplines. By introducing multi-disciplinary historical materials and interdisciplinary teaching methods, we can help students to better understand the historical issues and feel the charm of different cultures, so as to improve the effectiveness of teaching. At the same time,



this teaching method also helps to improve students' multi-disciplinary integration learning ability, cultivate their interdisciplinary thinking, and lay a solid foundation for their all-round development.

THE PRACTICAL EXPLORATION OF MULTI-DISCIPLINARY INTEGRATION AMONG JUNIOR MIDDLE SCHOOL HISTORY TEACHING

"Soul" is the only core of the interdisciplinary activity inquiry course, and "degree" is the principle of applying the resources of other disciplines. The inquiry course of interdisciplinary history activities in junior high school must adhere to the subjectivity of history teaching characteristics. This requires the history teachers to grasp the principles of applying the resources of other disciplines in the interdisciplinary teaching design (Zhao Yingying, 2019). Junior middle school history textbooks compiled by the Ministry of China were compiled according to the 2011 edition of the history curriculum standards for compulsory education, and the new edition of the textbooks and the new curriculum standards were popularized in 2017. In chronological order, from ancient times to the present, the basic context of historical development is described. The history course consists of two themes: Chinese history and world history. (Chat History Curriculum Standards for Compulsory Education)

Chat History Curriculum Standards for Compulsory Education



In planning and multidisciplinary integration curriculum implementation, provide more flexible framework, according to the school background, faculty and students 'ability and interest diversity for course, by history teaching a theme, projected to the multidisciplinary related chain knowledge, thus a boring boring strange historical space into the perception through the real historical events, the nature of the historical events and the reason behind the deep understanding, and effectively improve students' comprehensive analysis ability.

Chat Curriculum Design Idea Module

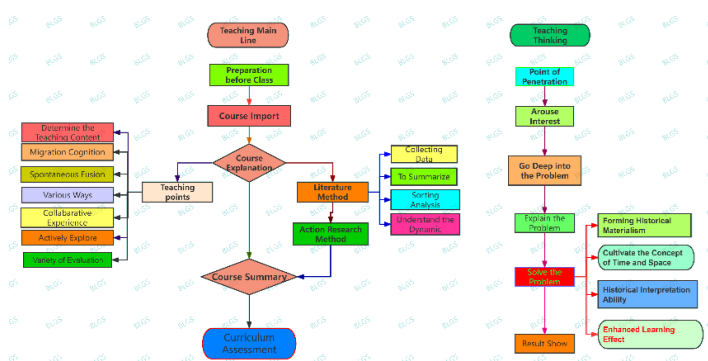



LESSON PREPARATION: MULTI-DISCIPLINARY INTEGRATION, TO FIND THE RIGHT MEETING POINT

Multi-disciplinary integration teaching is an activity based on the convergence point between disciplines. Finding the convergence point between disciplines is the basis for teachers to effectively implement multi-disciplinary integration teaching. Lesson preparation is an important link for teachers to find the meeting point between subjects. Therefore, in the implementation of history multi-disciplinary integration teaching, teachers should base on the link of lesson preparation, study the history teaching content, explore its connection with other disciplines, so as to determine the convergence point, such as determining the teaching content, clarifying the core quality, so as to promote the smooth development of classroom teaching. Take the "turbulent Spring and Autumn Period" as an example, the profound change from the economic development to the social system in the Spring and Autumn Period is the teaching point of this lesson. During the Spring and Autumn Period, agriculture, handicraft industry and commerce played an important role in economic development. In agricultural production, the use of iron farm tools and cattle farming destroyed the original well field system, resulting in the collapse of the partition system. At this time, the original political system — Enfeoffment system (of the Western Zhou Dynasty, c. 11 th. century-771 B.C., investing the nobility with hereditary titles, territories and slaves), can not meet the development of the relations of production. The vassals have to reform, resulting in the new class — Landlord class. The emergence of the landlord class promoted the arrival of the feudal society. It can be seen that the change of production tools drives the improvement of productivity and promotes the human process. Historical materialism points out that the productive forces determine the relations of production, and the economic foundation determines the superstructure. By integrating historical materialism into the classroom, students can have a deep understanding of the teaching points of this lesson. Therefore, through such interpretation of the subject content, teachers have found the convergence point of history discipline and morality and rule of law discipline — Historical Materialism. At the same time, students will develop historical materialism by understanding this content.

INTRODUCTION: MULTI-DISCIPLINARY INTEGRATION, TO STIMULATE STUDENTS' INTEREST

The introduction process is the starting point for bringing students into the learning situation. Learning interest is the support for students to enter the learning situation. (Tao Jia, 2022). Therefore, in the classroom introduction link, the teacher should first stimulate the students' interest in learning. The unknown content is a "tool" to stimulate students' interest. In the introduction of history classroom, teachers can integrate other subjects, make students have a sense of familiarity, ask questions and show the unknown content, so as to arouse students' interest, promote them to transfer their existing cognition, actively explore, and effectively enter the history classroom. Take the "confrontation between the Jin and the Southern Song" as an example. In the era of the confrontation between the Jin and the Southern Song, many people wrote touching poems based on the actual situation, such as Yue Fei wrote "All over the River Red". In the Chinese class, the students learned the "Full River Red", to understand the creation background of the poem, the specific content and the thoughts and emotions contained in it. Therefore, in the classroom introduction link, the teacher used the interactive electronic whiteboard to play the video of "All over the River Red". Spectacular scene, moving recitation, it is easy to attract students' attention. Under the action of vision and hearing, the students walked into the historical scene at that time, and at the same time consciously transferred their existing cognition, felt the confrontation between the Southern Song Dynasty and the Jin



Dynasty, and realized the heroic spirit of the soldiers of the Southern Song Dynasty. After the video, the teacher asked the students: "Yue Fei led the 'Yue Jia army' to resist Jin's invasion. Why did the Jin invade the Southern Song? How did gold come up? What was the result of the confrontation between the Southern Song Dynasty and the Jin Dynasty?" At this time, the students have a strong interest in inquiry. Some students consciously transfer their existing cognition, explore the relevant content of the confrontation between the Southern Song Dynasty and the Jin Dynasty, and really walk into the history class. It can be seen that multi-disciplinary integration can create appropriate historical situation, stimulate students' interest in learning, make students spontaneously integrate subject content and actively explore historical knowledge.

EXPLANATION: MULTI-DISCIPLINARY INTEGRATION, DEEPEN THE UNDERSTANDING OF PROBLEMS

Problem solving is one of the ways students learn history. Classroom explanation link is an important link for students to solve all kinds of historical problems. In the explanation link, teachers should combine the history teaching content, set up different problems, and apply appropriate ways to guide students to solve the problems, so that they can deepen the understanding of the problems, firmly master the historical knowledge, and develop the core quality of the history discipline. There are many ways to solve historical problems, and the graph reading method is one of them (Yao Lin, 2021). In the process of reading pictures, students can transfer geographic experience to find key information, thus exploring historical content and solving problems. At the same time, the students thus form the concept of time and space. Therefore, in the classroom explanation link, teachers can ask questions and guide students to read pictures. Take "opening to the outside world" as an example, one of the key teaching points of this course is the characteristics of the changing pattern of opening to the outside world. Based on this, in the classroom, the teacher distributes an administrative map of China to each student. Combined with the key points and the map content, the teacher asked a series of questions to the students. The teacher first proposed to the students: "In 1980, where did China establish a special zone?" At the same time, the teacher asked the students to draw special circles on the map. With such questions and requirements, students read the history textbooks, find four special zones, and circle them on the map. Based on this, the teacher continued to ask: "Why are the special zones established in these four places?" At this time, many students transferred their geographical experience and examined the geographical location of the four special zones from a geographical perspective, thus getting the answer. For example, "these four cities are coastal cities with convenient transportation" and "these four cities are located in the southeast coastal areas, which is easy to communicate with overseas". The teacher made the students understand the real reasons for the establishment of the four special zones. Then, in this way, teachers continued to ask: "Which coastal cities has China opened up in 1984? What coastal special economic zones were established in 1985? Which special economic zone was established in 1988? Which coastal cities were opened in 1992?" Driven by the question, the students walked into the history textbooks, searched for the relevant content, and consciously circled them on the map. At the same time, students have experienced the process of China's opening to the outside world and intuitively see the pattern. Based on this, the teacher proposed the cooperation task: "Please share their maps with the team members, discuss the opening of these cities, or as special economic zones." Driven by the task, students continue to transfer their geographical cognition, analyze the geographical location of the painted cities, so as to understand the reasons. Finally, the teacher selects a student and encourages him to show his map. According to the content of the circle painting, he introduces the formation process, changes and characteristics of the opening pattern of



China. In the introduction, the student representatives expressed logically and clearly, such as "China's opening pattern experienced the change process from 'point' to 'line' and then to 'surface' ". According to the content of the expression, teachers make a timely summary to promote students to improve their cognition. Practice has proved that, driven by the problems, the students transfer the geographical experience and read the map carefully, realize the spatial positioning of the historical content in the map, and master the historical knowledge with the help of the spatial characteristics. At the same time, students also feel the change of time in the space environment, which is conducive to the formation of the concept of time and space and the development of spatial generalization ability.

MULTI-DISCIPLINARY INTEGRATION, HISTORICAL INTERPRETATION

Historical interpretation is one of the ways that students can enhance their knowledge of history. The summary link is the link for students to explain their history. In the process of participating in the history classroom teaching, the students experience a variety of activities and master the history knowledge, which provides a convenience for the history interpretation. At the same time, historical interpretation is an activity for students to integrate multidisciplinary content. For example, students can use the writing method of Chinese subject to integrate historical information and make historical explanations, or they can use maps to explain the historical content. In the classroom summary link, teachers can choose appropriate ways according to the students' history and other subjects learning situation, and guide them to explain the history, so as to enhance their historical cognition. Taking the "weather of the Tang Dynasty" as an example, in the classroom, teachers focus on the performance of the prosperity of the Tang Dynasty, take economic, ethnic relations, social atmosphere, literary and artistic achievements as the key points, into the geography, Chinese, art and other subjects, to promote students to master the key content. For example, with the help of the commercial, agriculture and handicraft industry, the economic development of the Tang Dynasty, the relationship of the Tang Dynasty, the Tang Dynasty, and calligraphy, painting, Tang poetry, the literary and artistic achievements of the Tang Dynasty. Based on this, the teacher in the summary link, to the students put forward writing requirements: "please review the content of this lesson, cooperate with group members, respectively to" remember the prosperity of Tang ", " Tang open ", " Tang ethos ", " Tang literature " as the theme, write a historical composition, the number of words in about 300 words." In this request, the students have cooperated with the group members, according to their respective learning situation, select the theme. At the same time, the students revolve around the selected topics, use their brains to review the relevant content, and obtain rich writing materials. After that, students transfer their writing experience, outline, clarify their writing ideas, organize language and introduce relevant content. After the prescribed writing time, the students take the initiative to share their small compositions with the group members. When others read the composition, other students listen carefully and add the relevant content according to their own learning situation. Through such cooperation, most of the groups completed a historical composition of both quality and beauty. So, the teacher encouraged the group to recommend themselves and read a small composition. In fact, through the recitation of different groups, other students learned about the prosperous performance of the Tang Dynasty again and again, so as to make up for the lack of learning and deepen their understanding of what they had learned.

MULTI-DISCIPLINARY INTEGRATION, COMPREHENSIVE PROBLEM SOLVING

Teaching evaluation runs through history teaching and has various ways, such as diagnostic evaluation and process evaluation. In the history classroom, teachers can choose different



evaluation methods according to their teaching needs. For example, after students master the historical knowledge of history, teachers can present relevant historical test questions, guide students to solve them, so that they can understand their own learning situation, find the shortcomings, consciously check the omissions and fill the gaps, and have a solid grasp of what they have learned. Some test questions need students to use the content of other subjects to solve. Therefore, in the implementation of history teaching, teachers can base on the teaching content, integrate other disciplines, design the test questions, drive students to integrate the subject content, solve problems, and give full play to the value of diagnosis and evaluation.

STRATEGIES AND SUGGESTIONS FOR IMPLEMENTING MULTI-DISCIPLINARY INTEGRATED TEACHING

In order to effectively implement the multidisciplinary integration teaching, junior middle school history teachers should adopt the following strategies:

(I) Strengthen the exchange and cooperation with teachers of other disciplines, and jointly explore the interdisciplinary teaching modes and methods.

(II) According to the students' cognitive characteristics and needs, the teaching content and teaching methods are carefully designed to ensure the maximum teaching effect.

(III) Pay attention to students' subjectivity and practicality, encourage students to actively participate in teaching activities, and improve their independent learning and cooperative learning ability.

(IV) Summarize and reflect on the teaching experience in time, constantly optimize the teaching design, and promote the in-depth development of multi-disciplinary integrated teaching.

In a word, the integration of junior history teaching and multi-disciplines is one of the important directions of education and teaching reform. Through the implementation of this teaching mode, students' core literacy can be cultivated more effectively and lay a solid foundation for students' all-round development.

CONCLUSION

To sum up, the multi-disciplinary integration teaching can enable students to integrate the knowledge, master the historical content, and develop the core quality of the history discipline. Based on this, in the implementation of junior high school history teaching, teachers can be based on history characteristics, according to its contact with other disciplines, with different teaching link as the foothold, a variety of ways, into the interdisciplinary content, generate a variety of teaching activities, such as situation, problem solving activities, make students migration cognitive, explore history knowledge, construct good cognition, at the same time form historical materialism, cultivate the concept of time and space, history interpretation ability, etc., enhance the effect of history learning.



REFERENCES

- Applebee, A. N. (1993). *Literature in the secondary school: Studies of curriculum and instruction in the United States*. Urbana, IL: National Council of Teachers of English.
- Beane, J. (1997). *Curriculum integration: Designing the core of democratic education*. New York: Teachers College Press.
- Han Limin. The eve of junior high school history teaching and multi-disciplinary integration. The national key project of the 14th Five-Year Plan of the Ministry of Education under the Ministry of Education, 2023.7
- Henry, N. B. (Ed.). (1958). *The integration of educational experiences (57th Yearbook of the National Society for the Study of Education)*. Chicago: University of Chicago Press
- Schwartz, S. (Ed.). (1970). *Teaching the humanities*. New York: Macmillan
- Sun Jie, junior high school history interdisciplinary teaching practice and exploration [C] // Jiangsu Education Association. 2016 Annual Conference report of Jiangsu Education Association. Suzhou: Jiangsu Provincial Education Association, 2016:126
- Sizer, T. R. (1996). *Horace's hope: What works for the American high school*. Boston: Houghton Mifflin.
- Tao Jia, Dai Ninghua. Multiple integration: Exploration of the integration of literature and history in junior high school history teaching [J]. *Middle school history teaching reference*, 2022 (08): 88-89.
- Tchudi, S., & Lafer, S. (1996). *The interdisciplinary teacher's handbook: Integrated teaching across the curriculum*. Portsmouth, NH: Boynton Cook/Heinemann.
- Yao Lin. History teaching in junior high school from the perspective of subject integration: Take the "Integration teaching of The Three Kingdoms" as an example [J]. *Liberal arts lovers (Education and Teaching)*, 2021 (05): 114-115.
- Yingying Zhao, J. (March 10, 2019). The "soul" and "degree" of the interdisciplinary activity of junior high school history. *Middle school history teaching reference*.
- Zhang Baocheng. Research on the classroom teaching strategies of junior high school history based on core literacy [J]. *Student Weekly*, 2022 (04): 77-78.
- Zhou Li. Thoughts on history Classroom Teaching in junior Middle School from the perspective of subject integration [J]. *Middle school teaching reference*, 2021 (31): 55-56.



093-062

CONFIRMATORY FACTOR ANALYSIS OF CONTINUOUS PROFESSIONAL DEVELOPMENT CONSTRUCTS AMONG ISLAMIC EDUCATION TEACHER

Azwani Masuwai
Faculty of Education
National University of Malaysia, 43600 Bangi, Malaysia
Email: azwanimasuwai@yahoo.com, Tel: 013-3251341

Dr. Hafizhah Zulkifli
Faculty of Education
National University of Malaysia, 43600 Bangi, Malaysia
Email: hafizhah_zulkifli@ukm.edu.my, Tel: 019-6285626

Dr. Mohd Isa Hamzah
Faculty of Education
National University of Malaysia, 43600 Bangi, Malaysia
Email: isa_hamzah@ukm.edu.my, Tel: 019-3372790

ABSTRACT

Professional development for educators entails the adoption of high-quality practices and effective traits as they strive independently to attain excellence in their field. The purpose of this study is to explore the constructs of continuous professional development among Islamic education teacher in secondary school. The study employed a survey design that administered to 420 Islamic Education Teacher from 63 secondary school in Malaysia which were selected using multistage sampling technique with the instrument named the Continuous Professionalism Development Instrument - Islamic Education Teacher (CPDI-IET). Confirmatory Factor Analysis (CFA) was used to test for model fit, reliability and validity of the construct measured. The CFA results yielded three constructs of CPD elements which are Basic, Competency Development and Special Needs. All constructs indicated goodness of fit indices; Basic: Setting Goals (10 items): TLI=0.95, CFI=0.96, RMSEA=0.08) and Basic: Prioritizing Self-Confidence (6 items): TLI=0.96, CFI=0.98, RMSEA=0.10). Factor loading for all items were more than 0.5 as well as high reliability and internal consistency (Average Variance Extracted; Construct Reliability). Specifically, this study provides recommendation constructs of CPD-IET in secondary schools that may contribute to higher achievement towards educational development.

Keywords: Continuous professional development, Islamic education teacher, secondary school, confirmatory factor analysis, instrument validation.



1. INTRODUCTION

1.1 Professional Development

Ideally, the professional development of the teacher is the quality practices and effective characteristics that acts on his own towards achieving excellence. However, teacher professional development activities that emphasize on the development of teachers' competency are still resulted to be at a less than satisfactory level. Teachers were found to still fail to deliver their teaching and learning (TNL) effectively especially involving Higher Order Thinking Skills (HOTS) (Ministry of Education - MoE, 2012). The aim of educators to cultivate students' proficiency in reasoning may face challenges in achieving optimal outcomes (Rashed et al., 2017). Teachers' acceptance of the learning characteristics of the 21st century remained at moderate level (Ismail & Ismail, 2018) and some teachers may lack proficiency in technology and communication, which can make it challenging for them to embrace and adapt to the latest advancements and changes (Ramli & Nor, 2018).

A study by Zabidi et al. (2008), Hassan et al. (2009) and Idris & Hamzah (2013) show that the level of teacher professionalism is still at low and moderate level. Some outstanding teachers may not excel in public speaking but demonstrate exceptional skills in fostering positive relationships and possess strengths in other areas, such as managing classroom dynamics or facilitating discussions (Jasmi & Tamuri, 2015). There exists an innovation gap among teachers who possess valuable ideas and talents but lack the necessary knowledge or skills to fully implement them (Muhammad, 2015). Therefore, implementing additional training programs is essential as an alternative to enhance teachers' competency and address the various issues that arise within the educational landscape.

The concept of worship in the teaching profession is gradually disappearing. Numerous teachers are experiencing confusion and oversight regarding the fact that the act of educating is fundamentally an expression of reverence, untainted by the pursuit of material wealth, recognition, or status (Noordin & Dan, 2002). As a result, a decline in faith and respect for teachers' authority within society may emerge (Idris & Hamzah, 2013). Teachers need to be sincere, honest and conscientious in carrying out their duties. Guidance and supervision as well as appreciation of the duties and responsibilities of teachers are required for example the need to attend seminars and workshops, coaching and mentoring, professional learning community (PLC) between colleagues and various other activities to facilitate teacher's goals and focus. As stated by Hussin (2004) that professional development programs will help teachers to think about the moral impact of their actions.

Eliza et al. (2022) have listed the characteristics of a teacher's professionalism which are: (1) the desire to always behave as a model; (2) strive to develop and maintain professional behaviour like self-appearance, speech, use of language, health, and daily attitude; and (3) admire to attend professional development training to increase and expand knowledge and skills. Whist, Jaafar (2022) in her study related to self-efficacy, has suggested several contents for in-service training including: (1) focusing on teacher self-development such as self-awareness, self-efficacy and self-management; (2) standardize training between novice, intermediate and senior teachers; and (3) review the type and content of the program to have a better impact. Goodwin (2021) has defined the work definition of globalization and professionalism as a benchmark for teacher professionalism.



Day et al. (2023) in his study have suggested several practical approaches related to teacher professionalism namely: (1) expanding the concept of teacher professionalism by developing a local understanding of the perception and enactment of professionalism in different contexts across professions taking into account the role unique national and local cultural contexts; (2) designing initial teacher education and continuing professional development programs taking into account their influence on the professional ideals and individual identities of teachers, the interaction of ideologies and practical structures in the workplace, different socio-economic and economic geographic settings; (3) design a leadership development program that takes into account research on the association between the values, qualities and practices of school leaders on school culture and its impact on teachers' well-being and their capacity to embody professionalism and deliver optimal teaching experiences may be compromised.

1.2 Continuous Professional Development

The implementation of Continuous Professional Development (CPD) under Ministry of Education (MoE) was divided into several stages, namely planning, implementation, recording and awarding of the CPD credit point system. At the planning stage, the teacher Training Operation Plan is an effort by MoE to create a success systematic action of the Public Sector Human Resource Training Policy to ensure that teachers at all levels follow courses based on training needs analysis (Training Needs Analysis - TNA) (MoE, 2016).

TNA is an action that needs to be carried out before teacher plans any CPD activities. This analysis is used as a basis to determine the competencies that need to be developed. Needs analysis can be carried out through self-reflection, competency analysis, feedback from department heads, colleagues and the local community as well as training needs analysis instruments developed. Through self-reflection, teacher re-evaluates taking into account the needs of the service, self and organization in determining the form of training required.

In CPD activities, its implementation has been grouped into three initiatives, namely the Ministry, the organization and the individual. Through the individual CPD initiative, practices to cultivate self-directed learning and provide autonomy for the development of professionalism are driven through self-planning, self-regulating, self-assessment and self-improvement. Ahead of Wave 3 of the implementation of Malaysia Education Blueprint 2013-2025, the CPD activity approach gives priority to independent initiatives compared to organization-based CPD initiatives or ministry. The transformation of CPD practice requires teacher to plan and develop their own capabilities to be in line with Competency Standards and Performance Standards. The teacher professional development strategy has been used as a basis in the construction of the Training Road Map. On each career path, teacher will follow CPD categories which are basic, competency development, specific needs, electives and complements as shown in Table 1.

Table 1: Continuous Professional Development Category

CPD Category	Definition
Basic	Initial activities before or at the start of the teacher career path to master basic competencies and work orientation.
Competency Development	CPD activities to improve generic and functional competencies based on fields and job descriptions, career paths and grades.
Specific Needs	Program to improve teachers' competence in understanding, appreciating and implementing programs that support the



	implementation of the latest ministry policies or specific requirements.
Electives	Programs of one's own choice or according to the needs of the organization related to the field of work for the enrichment and strengthening of competencies to improve the delivery quality of service.
Complements	An exclusive program offered to top leadership and teachers and high-performing school leaders selected for the enrichment and strengthening of expertise and the development of towering personalities.

For this study, the CPD category involved is only for the “Basic Category”. This category is applicable to all teachers at all levels. While the rest of the next categories are subject to personal choice or according to the needs of the organization. Likewise with the complementary category which is an exclusive program for the highest leadership of teachers only.

Basic category is mandatory for newly appointed teacher with grade DG41. Initial activities at the start of the teacher career path are to master basic competencies and work orientation. For this study, the basic activity is divided into two aspects, namely setting goals and prioritizing self-confidence. These two important characteristics of self-concept are become the basis for motivation in the successful implementation of any activity according to Yahaya et al. (2005). Hashim et al. (2003) stated that a positive self-concept makes a person show positive attitudes and behaviours.

1.3 Setting Goals

An individual's motivation to do a job depends on his desire to achieve a goal (Locke, 1966). These goals represent actions to be taken and can be direct behaviour towards effective work performance. According to Locke and Latham (1990), the setting of this involved two factors which are efficiency and a person's commitment. Thus, a teacher needs to set goals to make them clear about what they want to achieve and expect. Teacher also needs to be aware of the challenges that they will face, form the necessary commitment towards achieving goals and gain the feedback that will be obtained from them.

In intrinsic motivation, a person's internal desire includes interest, curiosity and satisfaction which is a drive to do something without expecting or asking for a reward (Hussin, 2016). Teachers who have intrinsic motivation, will put themselves on a certain path to achieve an expected objective which the achievement that they will receive later is for their own satisfaction only. This is what forms a person's efficiency and commitment to a certain work, task and responsibility.

1.4 Prioritizing Self-Confidence

Self-belief is a trait possessed by a person with a sense of trust and confidence in his own abilities. It is able to well-planned all actions which leads to positive thinking in daily life. Teachers who have this confidence in carrying out their responsibilities will always use positive words, like to solve problems, use positive body language and introspect themselves.



Hassan and Musa (2020) stated that teachers indeed show commitment to change and improve their professionalism to a better level. He also added that teachers need to be responsible for improving and streamlining all dimensions of teacher professionalism through various means whether provided by the school, ministry or through their own efforts.

1.5 Objectives of the Study

Due to the importance of CPD for teachers, this study attempts to assess the CPD constructs in CPDI-IET and the items that are included in the construct are based on IET’s practices. Specifically, the research objectives of this study are as follows:

- a. To assess for model fit and reliability of Basic Constructs in CPDI-IET.
- b. To assess the convergent validity of Basic Constructs in CPDI-IET.
- c. To finalise the items obtained in Basic Constructs in CPDI-IET.

2. METHODOLOGY

2.1 Research Design

This study employed a descriptive research design using the survey method as our interest to obtain the CPD elements. IET responded to the survey to gather information about IET’s practice in CPD. In addition, the confirmatory factor analysis (CFA) was used to examine the underlying factor structure of the data. According to Schumacker and Lomax (1996); Wang and Ahmed (2004); and Byrne (2013), CFA is reckoned as a best-known statistical procedure for testing a hypothesized factor structure.

2.2 Sample

A total of 420 of IET from 63 secondary schools in Malaysia were selected to be involved in this study. They were selected based on a multistage sampling. Malaysia was divided into five zones which are Northern, Southern, Western, Central/Eastern, Southern and Sabah/Sarawak zones. Only three zones (Northern, Southern & Central/Eastern) selected for the first stage. For the second stage, two states were selected for each zone and for the third stage, two district of each state were selected as shown in Table 2. The instrument was administered to the samples in 63 secondary schools in Malaysia.

Table 2: Multistage Sampling Technique

Sampling (No)	First Stage (Zone)	Second Stage (State)	Third Stage (District)
1	Northern	Perak	Bagan Datuk Manjung
		Pulau Pinang	Seberang Prai Selatan Seberang Prai Tengah
2	Central/Eastern	Selangor	Klang Petaling Perdana
		Wilayah Persekutuan Kuala Lumpur	Bangsar/Pudu Sentul



3	Southern	Johor	Muar
		Negeri Sembilan	Segamat
			Seremban
			Port Dickson
Total	3	6	12

2.3 Instrumentation

The instrument named Continuous Professionalism Development Instrument – Islamic Education Teacher (CPDI-IET). A set of 5-point Likert scale (ranging from 1 = “Never” and “5 – “Always”) was administered to the samples. The samples were required to response to the 20 items of Basic Construct which may identify the CPD elements that are included based on IET’s practice.

The instrument comprised of two subconstructs of the Basic Construct that obtained from the related literature and documents. There were two subconstruct to assess Setting Goals (11 items) with Mean = 48.31 and Standard Deviation = 4.92 and Prioritizing Self-Confidence (9 items) with Mean = 38.72 and Standard Deviation = 4.37 that all included in CPDI-IET. Table 3 shows the instrument description.

Table 3: Instrument Description of Basic Construct

Name of Subconstruct	Total of Item	Number of Items	Mean	Standard Deviation
Setting Goals	11	142, 143, 144, 145, 146, 147, 148, 149, 150, 151 dan 152	48.31	4.92
Prioritizing Self-Confidence	9	153, 154, 155, 156, 157, 158, 159, 160 dan 161	38.72	4.37
Total	20			

2.4 Data Analysis

The measurement model will assess the degree and numbers of indicators representing a measured construct through CFA using Analysis of Moment Structures (AMOS) software. The CFA was tested for model fit, reliability and construct validity of the construct measured. To examine the model fit of this study, the CFA encompassed four indices namely TLI > 0.90, CFI > 0.90, RMSEA < 0.08 and Chisq/df < 5.0 and the factor loading should be above 0.5.

3. RESULT AND DISCUSSION

Figure 1 shows the measurement model for Continuous Professional Development with three constructs. Basic Construct as a latent variable with twenty observed variables were measured on the instrument with two subconstructs, Setting Goals and Prioritizing Self-Confidence.

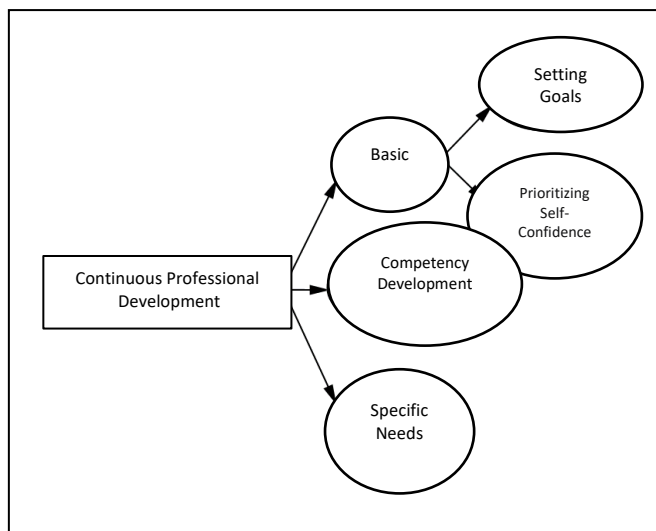

Figure 1: Measurement Model for Continuous Professional Development in CPDI-IET

3.1 Objective 1: To assess for model fit and reliability of Basic Construct in CPDI-IET using CFA

a. Setting Goals

Figure 2 presents the initial CFA for Setting Goals Construct which consisted of 11 items. The analysis showed poor fit (TLI = 0.91, CFI = 0.93, RMSEA = 0.10 and Chisq/df = 5.81) even though all factor loadings are more than 0.5.

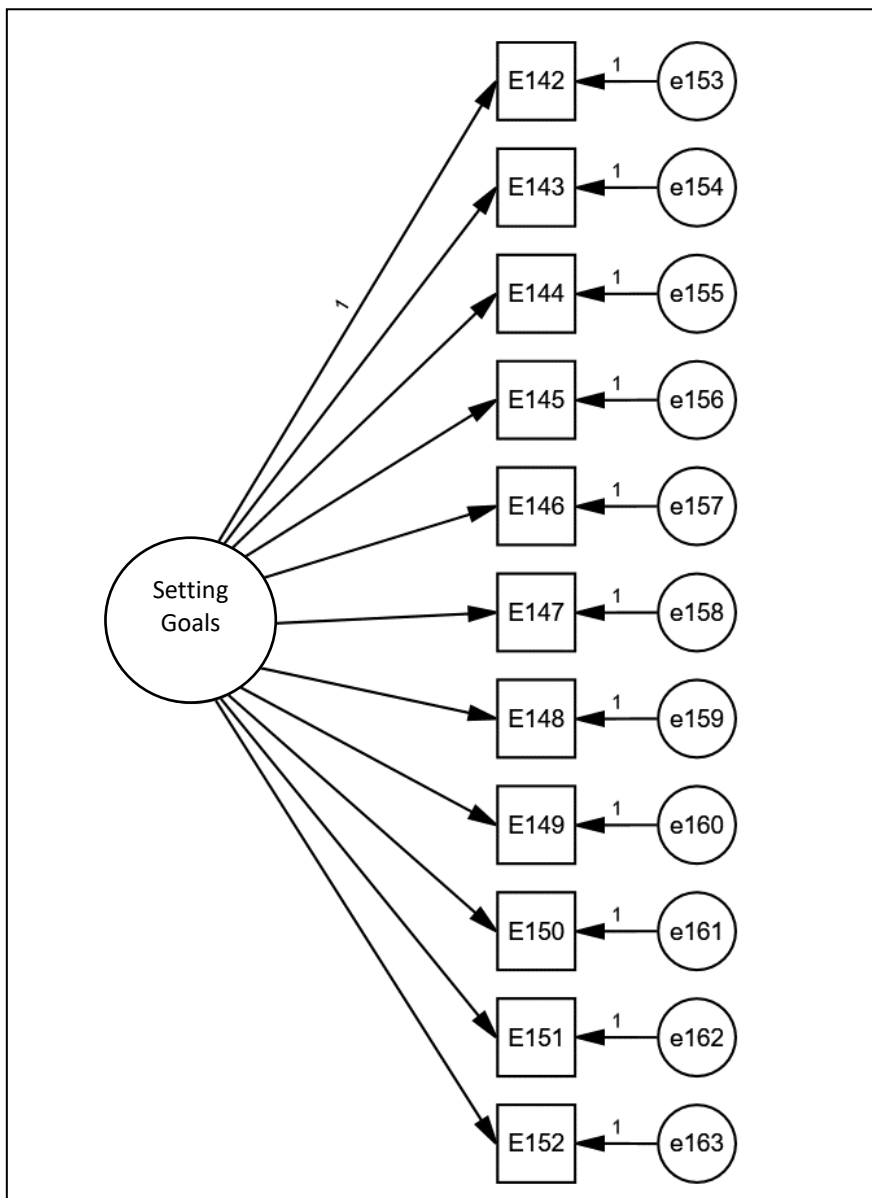

Figure 2: Measurement Model of Setting Goals

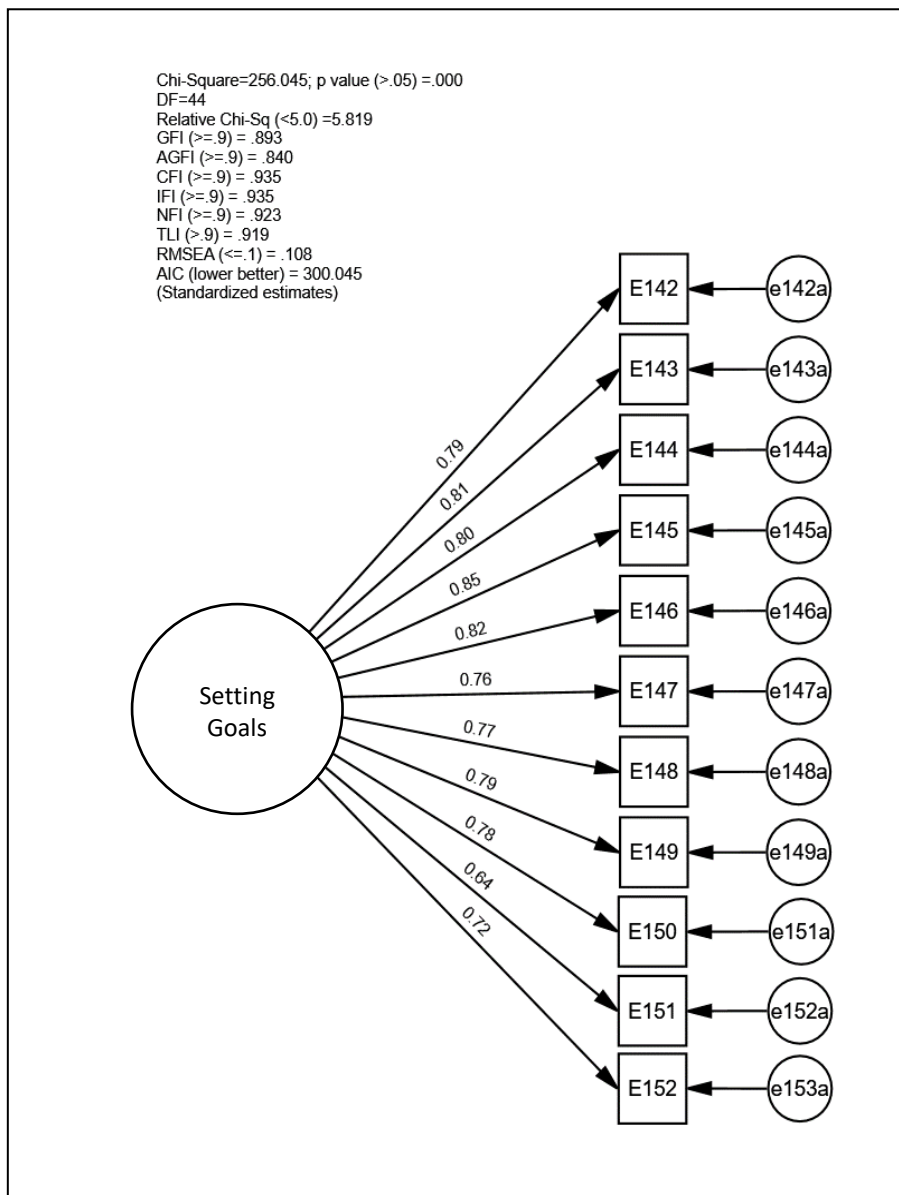

Figure 3: Initial Model of Setting Goals

Therefore, the researcher removed the items E150 to improve the fit of the model according to the modification indices (Figure 3). The revised model (Figure 4) with 10 items surpassed all the criterion values (TLI = 0.95, CFI = 0.96, RMSEA = 0.08 and Chisq/df = 4.17) and showed better fit with the data as shown in Table 4.

Table 4: Revised CFA Model Index Values for Goal Setting

Indicator	Index Value	Value Suggested	Result
RMSEA	0.08	<0.10	Good
GFI	0.93	>0.90	Good
CFI	0.96	>0.90	Good
TLI	0.95	>0.90	Good
Chisq/df	4.17	<5.00	Good

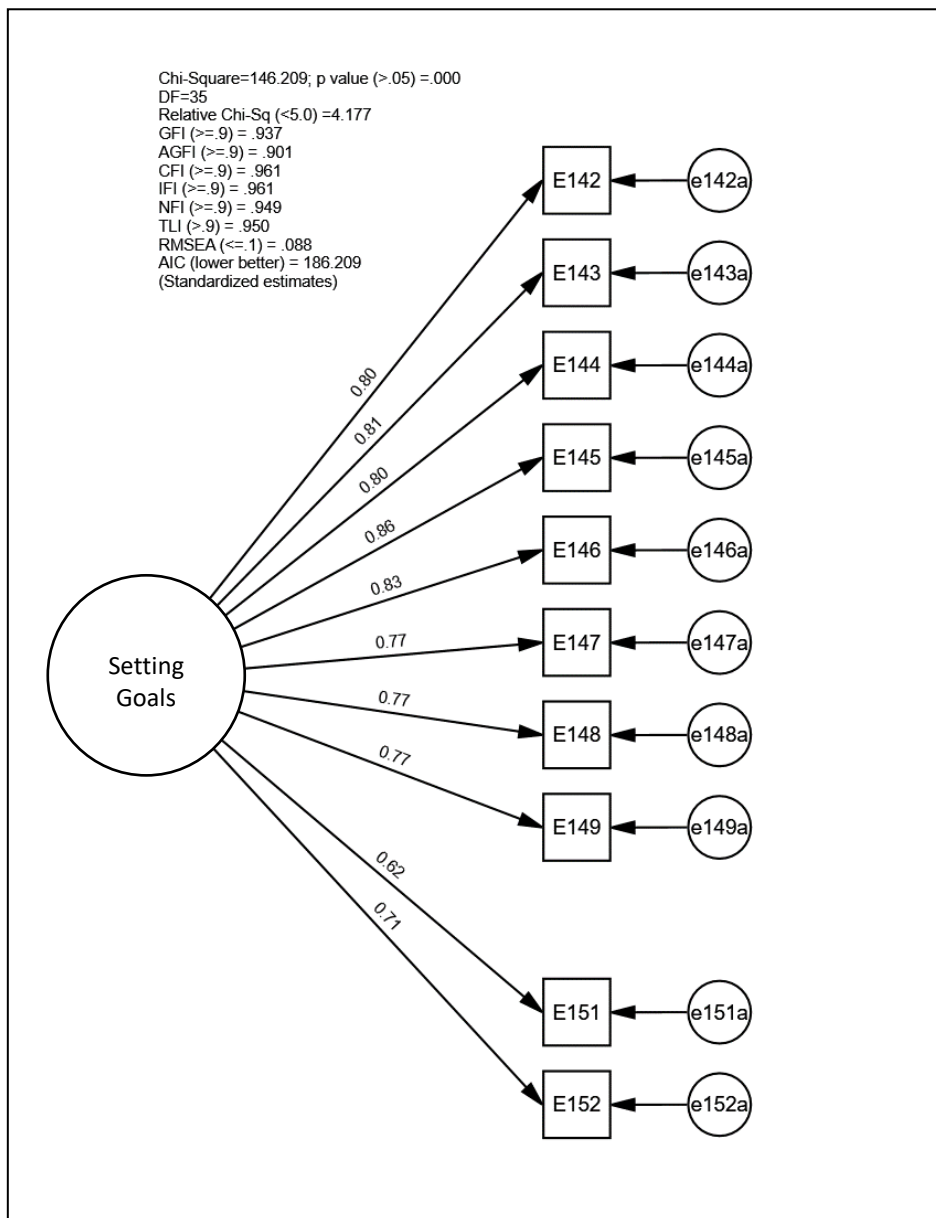

Figure 4: Revised Model of Setting Goals

b. Prioritizing Self-Confidence

Figure 5 presents the initial CFA for Prioritizing Self-Confidence Construct which consisted of nine items. The analysis showed poor fit (TLI = 0.81, CFI = 0.96, RMSEA = 0.18 and Chisq/df = 15.56) even though all factor loadings are more than 0.5.

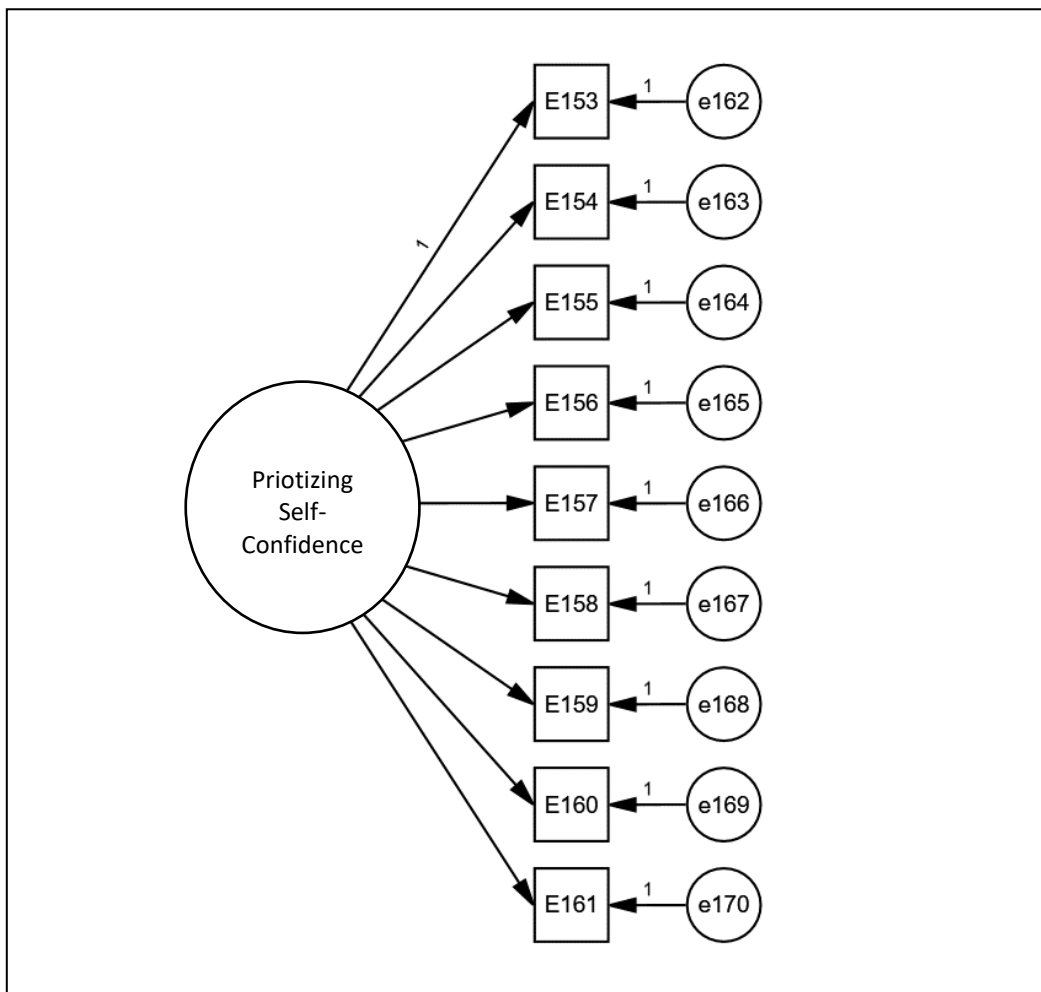

Figure 5: Measurement Model of Prioritizing Self-Confidence

Therefore, the researcher removed items E153, E154 and E155 one by one and covariances made between e167 with e170a in order to improve the model fit according to the modification indices (Figure 6). The revised model (Figure 7) with six items surpassed all the criterion values (TLI = 0.96, CFI = 0.98, RMSEA = 0.10 and Chisq/df = 5.39) and showed better fit with the data as shown in Table 5.

Table 5: Revised CFA Model Index Values for Prioritizing Self-Confidence

Indicator	Index Value	Value Suggested	Result
RMSEA	0.10	<0.10	Good
GFI	0.96	>0.90	Good
CFI	0.98	>0.90	Good
TLI	0.96	>0.90	Good
Chisq/df	5.39	<5.00	Good

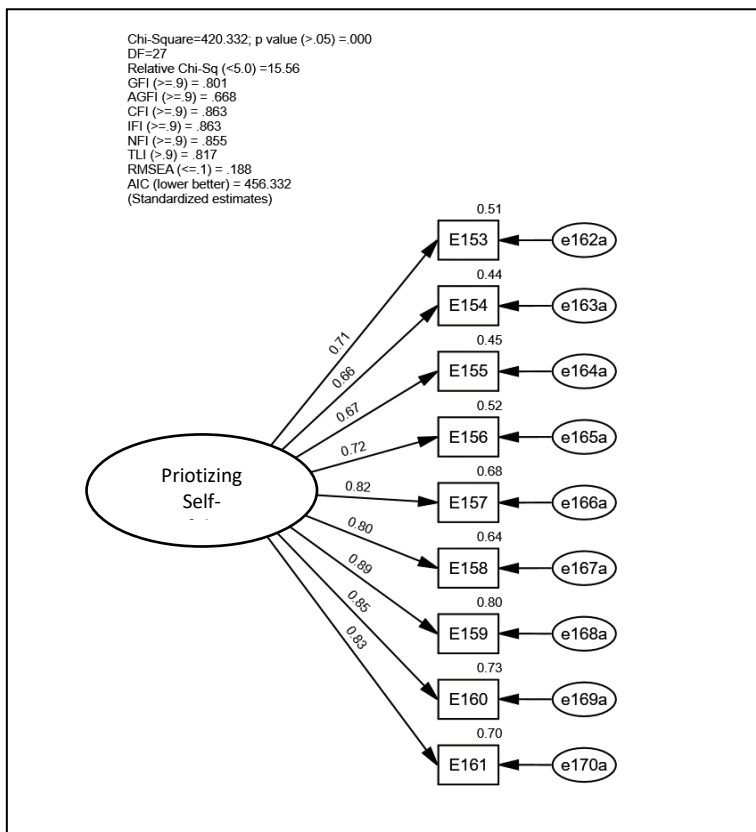

Figure 6: Initial Model of Prioritizing Self-Confidence

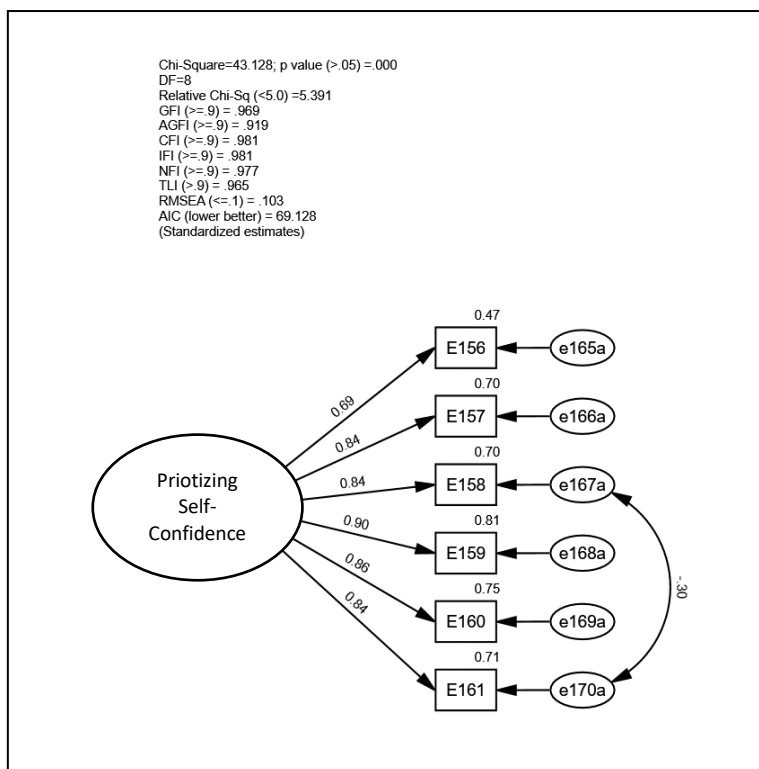

Figure 7: Revised Model of Prioritizing Self-Confidence



3.3 Objective 2: To assess the convergent validity of the construct using CFA

Convergent validity was achieved when all items in a measurement model are statistically significant. The convergent validity could be verified by computing the Average Variance Extracted (AVE) for every construct (Awang, 2014). The AVE measured exceeded 0.5 (0.77 & 0.82) and CR larger than 0.6 (0.93 & 0.92) indicating satisfactory validity and reliability (Fornell & Larcker, 1981; Bryne, 2010).

Furthermore, all items for Setting Goals and Prioritizing Self-Confidence were achieved high factor loadings which above ≥ 0.5 (Hair et al., 2010) as shown in Table 6 and Table 7. This is the evidence of convergent validity of the construct indicated that the items could measure the same traits.

Table 6: Loading Value, Average Value and Construct Reliability for Setting Goals

Item	Factor Loading	Average Value (AVE = > 0.50)	Construct Reliability (CR = > 0.60)
E142	0.80	0.77	0.93
E143	0.81		
E144	0.79		
E145	0.85		
E146	0.83		
E147	0.76		
E148	0.76		
E149	0.76		
E151	0.61		
E152	0.71		

Table 7: Loading Value, Average Value and Construct Reliability for Prioritizing Self-Confidence

Item	Factor Loading	Average Value (AVE = > 0.50)	Construct Reliability (CR = > 0.60)
E156	0.68	0.82	0.92
E157	0.83		
E158	0.83		
E159	0.90		
E160	0.86		
E161	0.84		

3.4 Objective 3: To finalise the items obtained in Basic Constructs in CPDI-IET

The analysis has yielded ten items of Setting Goals Construct which item E150 was deleted to improve the model fit as shown in Table 8. This items later retained in Basic Constructs for the final instrument of CPDI-IET. Meanwhile, the analysis has yielded six items of Prioritizing Self-Confidence Construct which item E153, E154 and E155 were deleted to improve the model fit as shown in Table 9.



Table 8: Final Items for Setting Goals Construct

Item	Description
E142	Carry out well-planned work.
E143	Use various strategies to achieve success.
E144	Have a goal.
E145	Smart planning.
E146	Take the initiative to improve self-performance.
E147	Strive to increase knowledge.
E148	Produce quality work within the set timeframe.
E149	Motivated.
E151	Trying to master the latest knowledge and skills. Example: TMK, research, writing, module development.
E152	Understand the responsibilities given.

Table 9: Final Items for Prioritizing Self-Confidence Construct

Item	Description
E156	Provide the best service to contribute towards school's excellence.
E157	Give thoughtful suggestions and ideas.
E158	Satisfied with self-achievement.
E159	Able to face challenges in various situations to achieve success.
E160	Dare to take risks and challenges.
E161	Be prepared to adapt to educational changes.

3.5 Discussion

The item E150 (*Trying to find a solution to the problem in a systematic way*) of Setting Goals Construct which was deleted because finding a solution to a problem requires certain knowledge and skills, not to mention if it is to be done systematically. Therefore, the item needs to be dropped in accordance with the proposed given. Likewise with items E153 (*Enthusiastic and active*), E154 (*Believe in one's own abilities*) and E155 (*Maintaining an open-minded approach to all situations*) of Prioritizing Self-Confidence Construct which were also dropped because these three items are more focused on the teacher's personality, not exactly for professional field.

Goodness of fit indices of CFA indicated a good fit of the collected data and the model. This indicated that the Basic Constructs was acceptable as the substantial element in CPD which is based on the requirement (Hair, 2010). Significantly, Basic Construct that included Setting Goals and Prioritizing Self-Confidence as part of basic needs of CPD that cannot be neglected. Nevertheless, the results also shown the empirical evidence of the reliability and validity of CPDI-IET.

4. CONCLUSION

This study provides an indication for the evidence of the important of Basic Construct as one of the elements in CPD that based on educational improvement on grounded empirical evidence in the context of actual practice. Based on the findings, teachers might be able to embed Setting



Goals and Prioritizing Self-Confidence items in daily practice and also assist educational authorities to plan CPD program for teachers, particularly by taking into consideration. The present study can be extended to different settings and sample in order to achieve a better measurement model. The validation of the CDPI-IET is anticipated more upcoming related issues will be conducted in the future in order to facilitate professional development practices. However, by considering triangulation in the current methodology, it gives more support in terms of measurement and evaluation of the instrument. This study is vital in Malaysian education since the scope of the teaching practices has changed which align with the technology development and the new educational trend.

REFERENCES

- Bryne, B. M. (2010) *Structural Equation Modelling with AMOS: Basic Concepts, Applications and Programming*, (2nd ed.), New York: Routledge, Taylor and Francis Group.
- Byrne, B.M. (2013) *Structural Equation Modeling with LISREL, PRELIS, and SIMPLIS: Basic Concepts, Applications, and Programming*, Hove: Psychology Press.
- Day, C. W., Simpson, A., Li, Q., Bi, Y., & He, F. (2023). Teacher professionalism: Chinese teachers' perspectives. *Journal of Professional Capital and Community*, 8(2), 65-89.
- Eliza, D., Sriandila, R., Fitri, D. A. N., & Yenti, S. (2022). Membangun Guru yang Profesional melalui Pengembangan Profesionalisme Guru dalam Penerapan Profesinya. *Jurnal Basicedu*, 6(3), 5362-5369.
- Fornell, C., Larcker, D.F. (1981). Evaluating structural equation models with unobservable variables and measurement error. *J. Mark. Res.* 18, 39–50.
- Goodwin, A. L. (2021). Teaching standards, globalisation, and conceptions of teacher professionalism. *European Journal of Teacher Education*, 44(1), 5-19.
- Hair, Joseph F., William C. Black, Barry J. Babin, and Rolph E. Anderson (2010), *Multivariate Data Analysis*, Englewood Cliffs, NJ: Prentice Hall.
- Hashim, S., Razali, M. & Jantan, R. (2003). *Psikologi Pendidikan*. Bentong, Pahang: PTS Publications & Distributor Sdn Bhd.
- Hassan, S. N. S., Tamuri, A. H., Othaman, I., & Mamat, M. S. (2009). Kajian persepsi pelajar terhadap tahap profesionalisme guru Pendidikan Islam MRSM. *JIAE: Journal of Islamic and Arabic Education*, 1(2), 31-50.
- Hassan, M. A. A., & Musa, K. (2020). The Relationship Between Professional Learning Community with Teacher Attitudes Towards Change. *International Journal of Academic Research in Business and Social Sciences*, 10(4).
- Hussin, H. (2004). *Learning to be reflective from theory to practices: Malaysia experiences*. Tanjong Malim: Penerbit Universiti Pendidikan Sultan Idris.
- Hussin, N. H. (2016). In *Pembangunan Profesionalisme Guru Pendidikan Islam*. Bangi: Kolej Universiti Islam Antarabangsa Selangor.
- Idris, N. H., & Hamzah, R. (2013). Nilai profesionalisme bakal guru berteraskan indicator Standard Guru Malaysia (SGM). *Sains Humanika*, 60(1).
- Ismail, R. A. R., & Ismail, D. (2018). Aplikasi 'Konsep 4C' pembelajaran abad ke-21 dalam kalangan guru pelatih pengajian agama Institut Pendidikan guru kampus Dato'Razali Ismail. *Asian People Journal (APJ)*, 1(1), 45-65.
- Jaafar, N. (2022). In *Model Pendidikan Islam Pembina Peradaban*. Kuala Lumpur: Institut Kefahaman Islam Malaysia.
- Jasmi, K. A., & Tamuri, A. H. (2015). Membudayakan Profesionalisme Guru Pendidikan Islam Yang Cemerlang. *Pemeriksaan Pendidikan Islam dalam cabaran zaman*, 1-20.



- Locke, E. A., & Latham, G. P. (1990). Work motivation and satisfaction: Light at the end of the tunnel. *Psychological science*, 1(4), 240-246.
- Locke, E. A. (1966). The relationship of intentions to level of performance. *Journal of applied psychology*, 50(1), 60.
- Malaysia Education Ministry. 2012. National Education Policy. Third Edition. Putrajaya: Education Policy Planning and Research Division, Ministry Malaysian education. <https://www.moe.gov.my/dasar/1196-bukudasar-kpm/file 20>.
- Malaysia Education Ministry. 2016. Teacher Education Development Master Plan. Putrajaya: Ministry of Education Malaysia.
- Muhammad, N. A. F. (2015). Pengaruh Tahap Kepercayaan Epistemologi Islam dan Tahap konsep sendiri Terhadap Amalan Pengajaran Guru Pendidikan Islam. Doctorate Dissertation. Universiti Kebangsaan Malaysia.
- Ramli, N. N. B., & Nor, M. Y. B. M. (2018). Pembelajaran Abad Ke-21. *Fakulti Pendidikan. Universiti Kebangsaan Malaysia*.
- Rashed, Z. N., Razak, S. R. A., Shahidan, N., Iksan, A. S. M. R. H., & Yusuf, S. A. M. Strategi Pengajaran Guru Pendidikan Islam Mengintegrasikan Ilmu Naqli Dan Aqli Menggunakan Pendekatan 'Lesson Study' Teaching Strategies of Islamic Education Teachers in Integrating Naql and Aql Knowledge Using 'Lesson Study' Approach.
- Schumacker, R. E., & Lomax, R. G. (2004). *A beginner's guide to structural equation modeling*. Psychology Press.
- Wang, C. L., & Ahmed, P. K. (2004). The development and validation of the organisational innovativeness construct using confirmatory factor analysis. *European journal of innovation management*, 7(4), 303-313.
- Yahaya, A., Yahya, F., Zakaria, Z. & Yahaya, N. (2005). Pembangunan Kendiri. Johor: UTM.
- Zabidi, N. F. M. & Yahaya, A. (2008). Persepsi pentadbir sekolah terhadap kualiti diri guru pelatih UTM di sekolah sekitar Johor Bahru. Doctorate Dissertation. Universiti Teknologi Malaysia.



096-064

STUDY ON THE COMPREHENSIVE PROMOTION EFFECT OF FUN TRACK AND FIELD ON CHILDREN'S PHYSICAL QUALITY

Zhu junhui

Universiti Kebangsaan Malaysia

Email: p126603@siswa.ukm.edu.my, Tel: 86-18428328170

Wang Ruonan

Universiti Kebangsaan Malaysia

Email: p127392@siswa.ukm.edu.my, Tel: 86-18948727835

ABSTRACT

The Ministry of Education released the Kindergarten Nursery Education Quality Assessment Guide in 2022. It emphasizes the need for kindergartens to develop and adapt physical exercise plans tailored to children's physical development, ensuring their health and holistic development. However, establishing an adaptive exercise program for children's physical development is a professionally intricate task, involving complex factors. Its design requires thorough theoretical consideration and comprehensive practical exploration. This paper employs literature review and expert interviews to extract elements of children's physical quality. These elements are then used to design fitness tests. Experimental and control classes (big and third classes, respectively) are established, with the former undertaking fun track and field courses and the latter participating in regular outdoor activities. Both classes undergo fitness tests before and after the intervention, with data analyzed using SPSS 26.0 for differentiation testing. The analysis reveals significant improvements in muscle endurance, rapid response ability, rapid explosive force, and upper limb strength among participants in the experimental class.

Keywords: Fun Track and Field, Children's Physical Fitness, Exercise Program, Differentiation Test.

INTRODUCTION

Fun track and field is a sports activity that combines traditional track and field events with creative game elements, aiming to promote children's physical development and comprehensive growth through engaging and imaginative track and field events. The design of this activity prioritizes fun and participation, seeking to spark children's interest and adapt to their age characteristics and physical abilities, allowing them to experience the joy of sports in a cheerful environment. Through this activity, children can enhance their physical fitness, improve coordination and balance, strengthen muscles, and foster a sense of competition and teamwork. The comprehensive promotional effect refers to the synergistic impact of various dimensions within an intervention or activity, where positive effects reinforce each other, resulting in a more significant and comprehensive outcome. This effect arises from the intricate interplay and interaction of different factors, surpassing the influence of any single factor. By intervening with engaging track and field sports, this paper demonstrates how children's



endurance, response, and coordination mutually enhance each other, collectively contributing to the enhancement of physical fitness.

1 Children's Physical Quality Elements Extraction

1.1 Literature Review for Identifying Children's Physical Quality Elements

After reviewing an extensive body of literature, the author systematically organized and condensed the components of children's physical quality. Unlike adults, children's physical quality emphasizes adaptation to daily activities and the promotion of physical development. Their physical development adheres to specific patterns. To identify these elements more effectively, the author synthesized the findings of four notable scholars and extracted the following components (refer to Table 1).

Table 1 Summary of the literature on young children's physical fitness

order number	Source	Content
1	Dai Ruilei (2012)	Speed quality, sensitive quality, lower limb muscle strength, coordination ability, Upper limb explosive force, lower limb explosive force, human flexibility, human balance ability
2	Yang Fang (2017)	Explosive quality, coordination quality, upper limb strength quality, balance quality, Flexible quality, reaction quality, balance quality
3	Liu Xiaoxia (2019)	Speed quality, sensitive quality, endurance quality, upper limb strength quality, flexibility quality
4	Liu Yubo (2020)	Sensitivity, flexibility, upper limb strength, balance, explosive force, coordination

1.2 Determination of Children's Physical Quality Elements

The literature review reveals a relatively unanimous understanding among scholars regarding children's physical quality at this juncture. They generally concur that children's physical quality comprises several dimensions, including speed, strength, endurance, flexibility, reaction time, balance, sensitive coordination, and explosive power. To ensure the accuracy of these elements, the author conducted an interview with Teacher Li, a physical fitness instructor at W Kindergarten. Through extensive communication and discussion with Teacher Li, practical observations and professional insights regarding children's physical quality elements were gathered. Subsequently, similar items were consolidated with those outlined in Table 1, retaining the most optimal expressions. As a result, seven distinct elements of children's physical quality were conclusively determined.

Through the sorting of literature and expert interview, guarantee to comprehensive physical assessment of children, determine the children's physical quality elements, including muscle endurance quality, rapid response ability quality, coordination quality, flexibility, balance,



lower limb explosive quality and upper limb strength quality, total seven, lay the foundation for follow-up research.

2 Pre-Child Physical Fitness Test

2.1 Test Content and Scoring Criteria

Based on the identified elements of children's physical quality, and with insights gathered from literature and discussions with physical fitness experts, specific test content has been established for each physical element. Additionally, scoring criteria have been delineated, with all test scores quantified on a scale of 1 to 5 points to facilitate subsequent research. The test content corresponding to each physical element is as follows:

Muscle endurance quality: 1-minute jump rope

Rapid response ability quality: 10-meter run

Coordination quality: Cross quadrant

Flexibility: Sitting body forward flexion

Balance quality: Crane balance

Lower limb explosive quality: Standing long jump

Upper limb strength quality: Tennis throwing

For specific details, please refer to Table 2.

Table 2 Content and scoring criteria of children's physical fitness test

Child physical quality elements	Test result (male)	Test result (female)	Value	Child physical quality elements	Test result (male)	Test result (female)	Value



1	Muscle endurance quality	1-minute rope skipping (a)	>64	>66	5	5	Balanced quality	Crane type balance (s)	>30.0	>32.5	5
			64-53	66-55	4				30-16.9	32.5-17	4
			52-32	54-34	3				16.8-11	16.9-11	3
			31-14	33-16	2				10.9-6	10.9-7	2
			>14	>16	1				<6.0	<7.0	1
2	Rapid response ability and quality	10 Meters Turn back to run (s)	<8.0	<8.2	5	6	Lower limb explosive force quality	halt long jump (cm)	>76	>71	5
			8.0-9.0	8.2-9.3	4				76-59	71-55	4
			9.1-10.2	9.4-10.5	3				58-43	54-40	3
			10.3-13	10.6-14	2				42-30	39-29	2
			>13.0	>14.0	1				<30	<29	1
3	Coordination quality	Cross quadrant jump (s)	<9.0	<9.5	5	7	Strength quality of upper limbs	tennis throw (m)	>5.5	>5.0	5
			9.0-10.5	9.5-11	4				5.5-4.0	5.0-3.5	4
			10.6-12	11.1-13	3				3.9-3.0	3.4-2.5	3
			12.1-14	13.1-15	2				2.9-2.0	2.4-1.5	2
			>14	>15	1				<2.0	<1.5	1
4	Flexible quality	Sitting body forward flexion (cm)	>12	>13	5						
			12-9	13-10	4						
			8.9-5	9.9-6	3						
			4.9-2	5.9-3	2						
			<2	<3	1						

In order to ensure standardized testing procedures, the author provides detailed explanations and descriptions for each test content:

1-Minute Skipping: Participants engage in continuous rope skipping for 60 seconds. This aerobic exercise aims to increase heart rate, enhance cardiopulmonary endurance, and engage the entire body's muscles.



10-Meter Return Run: A sprinting exercise where participants quickly return to the starting point after sprinting a distance of 10 meters on a straight track. This activity primarily assesses explosive power, acceleration, agility, and speed.

Cross Quadrant Jump: Participants perform a sequence of foot movements (0-1-0-2-0-3-0-4-0) on a cross quadrant mat. This exercise, completed in two cycles, aims to improve sensitivity and coordination.

Sitting Forward Flexion: A flexibility test and stretching exercise focusing on assessing spinal and lower limb flexibility. Participants sit on the ground with legs straight, bending forward to touch or reach their toes while keeping knees straight and toes upright.

Crane Balance: Participants balance on one foot while raising and bending the other, placing the foot close to the inner thigh of the standing leg. This pose, resembling a standing crane bird, enhances balance, stability, and body control.

Standing Long Jump: Participants execute a long jump from a stationary position, testing explosive power, strength, and technique.

Tennis Throwing: A test for assessing upper limb strength and basic movement abilities in young children (typically 3 to 6 years old). Participants throw a tennis ball to measure throwing distance, providing insights into strength and throwing skills.

2.2 Test Objects and Procedures:

To ensure the accuracy of the test data, the author selects a class and a third class from W Kindergarten in the Tianfu New District of Sichuan province as research subjects. After preliminary investigation, both classes consist of 35 students, with similar fitness test results. Therefore, the author designates one class as the experimental group and the other as the control group. Additionally, two class teachers are invited to assist with testing to ensure data authenticity and reliability. Testing is conducted over two days of outdoor activities, totaling four class hours, with the author supervising while the class teacher serves as the main tester.

2.3 Test Data Collation:

Collected data are organized and categorized into samples from the experimental and control groups. Descriptive analysis is performed using SPSS 26.0 to analyze maximum, minimum, and average values for both groups. Detailed data are presented in Table 3.

Table 3 Descriptive statistical analysis of pre-fitness test data

	experime				Control				
	ntal class	experime	experime	experime	class	Control	Control	Control	
The	ntal class	ntal class	ntal class	ntal class	The	class	class	class	
number	least	crest	average	average	number	least	crest	average	
of cases	value	value	value	value	of cases	value	value	value	
One	minute	35.00	1.00	5.00	3.13	35.00	1.00	5.00	2.91
skipping rope									
Turn	back	1035.00	1.00	5.00	2.75	35.00	1.00	5.00	2.95
meters									



Cross quadrant jump	35.00	1.00	5.00	3.64	35.00	2.00	5.00	3.57
Sit forward	35.00	2.00	5.00	3.51	35.00	1.00	5.00	3.25
Crane balance	35.00	2.00	5.00	3.63	35.00	2.00	5.00	3.46
standing long jump	35.00	1.00	5.00	2.53	35.00	1.00	5.00	2.63
Tennis throwing	35.00	1.00	5.00	2.41	35.00	1.00	5.00	2.26
Number of valid cases (in a column)	35.00				35.00			

Results indicate that the test scores for both the experimental and control groups fall within a range from less than 3.00 to a maximum of 5.00, with averages exceeding 2. However, the average scores for the 10-meter run, standing long jump, and tennis throwing in the experimental group are less than 3.00. Similarly, in the control group, the average scores for rope skipping, the 10-meter run, standing long jump, and tennis throwing are less than 3.00.

3 Fun Track and Field Course Implementation

3.1 Course Design

The design of this engaging track and field course is a collaborative effort between primary school physical education teachers and professional child fitness instructors. This comprehensive course spans 32 sessions and adheres to principles of safety, age appropriateness, diversity, and enjoyment (refer to Table 4).

Safety: While specific safety principles are not outlined in the course plan, ensuring safety is paramount during instruction. It is imperative to maintain a safe environment and supervise children's activities closely during physical education courses.

Age Appropriateness: The course plan considers the age characteristics of children, selecting simple and enjoyable activities suitable for children aged 3-6.

Diversity: The course curriculum encompasses a wide range of sports activities, including running, long jump, high jump, throwing, and rope skipping, among others, to enhance course diversity. Additionally, the course incorporates comprehensive competitions and mini marathons, utilizing a combination of activities to promote holistic child development.

Enjoyment: The course plan integrates elements of fun and games, fostering a cheerful atmosphere during activities to ensure that children maintain a joyful mood throughout the course.

Table 4 Fun track and field course plan

Class time	content of courses	Class time	content of courses
1	Basic posture and skills for running and sprint	17	Balance exercises with sitting posture forward flexion exercises
2	Sprint race	18	Learn the basic skills of skipping rope
3	relay race	19	skipping rope game
4	Learn the basic movements and	20	Comprehensive competition



5	skills of the long jump Long jump competition	21	exercises Comprehensive competition competition
6	Learn the basic movements and skills of the high jump	22	Small-range mini-marathon practice
7	high jump competition	23	Fun mini-marathon course design
8	Learn the basic skills of throwing light objects	24	A full-fledged mini-marathon race
9	Hurling competition	25	Sports and sports small games
10	Learn the basic skills of throwing tennis balls	26	Running exercises and sprint games
11	Throw tennis match	27	Turn back to run practice
12	Fun practice for the obstacle course	28	Balanced ball competition
13	Handicap competition	29	Agile ladder practice
14	Comprehensive competition practice	30	Long jump practice and competition
15	Comprehensive competition	31	Throwing practice and competition
16	Sports games and group activities	32	Comprehensive competition and awards

3.2 Course implementation

Sichuan Tianfu New District W Kindergarten has an outdoor activity course from Monday to Friday morning and afternoon, which lasts for 50 minutes. The experimental class selects the outdoor activity course from Monday to Friday afternoon to carry out interesting track and field courses, and controls the normal outdoor activity course, with 4 class hours per week for a total of 8 weeks. The implementation of the course is mainly implemented by the class director, and the author records it as the supervisor and the instructor in real time.

4. Post-hoc physical fitness test and data analysis

4.1 Descriptive Analysis

Following the 8-week period of the engaging track and field course, the author conducts post-test physical assessments in the 9th week for both the experimental and control groups. The test content remains consistent with the initial physical fitness test, including 1-minute jump rope, 10-meter return run, cross quadrant jump, sitting body forward flexion, crane balance, standing long jump, and tennis throwing, totaling seven tests. Descriptive analysis of the test results is conducted, with specific data provided in Table 5.

Table 5 Descriptive statistical analysis of post-conditioning physical fitness test data

experime				Control			
ntal class	experime	experime	experime	class	Control	Control	Control
The	ntal class	ntal class	ntal class	The	class	class	class
number	least	crest	average	number	least	crest	average
of cases	value	value	value	of cases	value	value	value



One minute skipping rope	35.00	3.00	5.00	4.04	35.00	1.00	5.00	3.15
Turn back 10 meters	1035.00	2.00	5.00	3.45	35.00	2.00	5.00	3.14
Cross quadrant jump	35.00	2.00	5.00	3.85	35.00	2.00	5.00	3.63
Sit forward	35.00	2.00	5.00	3.53	35.00	1.00	5.00	3.25
Crane balance	35.00	2.00	5.00	3.74	35.00	2.00	5.00	3.55
standing long jump	35.00	2.00	5.00	3.21	35.00	1.00	5.00	2.83
Tennis throwing	35.00	3.00	5.00	3.37	35.00	2.00	5.00	2.48
Number of valid cases (in a column)	35.00				35.00			

4.2 Significance Analysis

Data collected from both pre- and post-physical fitness tests were collated and subjected to t-tests using SPSS 26.0. In the experimental group, scores for each physical element were analyzed independently, while in the control group, the total average of the seven physical elements was calculated. Specific statistical results are presented in Table 6.

Table 6 Statistical results of physical fitness test results

class	Experimental class pre-test	Control with the class pre-test	P	Experimental class post-test	Control with the class post-test	P
One minute skipping rope	3.13 ± 2.2		=.852 >.05	4.04 ± 1.1		=.013 <.05 **
Turn back 10 meters		3.01 ± 0.8			3.15 ± 0.7	
Cross quadrant jump	2.75 ± 2.3		=.623 >.05	3.45 ± 1.5		=.035 <.05 *
Sit forward	3.64 ± 2.7		=.368 >.05	3.85 ± 1.9		=.238 >.05
Crane balance	3.51 ± 2.6		=.463 >.05	3.53 ± 1.6		=.157 >.05
standing long jump	3.63 ± 2.7		=.358 >.05	3.74 ± 1.8		=.197 <.05
Tennis throwing	2.53 ± 2.5		=.417 >.05	3.21 ± 1.3		=.047 <.05 *
	2.41 ± 2.6		=.295 >.05	3.37 ± 1.7		=.337 <.05

Note: * is significant and ** is very significant



From the previous physical fitness test, the P-values of the seven tests between the experimental class and the control class were greater than 0.05, indicating no significant difference. In the post-fitness test, the P-values for cross quadrant jump, tennis throwing, sitting body forward flexion, and crane balance in both the experimental and control classes were greater than 0.05, indicating no significant difference in these four items. However, for the 10-meter return run, standing long jump, and 1-minute jump rope, the P-values were less than 0.05, indicating a significant difference. Specifically, the 10-meter return run and standing long jump, as well as the 1-minute jump rope, showed very significant differences.

4.3 Comparative Analysis of Data Before and After Experiment and Control Classes

In addition to the horizontal comparison between the experimental and control classes, vertical comparison is also necessary. The average scores of the experimental and control classes are extracted to establish the pre-test average (X1) and post-test average (X2). The scores are then compared, and the percentage increase is calculated. Specific information is presented in Table 7.

Table 7 Comparison of difference scores between experiment and control class

Class	X1	X2	promote	Increase the percentage rate
One minute skipping rope	3.13	4.04	0.91	29.07%
Turn back 10 meters	2.75	3.45	0.70	25.45%
Cross quadrant jump	3.64	3.85	0.21	5.77%
Sit forward	3.51	3.53	0.02	0.57%
Crane balance	3.63	3.74	0.11	3.03%
standing long jump	2.53	3.21	0.68	26.88%
Tennis throwing	2.41	3.37	0.96	39.83%
Experimental class average	3.09	3.60	0.51	16.50%
Compare the class average	3.01	3.15	0.14	4.65%

As observed from the table above, the highest improvement rates were recorded for tennis throwing, 1-minute rope skipping, standing long jump, and 10-meter return running, at 39.83%, 29.07%, 26.88%, and 25.45%, respectively. On the other hand, the improvement rate for cross quadrant jump was 5.77%, crane balance was 3.03%, and sitting position was 0.57%.

4.4 Study Conclusion

Through saliency analysis (i.e., horizontal comparison), it is evident that the intervention of the engaging track and field course has led to significant improvements in various aspects of physical quality for the experimental class compared to the control class. Specifically, the experimental class exhibited a very significant improvement in muscle endurance quality, significant improvements in rapid response ability and rapid explosive quality, and certain



enhancements in balance quality, coordination quality, flexibility, and upper limb strength quality.

Through comparative analysis of before and after data (i.e., longitudinal comparison), it is concluded that the intervention of the engaging track and field course has significantly improved muscle endurance ability, rapid response ability, rapid explosive ability, and upper limb strength quality in the experimental class compared to 8 weeks prior.

CONCLUSION

Fun track and field is a popular activity in current times and has proven effective in enhancing children's physical quality. This study, spanning over 5 months, meticulously prepared, intervened, and analyzed data, utilizing horizontal and longitudinal comparisons to evaluate the positive impact of fun track and field on children's physical quality. The findings suggest that while certain test projects exhibit characteristics related to physical elements, others also require specific skills. For instance, the improvement observed in the 1-minute rope skipping and tennis throwing tests did not solely rely on physical elements but also on skill acquisition. Future research should consider consciously intervening to minimize skill-related influences on experimental results. In summary, children's physical exercise should integrate both physical and mental development aspects, and fun track and field plays a significant role in promoting children's physical activity. This study, based on empirical research, aims to explore the comprehensive promotion effect of fun track and field on children, with the aspiration of offering beneficial insights for children's physical exercise development.

REFERENCES

- Liu Yubo. Study on the influence of physical training in children aged 4-5 years [D]. Harbin Normal University, 2020.DOI:10.27064/d.cnki.ghasu.2020.000658.
- Yang Fang. Experimental study on the effects of physical training on cognitive ability and physical fitness in young children aged 5-6 years [D]. Chengdu Physical Education Institute, 2020.DOI:10.26987/d.cnki.gcdtc.2020.000051.
- Liu Xiaoxia. The effect of physical training on physical fitness in children aged 3-4 years [D]. Fujian Normal University, 2019.DOI:10.27019/d.cnki.gfjsu.2019.000903.
- Xu Fang. Promote children's physical development and improve children's overall quality [J]. Popular science fairy tale, 2019 (08): 174.
- Dai Ruilei. Research on physical quality development of children aged 3~6 years old in Jining city [J]. Journal of Jining University, 2012,33 (03): 83-86.
- Zhou Zhifeng. Experimental study on the effect of track game training on physical fitness of children aged 4-5 years [D]. Guangzhou University, 2022.DOI:10.27040/d.cnki.ggzdu.2022.001350.
- Huang Pengyong, Pu Lijuan. Analysis of the method of developing children's fun track and field sports in kindergarten [J]. Contemporary sports technology, 2021,11(36):197-199.DOI:10.16655/j.cnki.2095-2813.2111-1579-8737.



091-067

ANALYSIS OF CURRICULUM NEEDS BASED ON LOCAL PROBLEMS (SADONG JAYA DISTRICT)

Abg. Ashmirul Bin Abg. Abu Nawas
Fakulty of Education, Language dan Communication,
Pre University Study Centre,
Universiti Malaysia Sarawak.
aanaashmirul@unimas.my

Karem Bin Wahab
SMK Pesantren Abdul Taib Mahmud

Masaraie Bin Nabari
Pejabat Pendidikan Daerah Sri Aman.

Zainal Abiden Bin Abdul Rasid
Penolong Pegawai
Pejabat Pendidikan Daerah Sarikei
Unit Pendidikan Islam

ABSTRACT

Sadong Jaya was previously a small district under the administration of Derah Simunjan and from January 1, 2002, Derah Kecil Sadong Jaya has become a small district under the administration of Asajaya. which is located between Batang Samarahan and Batang Sadong. The population still rely on the agricultural sector as their main source of income. This study aims to analyse the curriculum needs of residents in the Sadong Jaya district based on local problems. This study is a qualitative study where the researcher obtains local background through data stored at the Sadong Jaya Subdistrict Office, crime and health statistics. In addition, an interview session was held with a local representative to obtain his opinion and views towards the problems faced by the local population. After analyzing the data collected, the researchers indicate that there are 5 main elements of the curriculum for residents in the Sadong Jaya district, which are elements to overcome social problems, elements to improve health, elements to expand the exposure of English language in daily life, element to increase skills in technical fields and element to further increase the understanding of religious knowledge.

Keywords: Curriculum Needs, Local Problem, Sadong Jaya.



004-076

**NEEDS ANALYSIS FOR DEVELOPMENT OF SCIENCE LABORATORY
EDUCATIONAL COMIC ON IMPROVING SCIENCE LABORATORY SAFETY
AWARENESS AMONG SECONDARY SCHOOL STUDENTS**

Nur Farha Shaafi
Faculty of Psychology and Education
Universiti Malaysia Sabah, 88400 Kota Kinabalu, Malaysia
Email: farhashaafi@ums.edu.my, Tel: 014-8330648

Mohamad Mubarrak Mohd Yusof
Faculty of Education
Universiti Teknologi MARA, 42300 Puncak Alam, Malaysia
Email: mubarrak@uitm.edu.my, Tel: 013-3007859

ABSTRACT

In the study of design and development, one of the vital stages that need to be carried out is the needs analysis. In this study, a needs analysis is carried out to ensure that the module produced is suitable for the user's needs. This quantitative survey study was carried out to see the need for the development of the science laboratory educational comic on improving science laboratory safety awareness among secondary school students as well as to see students' awareness and knowledge towards science laboratory safety. A set of needs analysis questionnaires was given to 131 secondary school students throughout Malaysia. The data obtained were analyzed descriptively, such as frequencies and percentages using Statistical Package for Social Science version 23.0 software. The results of the analysis show that the majority of respondents agree that this module is suitable for science laboratory safety awareness. A moderate level of average mean score of 3.53 also indicate that the level of awareness of regulations in the laboratory among average students is still low and needs to be improved. A high average mean score of 3.90 of respondents agreed that the development of science laboratory safety educational comic should be developed to improve science laboratory safety awareness among secondary school students. Majority of respondents agreed that emphasis should be placed on content and technical approaches in educational comics to develop a science laboratory safety educational comic that suits the needs of students, with a high average mean score of 3.73. The results of this study provide a brief overview of the need for a science laboratory educational comic on improving science laboratory safety awareness among secondary school students.

Keywords: Educational Comics, Science Laboratory Safety, Awareness, Needs Analysis.



095-099

**THE INFLUENCE OF L2 MOTIVATIONAL SELF SYSTEM ON THE
WILLINGNESS TO COMMUNICATE AMONG CHINESE UNDERGRADUATE
STUDENTS IN ENGLISH MEDIUM INSTRUCTION CLASSROOMS**

Wang Ruonan

Universiti Kebangsaan Malaysia

Email: p127392@siswa.ukm.edu.my, Tel: 86-18948727835

Dr. Nur Ehsan Mohd Said

Universiti Kebangsaan Malaysia

Email: nurehsan@ukm.edu.my, Tel: 60-134514514

Zhu junhui

Universiti Kebangsaan Malaysia

Email: p126603@siswa.ukm.edu.my, Tel: 86-18428328170

Zhang Wenyu

Universiti Kebangsaan Malaysia

Email: p131781@siswa.ukm.edu.my, Tel: 86-15552673309

ABSTRACT

This study adopts a case study approach to investigate the impact of the L2 motivational self system on Chinese undergraduate students participating in English Medium Instruction (EMI) programs. Through individual case analyses within authentic environments, the research explores how the ideal L2 self and external pressures influence students' willingness to communicate and decision-making processes in EMI settings.

Three participants engaged in EMI programs were interviewed via the Tencent Meeting platform. The study employed NVivo software for qualitative data analysis. The results indicate that the ideal L2 self plays a crucial role in shaping students' willingness to communicate in EMI classrooms. Students with a clear ideal L2 self demonstrate higher levels of participation and engagement, driven by their desire to bridge the gap between their current English proficiency and their ideal level. Furthermore, external pressures, such as family expectations and career aspirations, contribute to the formation of the ought-to L2 self. While these pressures enhance students' motivation to improve their English skills, they may also induce anxiety and reluctance to participate, stemming from the fear of negative evaluation. Additionally, the ought-to L2 self strongly influences students' decisions to enroll and actively engage in EMI programs. While EMI programs align with students' personal and professional goals, individual differences in self-concept lead to variations in communication willingness among students.

In conclusion, the study highlights the complex interplay between the L2 motivational self system and students' communicative behavior in EMI contexts. Addressing both self-concept and external influences is crucial for promoting effective participation and language development among students in EMI programs. These insights contribute to enhancing language learning environments and pedagogical practices in EMI settings.



Keywords: Willingness to Communicate, The L2 Motivational Self System, English Medium Instruction (EMI), The Ideal L2 Self, The Ought-to L2 Self.

INTRODUCTION

With the acceleration of globalization, more and more non-English speaking countries are introducing bilingual education in their higher education systems. Among them, English Medium Instruction (EMI) is one kind of teaching method. English Medium instruction (EMI) is 'to use English to teach non-English academic subjects (apart from English itself) in countries or jurisdictions where the majority of the population's first language (L1) is not English' (Macaro, 2018,18), for example, using English to teach non-English disciplines like Chemistry, Economics, Management in Chinese higher education.

As the rapid expansion of EMI has taken place around the world, the number of EMI projects in mainland China (hereafter China) has also been experiencing rapid growth, especially in Chinese higher education (Gao and Ren, 2019). In 2001, China joined the World Trade Organization (WTO). Since then, Chinese economy started to globalize and internationalize, so as to Chinese education, with various top-down and bottom-up initiatives promoted and implemented to reform education at all levels and to achieve the goal of quality education (Hu, 2021). With the purpose of promoting the internationalization and globalization of Chinese higher education, improving Chinese universities' reputation and enhancing their international competitiveness in the world (Brown, 2014), Chinese Ministry of Education (CME) gradually started to introduce EMI projects, proposing a plan to create 500 national-level EMI courses in Chinese higher education in 2007. In addition, it also aims to improve domestic college students content knowledge and English proficiency at the same time, so as to enhance their core competitiveness and international perspective (Brown, 2014). Although EMI in China is relatively new and this system is not mature enough compared with some European countries where EMI projects have developed for a longer time, CME has been providing financial support and policy support and encouragement for Chinese universities to develop more EMI projects (Hu, 2019).

However, students' willingness to communicate (WTC), (which refers to an individual's readiness and inclination to initiate and participate in communication in a given language or context) in EMI context is rather low in China. Therefore, this study aims to explore the relationship between the L2 Motivational Self System (as defined by Dornyei, 2009) and the willingness of Chinese undergraduate students to communicate in EMI classrooms, and accordingly offer some possible implications to improve Chinese college students' low motivation and low willingness to use English to communicate in EMI program.

DESIGN OF THE STUDY

This research focus on the research questions as follows.

1. How does the ideal L2 self (as defined by L2 motivational self system) influence the willingness of Chinese undergraduate students to actively communicate in English Medium Instruction (EMI) programs?
2. How do external pressures shape the ought-to L2 self within the L2 Motivational Self System?



3. How does the ought-to L2 self within the L2 Motivational Self System influence Chinese undergraduate students' decision to enroll and actively communicate in English Medium Instruction (EMI) programs?

Context

EMI programs in Chinese higher education institutions are divided into two categories: partial EMI and full EMI. This research focuses on partial EMI programs, also known as the 'Multilingual Model' of EMI (Macaro, 2018). In this context, not the entire curriculum is delivered in English; however, students are mandated to enroll in a minimum of one EMI course per semester.

Participants

An EMI course on the topic of International Finance offered at a Department of Economics at Southwest Minzu university in China will be chosen as the site for data collection. A total of three students who are enrolled in EMI courses in the School of Economics participated in this research. Of the three students, one is male and two are females. The participants were from the same major in the School of Economics, majoring International Finance, but with different level of English proficiency. After obtaining the signed consent forms showing their willingness to join the study, the participants completed an online structured interview about their willingness to communicate and actively engage in EMI classrooms.

	English level	Gender	Major	
Interviewee 1	Higher	Male	International Finance	
Interviewee 2	Medium	Female	International Finance	
Interviewee 3	Lower	Female	International Finance	

Table 1: basic information of participants

This setting was deemed appropriate for the study because:

- The course was taken in the students’ second semester instead of the beginning of university course, allowing them to become adapted to university-style assessments, and minimizing the transition effects noted in previous research (Rose *et al.*, 2019, cited in Evans and Morrison, 2011)
- The International Finance course was the first EMI program taken by the students in the university, thus minimizing the effect of previous experiences on EMI academic success
- Participants in this course were all Chinese domestic students, minimizing the effect of first language differences on success in EMI
- All students came from the same school and attended the same lectures given by the same course lecturer, thereby minimizing the effect of different teachers’ pedagogical approaches on students’ willingness to communicate in EMI classrooms



DATA COLLECTION

A case study approach will be employed to investigate the dynamics of the L2 motivational self system among Chinese undergraduate students in English Medium Instruction (EMI) programs. The study will concentrate on individual cases within their real-world settings. This approach is ideal for exploring how the ideal L2 self and external pressures shape students' willingness to communicate and their decision-making processes in EMI programs.

As an EMI program is context-specific, a single case-study will be chosen for this study to eliminate context-related confounding variables affecting success related scores (Rose *et al.*, 2019).

DATA ANALYSIS

In this study, three qualitative interviews to explore the influence of the L2 Motivational Self System on students' willingness to communicate in EMI classrooms. The data collected during the interviews were transcribed and analyzed using NVivo software.

The first step is data transcription. The initial phase of the research involves transcribing the three qualitative interviews word-for-word, meticulously capturing every spoken word, pause, and non-verbal cue. This detailed transcription forms the foundation for the analysis that follows. Prior to transcribing, I have to check the quality of the interview recordings for clarity to ensure all elements are precisely captured. An iPhone and a voice-to-text software were employed for swift and accurate transcription. The goal of this step is to maintain the integrity and fullness of the interviews, which is critical for precise data analysis. After the initial transcription, a thorough review is conducted to verify the accuracy of the transcribed text.

The second phase involves initial coding, focusing on extracting insights about the students' experiences and emotions in EMI programs. This step entails importing the word-for-word transcribed texts into NVivo. Each interview is assigned a distinct project or folder within NVivo for efficient management and differentiation. The process then moves to open coding of these texts, where essential words, phrases, or sections are highlighted and assigned codes using NVivo's coding feature. Additionally, nodes are created for each code, with sub-nodes being added as needed to further categorize and refine the data.

The third step is theme identification. After completing preliminary coding, conduct an in-depth analysis of the transcribed texts to find recurring patterns, concepts, or ideas. Identify patterns and themes that emerge from the coded data. This involves analyzing coded data for each theme, understanding how they relate to your research questions, and interpreting the meanings behind them.

The fourth step is an in-depth analysis of the identified themes, exploring their relationship to the research questions. Analyze the specific content within themes, and then link the results of the analysis with the purpose and questions of the study. Interpret the findings in the context of my research questions and the existing literature. Discuss how the themes and patterns contribute to understanding the research problem.



RESEARCH FINDINGS

I firstly developed word clouds with Nvivo for the three interviewees' answers to represent the frequency of words they have mentioned. It can be useful for quickly identifying prominent themes or concepts in my data. They can provide a visual summary of the most frequently used words in your interviews or other text sources.

Here are specific interpretations of the word cloud regarding three research questions.

Regarding RQ1, the frequent appearance of terms like "speak," "fluency," and "discussions" across the word clouds suggests a strong willingness to communicate in English. This reflects the students' ideal L2 self, highlighting a desire to actively improve and use English, which aligns with the goals of EMI programs.

To answer RQ2, words such as "expectations," "career," "pressure," and "academic" indicate the presence of external pressures influencing students' language learning experiences. These terms point towards a relationship between the students' ought-to self and the external demands of academic performance and future career aspirations within the context of EMI.

To answer RQ3, the prominence of "EMI," "English," "learning," and "improve" suggests that the students' decisions to enroll and communicate in EMI are driven by the desire to meet their ought-to self. The word clouds imply a clear link between students' language self-concept and their proactive engagement in EMI classes to enhance their English proficiency.

Figure 1: Word cloud regarding RQ1



Figure 2: Word cloud regarding RQ2





名称	材料来源	参考点
Preparation and Preview	1	1
Class Participation Motivation	1	2
Ideal L2 Self	1	5
Fluency in English	1	2
Confidence	1	2
Communication with Foreigners	1	1
Clarity of Expression	1	2
Academic Reading Comprehension	1	1
Expected vs. Actual Participation in EMI Courses	1	1
Expectations for Using English	1	1
Actual Speaking Situations	1	1
EMI Courses and Long-term Objectives	1	2
International Perspective	1	2
Career Goals	1	1
Academic Goals	1	1
Behavior and Decision in EMI Courses	1	1
Understanding of Professional Knowledge	1	1
Course Selection	1	1
Classroom Performance	1	1
Balancing English Learning Goals with External E	1	1
Setting Small Goals	1	1
Managing Pressure	1	1
Family Communication	1	1

Regarding RQ1: Influence of Ideal L2 Self on Willingness to Communicate in EMI

Interviewee 1 demonstrated a strong connection between the perception of an ideal English learner and the willingness to communicate in EMI settings. Specific experiences were highlighted where striving towards this ideal motivated active classroom participation. Interviewee 2 discussed his efforts to engage in classroom discussions, driven by the ideal L2 self-image, and also highlighted personal strategies to overcome discomfort in English communication. Interviewee 3 focused on improving English proficiency for academic and career goals, illustrating how the ideal L2 self influenced his active engagement in EMI contexts.

For perception of Ideal English learner, each interviewee had a distinct image of their ideal L2 self, often linked to fluency and confidence in English. More importantly, this perception was a driving force behind their active participation and communication efforts in EMI classrooms. Just as interviewee 1 mentioned:

‘So, for me, the ideal English learner must not only have a solid foundation in the language, but more importantly, the ability to apply English in practice. Such capabilities can help us better understand the world and also give us more of a voice on the international stage. I’ve been trying to move in this direction myself. Although I am still not in the ideal state in my mind, I believe that through continuous learning and practice, I will get closer and closer to this goal.’

For experiences of active English usage, the narratives shared by the three interviewees reflected experiences where their ideal L2 self-motivated them to use English actively, overcoming barriers like fear of making mistakes or feeling less proficient than peers. Although they feel stressed because they want to achieve their ideal L2 self, it motivates them to speak more in EMI class. For example, interviewee 3 whose English is not so good has mentioned:

‘To be honest, my English isn’t very good, so I often feel a bit overwhelmed in class. Sometimes, I want to contribute, but fear of making mistakes and being laughed at by classmates holds me back, so I don’t have the courage to try. Seeing some classmates who speak English so well makes me wish I could do the same. This thought sometimes depresses me



because I feel that I am still far from that ideal state. On the other hand, it also makes me think I should work harder. Although I know I can't reach that ideal overnight, I still try to listen more and take more notes in class, hoping to keep up. Sometimes, I also try to answer simple questions. Although it might not be very fluent, I feel it's a learning process, right? I hope that by continuously striving, I can gradually become more confident in EMI classes.'

Also, the interviewee 1 whose English is good has mentioned:

'This ideal image has really had a big impact on my participation in English Medium Instruction classes. First, it gave me a clear goal and let me know what direction I was going to work towards. I always wanted to be the kind of learner who could understand complex academic content and express my opinions fluently. This kind of purpose motivates me to be more proactive in my classes.'

Regarding RQ2: Role of External Pressures in Shaping the Ought-to L2 Self

Interviewee 1 mentioned external pressures such as family and career aspirations were significant in shaping the English learning motivations. These pressures are as key motivators influencing the participation in EMI programs. Interviewee 2 discussed balancing personal goals with external expectations, particularly from family and career perspectives. This balance influenced the learning attitude and classroom behavior. Interviewee 3 highlighted the influence of career goals on the decision to enhance English skills. They described external pressures as a driving factor for the proactive approach in EMI classes.

Family expectations and academic requirements are as key components shaping their Ought-to L2 self. Three interviewees discussed how family expectations and academic pressures shaped their ought-to self, influencing their English learning motivations and strategies for improving proficiency. Family expectations and academic pressures do have an obvious influence on their Ought-to L2 self. For example, interviewee 1 has mentioned:

'First of all, family expectations are a big factor. I come from a family that values education very much, and my parents always emphasized the importance of English in the era of globalization.'

Also, she has mentioned academic requirements,

'As a student of international economics, I am well aware of the importance of English in this field. Most of the professional books and articles are in English, and international conferences and discussions are largely conducted in English. This means that good English proficiency is essential if I want to succeed academically. This academic need for English is constantly pushing me to improve my language skills.'

For peer influence, from the answer of three participants, I can conclude that comparisons with peers also played a role in shaping the ought-to self, as interviewees felt motivated to match or surpass their peers' English proficiency levels. Just as interviewee 2 said:

'Additionally, my environment, like the choices of other students in the university and the suggestions from teachers, also influenced my decision to some extent. Seeing many



classmates actively participating in EMI courses and benefiting from them made me feel like I should do the same.’

Regarding RQ3: Impact of Ought-to Self on Decision to Enroll and Communicate in EMI Programs

Interviewee 1’s decision to enroll in EMI was influenced by a desire to meet external expectations and personal aspirations, viewing EMI as a platform for language improvement and career advancement. Interviewee 2 emphasized that enrolling in EMI was part of a strategy to be more competitive in international fields, highlighting the role of external motivations in the learning choices. Interviewee 3 described EMI participation as crucial for personal and academic development, influenced by the ought-to self and reflecting on the challenges and rewards of EMI experiences.

Regarding their motivations for enrolling, the decision to enroll in EMI programs was linked to external pressures and personal aspirations, reflecting the influence of the ought-to self. Interviewees saw EMI as an opportunity to bridge the gap between their current abilities and desired proficiency. As interviewee 3 said:

‘While these external pressures can sometimes make me feel anxious and nervous, they more often motivate me to be more proactive and engaged in EMI classes. These challenging experiences gradually help me adapt and improve my English proficiency and academic abilities.’

As for classroom engagement and communication strategies, the strategies used by interviewees in the classroom, such as participating in discussions or group projects, were influenced by their desire to align with the ought-to self. For example, interview 3 mentioned:

‘It encourages me to attempt speaking in English more, even when I may hesitate, worrying that my language isn’t fluent enough or my pronunciation is not accurate. Nevertheless, I strive to overcome these concerns because I know it will help improve my English proficiency.’

And interviewee 2 mentioned:

In EMI courses, I feel that I "should" participate and try to communicate in English as much as possible, even if my English level is not very high. I think I should try my best to understand the course content, even though it sometimes might require extra effort. I also think I should actively speak in class, even if it's just simple questions or answers, because it's an opportunity to improve my English skills.

CONCLUSION

The analysis of the interviews suggests that the Ideal L2 Self has a significant impact on the willingness of Chinese undergraduate students to communicate in English Medium Instruction (EMI) classrooms. Students who have a well-defined Ideal L2 Self are more inclined to actively participate in EMI programs, seeking to close the gap between their current proficiency and their desired level of English mastery.



External pressures, such as familial expectations and career aspirations, are found to shape the Ought-to L2 Self, compelling students to adhere to certain behavioral standards in EMI environments. These pressures often lead to increased motivation to improve their English, but may also contribute to anxiety and reluctance to participate when students fear negative evaluation.

Lastly, the Ought-to L2 Self appears to strongly influence students' decisions to enroll and actively engage in EMI programs. The alignment of EMI programs with their personal and professional goals encourages students to use these programs as a platform to meet the standards set by their Ought-to L2 Self. However, the extent to which this self-concept influences communication willingness varies, indicating that individual differences play a crucial role in language learning motivation.

These findings underline the complex interplay between the L2 Motivational Self System and the communicative behavior of students in EMI contexts, highlighting the importance of addressing both self-concept and external influences to foster effective participation and language development.

REFERENCES

- Gardner, R. C., & Lambert, W. E. (1972). Attitudes and motivation in second-language learning.
- Horwitz, E. K. (1986). Preliminary evidence for the reliability and validity of a foreign language anxiety scale. *Tesol Quarterly*, 20(3), 559-562.
- MacIntyre, P. D., Clément, R., Dörnyei, Z., & Noels, K. A. (1998). Conceptualizing willingness to communicate in a L2: A situational model of L2 confidence and affiliation. *The modern language journal*, 82(4), 545-562.
- Ryan, R. M., Kuhl, J., & Deci, E. L. (1997). Nature and autonomy: An organizational view of social and neurobiological aspects of self-regulation in behavior and development. *Development and psychopathology*, 9(4), 701-728.
- Macaro, E. (2018). *English medium instruction*. Oxford University Press.
- Jablonkai, R. R., & Hou, J. (2023). English medium of instruction in Chinese higher education: A systematic mapping review of empirical research. *Applied Linguistics Review*, 14(6), 1483-1512.
- Hu, G. (2021). English language policy in Mainland China: History, issues, and challenges. *English in East and South Asia: Policy, features and language in use*, 19-32.
- Brown, H., & Bradford, A. (2014). EMI, CLIL, & CBI: Differing approaches and goals. *The use of English*, 37.
- Hu, G. (2019). English-medium instruction in higher education: Lessons from China. *Journal of Asia TEFL*, 16(1), 1.
- Dörnyei, Z. (2009). The L2 motivational self system. *Motivation, language identity and the L2 self*, 36(3), 9-11.
- Mullins, C. H., Boyd, C. J., & Corey, B. L. (2020). Examining the correlation between altmetric score and citations in the general surgery literature. *Journal of Surgical Research*, 248, 159-164.
- Lee, J. S. (2020). The role of informal digital learning of English and a high-stakes English test on perceptions of English as an international language. *Australasian Journal of Educational Technology*, 36(2), 155-168.



- Reynolds, B. L., Xie, X. S., & Pham, Q. H. P. (2022). Incidental vocabulary acquisition from listening to English teacher education lectures: A case study from Macau higher education.
- Iyengar, S. S., & Lepper, M. R. (1999). Rethinking the value of choice: a cultural perspective on intrinsic motivation. *Journal of personality and social psychology*, 76(3), 349.
- d'Ailly, H. (2003). Children's autonomy and perceived control in learning: A model of motivation and achievement in Taiwan. *Journal of Educational Psychology*, 95(1), 84.
- Vansteenkiste, M., Simons, J., Lens, W., Sheldon, K. M., & Deci, E. L. (2004). Motivating learning, performance, and persistence: the synergistic effects of intrinsic goal contents and autonomy-supportive contexts. *Journal of personality and social psychology*, 87(2), 246.
- Evans, S., & Morrison, B. (2011). Meeting the challenges of English-medium higher education: The first-year experience in Hong Kong. *English for Specific Purposes*, 30(3), 198-208.



125-103

THE VIEWS OF PRIMARY SCHOOL TEACHERS TOWARDS MATH SYLLABUS FOR UPPER STANDARDS

Muhammad Shafiq Bin Zul
School of Education and Human Sciences
Albukhary International University, 05200 Kedah, Malaysia
Email: Shafiq.zul@student.aiu.edu.my, Tel: 011- 2192 6560

Aini Syahira Binti Jamaluddin
School of Education and Human Sciences
Albukhary International University, 05200 Kedah, Malaysia
Email: aini.jamaluddin@aiu.edu.my, Tel: 013- 447 2605

ABSTRACT

Malaysia is classified as a developing nation. As an example, these can be seen in the progress of the school system towards 21st century education. As the school system grows, each subject is enhanced and reinforced at higher levels, particularly in mathematics. The history of mathematics indicates that whenever a civilization placed a high value on mathematical ability, it made remarkable progress. Mathematics is one of the most important cognitive tools that we possess, and vital as it is the foundation of many disciplines and imperative for building modern civilization. However, this also elicits concern among educators and learners, since students encounter challenges in understanding the subjects included in the advanced curriculum. Hence, this study aims to study the views of primary school teachers in Malaysia towards math syllabus for upper standards. A series of interviews were carried out to get the in-depth data from six of primary school educators instructing at upper standards by using rigorous thematic analysis. This study utilized qualitative analysis to identify several obstacles, strengths, and areas for improvement, as seen by elementary school teachers in relation to the mathematics syllabus for the upper standard. Key themes identified include, the current KSSR Mathematic syllabus is challenging, students are incapable of empowering the basic Math skills, students are not interested in learn the current topic of mathematics, the current KSSR Math's syllabus is preparing students to face real-world challenges and the use of technology affects student performance.

Keywords: Standard Curriculum for Primary Schools (SCPS), Mathematic Teachers, Primary School.

INTRODUCTION

Mathematics is a fundamental subject that plays a crucial role in molding the cognitive growth of students. The study of mathematics provides students with the fundamental knowledge and analytical abilities necessary for success in any enforcement, since it cultivates advanced cognitive and problem-solving capabilities. In Malaysian context, the mathematics subject syllabus experienced a change in 2017, including secondary school themes into the elementary school syllabus. These include mathematics, measures and angles, data management, and other



topics. This reform is a progressive move towards fostering 21st century learning by assessing and developing students' critical thinking abilities. Even so, not only students but the teachers also find mathematics to be a challenging and daunting topic. Students who struggle with math in primary school are more likely to struggle in later years (Importance of Teaching Math in Primary School Solutions and Strategies, n.d.). So, this study was conducted to explore the experience of teachers in teaching this new mathematics syllabus to primary school students, especially for upper standards. This study also focuses on what are the challenges faced by teachers in ensuring student understanding in teaching this new mathematics syllabus.

Teacher competence is important in ensuring that the delivery of a lesson is effective (Nurul & Roslinda, 2020). Understanding the views of primary school teachers towards the mathematics syllabus for upper standards is crucial for several reasons. Firstly, it provides valuable insights into the suitability and effectiveness of the current curriculum in addressing the diverse learning needs of students. Secondly, it sheds light on potential areas of improvement or reformulation within the syllabus to enhance its comprehensibility and relevance. Furthermore, exploring primary school teachers' perspective and experiences on the mathematics syllabus for upper standards is imperative in the context of emerging educational trends, technological advancements, and evolving pedagogical methodologies. As the educational landscape continues to evolve, it is essential to ensure that the mathematics curriculum remains dynamic, responsive, and aligned with the needs and expectations of both teachers and students. Therefore, this research aims to investigate the views of teachers' experiences towards the mathematics syllabus for upper standards. By conducting a comprehensive analysis of teachers' perspectives, this study seeks to identify strengths, weaknesses, challenges, and opportunities associated with the current curriculum.

Thus, the study aims to explore the teacher's experience in teaching the current mathematics syllabus for upper standards and the challenges faced by the primary school teachers in teaching the current mathematics syllabus.

LITERATURE REVIEW

LOCATION OF SCHOOLS AND TEACHERS' EXPERIENCES

In a study conducted by Nurul and Roslinda (2020) on Primary School Teachers' Specialized Content Knowledge and Self-Efficacy in Teaching Fraction Topic, it was found that the factors of school location and teaching experience have a notable impact on the specialized content knowledge self-efficacy of school teachers when it comes to teaching the topic of fractions. One factor that may contribute to student achievement is the school's location, whether it is in an urban or rural area, as well as the teacher's level of experience. The efficacy of a learning and facilitation session (PdPc) depends upon the teacher's mathematics pedagogical content understanding. Acquiring knowledge for effective teaching can equip instructors with the tools to enhance the organization and structure of their instruction (Dahlam & Muhammad, 2022). To address this aspect, instructors should get assistance in the form of advice, namely through information exchange with more seasoned educators (Nurul and Roslinda, 2020). This is because possessing optimal particular topic knowledge enables instructors to effectively analyze and break down the mathematical curriculum, resulting in the development of high-quality student abilities.



BASIC SKILLS IN MATHEMATICS

Jehana M Darkis (2020) study in Zamboanga City and Sulu Province on the Views and Challenges in Teaching Mathematics of Elementary Teachers in Rural and Urban School Districts found that basic math skills ranked second in the view of teachers in rural areas with an average mean of $M=4.45$, compared to teachers in urban areas with an average mean of $M=4.09$. The outcomes of this study indicate that fundamental math abilities play a crucial role in a student's development, and it is recommended that these skills be introduced to youngsters as early as preschool. This is due to its ability to facilitate students' comprehension of advanced mathematical principles and provide them with practical problem-solving skills. Basic skills are necessary to advance in math (Tom, 2003). For instance, this includes tasks such as calculating the duration required to complete a task, determining the quantity of products needed, making purchases and sales in stores and cafeterias, and calculating bus tickets, among other things.

THE USE OF TEACHING MATERIALS

According to the study conducted by Mohd Suhaimi bin Omar, Noor Shah Saad, and Mohd. Uzi Dollah (2017), table 6 reveals that elementary school mathematics teachers face a shortage of time to prepare teaching materials. This issue is indicated by the highest mean value of 4.00. Therefore, the teaching aids are a useful tool for students to comprehend complex mathematical topics, such as fractions. According to Suhaimi et al. (2017), a proficient teacher possesses the ability to effectively utilize instructional resources, demonstrating both expertise in designing such materials and a comprehensive understanding of individual variances. The central role of textbooks and other learning and teaching materials (LTM) in enhancing the quality of learning and improving student performance is widely recognized (Smart & Jagannathan, 2018). The objective for using teaching aids in the teaching and learning process is to enhance the clarity of information presentation, avoiding excessive reliance on verbal communication and effectively utilizing the limited space available.

METHODOLOGY

This research is mainly focused on the views of primary school teachers about the mathematics syllabus for upper standards. Additionally, a qualitative research design appears to be the most suitable approach to achieve the objective of this inquiry. Case studies are employed to acquire comprehensive insights into the subject matter. Data on the topic was collected through interviews with a total of 6 mathematics teachers.

In this study, a total of six mathematics teachers who teach upper standards were interviewed to ensure that the findings and results of this research are accurate and reliable. All the respondents are teachers at Sekolah Kebangsaan Convent, Alor Setar, Kedah.

The characteristics of the respondents are as follows:

- Mathematics school teachers
- The teaching experience is at least five years
- The respondents are including female and male teachers
- The respondents are teaching in upper standards (Standard 4,5 and 6)



Table 1: Biography of the respondents

Respondents	Gender	Years of Teaching	Grade
A	Male	5	Standard 6
B	Female	20	Standard 5
C	Female	23	Standard 6
D	Female	19	Standard 6
E	Female	27	Standard 5
F	Female	6	Standard 5

The interview is being held physically and interview sessions are being videotaped and transcribed to provide evidence and ensure transparency of the conducted interviews. Each participant is provided with the exact same set of questions that address the two research objectives.

The data for this study were acquired through an interview session, where all interviewers were given a set of questions. Therefore, the interview session performed with these six respondents was meticulously recorded, transcribed, and organized in a systematic way.

THEMES OF FINDINGS

The interview that was conducted has resulted in a few themes including the prior theme set beforehand of the study.

The theme are as follows:

- I. The current KSSR Mathematic syllabus is challenging
- II. Students are incapable of empowering the basic Math skills
- III. Students are not interested in learn the current topic of mathematics
- IV. The current KSSR Maths syllabus is preparing students to face real-world challenges.
- V. The use of technology (smartphones) affects student performance

RESULTS AND FINDING

The Current KSSR Mathematic Syllabus is Challenging

All respondents in this research mentioned and agree that the current Math’s syllabus is difficult for students to understand because it requires higher-order thinking skills.

Respondents A:

“... High level learning and basic skills such as addition, subtraction, multiplication and division that students cannot master. When the level is too high, it reduces students' interest in learning. For example, you can see in the answers of this exam, when it involves KBAT questions, the students are too lazy to think and do not answer anything.”



Respondents B:

“... This syllabus, after revision in 2017, the syllabus for upper standard has been increased. So, the upper standard syllabus for students is now more and more challenging.”

Respondents C:

“... There is too much for students to master, for example, the breakdown of many topics with a short time constraint to finish the syllabus.”

Respondents D:

“... The topic is increasing; the students' skills are also increasing when compared to the previous syllabus. However, there is a deficiency that the teacher can see, because when the topics increase, the students become less interested in mastering the topics and the students quickly forget.”

Respondents E:

“... My opinion is based on past experience. I think the current syllabus is too high, too high for upper standard primary school students, which is grade 4 to grade 6.”

Respondents F:

“... More challenging and the teacher's burden is also getting bigger, because of different changes. This high syllabus gives the effect of dropping out to students and affects the development of students.”

The results of the interview are in line with the research conducted by Ramiro Z. dela Cruz and Gloria D. Hernande (2023) in Challenges of public-school elementary mathematics teaching in the new normal in which there is a high level of challenge that is felt in all factors from curriculum adjustment, alignment of materials, the orientation of parents or guardians and teachers' training.

Through this study, it can be concluded that there are several challenges faced by teachers in teaching students in the subject of mathematics.

Students Are Incapable of Empowering the Basic Math Skills

Three out of six respondents in this research mentioned and agreed that the students are incapable of empowering the basic Math skills when they involve sentence-based mathematics questions.

Respondents A:

“... if the basics are not mastered, the student cannot multiply or divide and when it comes standard 6, and answers questions involving KBAT then the student cannot do it.”

Respondents D:

“... When it comes to problem solving questions, students don't know what operations to use for the questions, they read.”

Respondents E:

“... Want to understand and master basic skills, for example ciphers, students become lazy to memorize.”



Based on the findings of the study, it shows that students cannot fully master the basic skills in mathematics. According to research from Ruzlan Md-Ali, et al. (2021) in his study Issues and Challenges of Mathematics Teaching and Learning in Malaysian Indigenous Primary Schools from The Teacher's Perspective states that they can successfully solve sums involving basic operations and in symbolic form. However, they usually find it difficult to negotiate the linguistic density of long items in mathematical word problems.

Students Are Not Interested in Learning the Current Mathematics Topics

Three out of six respondents in this research mentioned and agreed that the students are not interested and too lazy in learning the new Mathematics topic because it requires a lot of memorizing.

Respondents A:

“... When the level is too high, it reduces students' interest in learning. For example, you can see in the answers of this exam, when it involves KBAT questions, the students are too lazy to think and do not answer anything.”

Respondents D:

“... Attract students' interest and by wanting to remember all the topics of the lesson, sometimes because there are too many topics, students are too lazy to remember and quickly forget.”

Respondents E:

“... Student attitude is lazy and not interested in learning. The problem now is when there is no exam, like before there was UPSR, now when there is no exam and only based on PBD, students are too lazy to study and are more exposed to the world of entertainment.”

Based on the findings of the study, students do not care about their learning and do not strive to learn new things. According to K. Abdul Gafoor and Abidha Kurukkan (2015) in their study Learner and Teacher perception on Difficulties in Learning and Teaching Mathematics: Some Implications shows that the most relevant reason observed by teachers for students' difficulties in learning mathematics is lack of sufficient effort by students, and they were not that much aware about the role of students' self-efficacy for learning mathematics. So, what can be seen is the lack of self-efficacy and interest as the main reason for not taking the effort in learning mathematics.

The Current KSSR Maths Syllabus Is Preparing Students to Face Real-World Challenges.

Three out of six respondents in this research mentioned and agreed that the current KSSR Maths syllabus is preparing students to face real-world challenges.

Respondents B:

“... For example, in the topic of money literacy, students are exposed to cash purchases, debit, credit and are also exposed to savings, compound interest, simple interest and what is debt, what is credit and how to invest”

Respondents C:

“... This new syllabus is also good for elementary students to use in secondary school”



Respondents E:

“... When students go out into the outside world, they need those skills, so it's been taught from elementary school and it's a good thing.”

Based on the findings of the study, with the new syllabus students can apply the knowledge gained in learning to real world situations. According to Alia (2021) in his study What is the Latest Mathematics KSSR Year 6 Test Format said that in order to survive in the real world as well as when the student reaches the point to enter the working environment, they need to be an all -rounder and equipped with more skills in both career and living skills.

The Use of Technology Affects Student Performance

Two out of six respondents in this research mentioned and agreed that the use of technology such as smartphones affects students' performance.

Respondents C:

“... Students are exposed to a lot of gadgets, causing them to lack focus in learning mathematics. In fact, students can find answers using gadgets but do not make the best use of them.”

Respondents E:

“... Students are more exposed to the world of entertainment, for example watching TikTok, influenced by influencers, K-pop and artists. So, students are more interested in the world of entertainment and in terms of learning they are less.”

However, there are only few outcomes from the findings of this study and it contradicts the research conducted by Poçan et al., (2022). As cited from Poçan et al., (2022), highlighting the flexibility of time and space provided by mobile applications to students and stating that students are more successful in mathematics when used in mobile applications, (Al Khateeb, 2019). So, parents need to control the use of mobile phones and ensure that their children take advantage of the use of the technology as best as possible.

CONCLUSION AND DISCUSSION

This research provides useful insights into the perspectives of primary school teachers on the mathematics curriculum at higher grade levels. Primary school educators clearly realize the need of a strong mathematics curriculum in developing students' fundamental knowledge and preparing them for advanced mathematical topics. On the other hand, they raise questions about whether the accuracy of the present curriculum is appropriate, understandable, and relevant to students' diverse educational needs. This study indicates that the research has important consequences for curriculum design, teaching methods, and professional training programs in elementary mathematics education. Educational policymakers and curriculum developers can use elementary school teachers' insights to improve and update the mathematics syllabus for upper elementary levels. By integrating teachers' viewpoints, the curriculum may be enhanced to better address the varied requirements of students, making it more relevant, comprehensive, and efficient. By engaging in joint efforts and continuous conversation, stakeholders may cooperate to establish a favourable and encouraging learning environment that enables every student to build a solid foundation in mathematics. Further research is needed to comprehend



primary school teachers' views on the advanced mathematics curriculum, and efforts should be made to improve the quality and efficiency of basic mathematics instruction.

REFERENCE

- Abd Algani, Y.M. (2022). *Role, Need and Benefits Of Mathematics In The Development Of Society*. Journal for the Mathematics Education and Teaching Practices, 3(1), 23-29.
- Amaral, D., Tomé, A. O., Da Costa, A., & Goncalves, S. (2023, July 26). Factors Affecting Student's Interest In Learning Mathematics. ResearchGate.
- Dela Cruz, R. Z., & Hernandez, G. D. (2023, June 16). *Challenges of public-school elementary mathematics teaching in the new normal*. Indonesian Journal of Social Sciences, 15(1), 8–20. <https://doi.org/10.20473/ijss.v15i1.40340>
- Gafoor, K, A, & Kurukhan. A. (2015, December 21 & 22). *Learner and Teacher perception on Difficulties in Learning and Teaching Mathematics: Some Implications*, <https://files.eric.ed.gov/fulltext/ED568368.pdf>
- Loveless, T. (2003, September 1). *Trends in Math: The Importance of Basic Skills*. Brookings. <https://www.brookings.edu/articles/trends-in-math-the-importance-of-basic-skills/>
- Md-Ali, R., Veloo, A., Suppiah Shanmugam, S. K., Jusoh @ Yusoff, Y., & Awang-Hashim, R. (2021). *The Issues And Challenges Of Mathematics Teaching And Learning In Malaysia Orang Asli Primary Schools From Teachers' Perspectives*. Malaysian Journal Of Learning And Instruction, 18. <https://doi.org/10.32890/Mjli2021.18.2.5>
- Nizam, N, A. & Rosli, R. (2020). *Pengetahuan Isi Kandungan Khusus dan Efikasi Kendiri Guru Sekolah Rendah dalam Pengajaran Topik Pecahan* Jurnal Akademika,90(3):145-154.
- Omar, M. S., Saad, N. S., & Dollah, M. U. (2017, April 27). *Penggunaan bahan bantu mengajar guru matematik sekolah rendah*. Jurnal Pendidikan Sains Dan Matematik Malaysia, 7(1), 32–46. <https://doi.org/10.37134/jsspj.vol7.no1.3.2017>
- Pamuda, D., & Mahmud, M. S. (2022, October 31). *Kompetensi Guru dalam Pengajaran Konsep Matematik: Kajian Literatur Bersistematik*. Malaysian Journal of Social Sciences and Humanities (MJSSH), 7(10), e001850. <https://doi.org/10.47405/mjssh.v7i10.1850>
- Poçan, S., Altay, B., & Yaşaroğlu, C. (2022, July 5). The Effects of Mobile Technology on Learning Performance and Motivation in Mathematics Education. Education and Information Technologies, 28(1), 683–712. <https://doi.org/10.1007/s10639-022-11166-6>
- Smart, A., & Jagannathan, S. (Eds.). (2018, December). *Textbook Policies in Asia*: <https://doi.org/10.22617/tcs189651-2>
- Wriston, J. M. (2015). *The Importance of a Strong Mathematical Foundation*.



128-105

ORGANIZATIONAL CULTURE ON EMPLOYEE PERFORMANCE: A CASE STUDY ON CIVIL SERVANTS IN PALEMBANG INDONESIA

1. Inten Meutia
2. Zunaidah
3. Isni Andriana

ABSTRACT

Implementation of appropriate organizational culture, such as clan culture, adhocracy, and market, can significantly influence employee performance in Palembang. Clan culture encourages a collaborative and friendly work environment, increasing employee motivation and dedication. Meanwhile, adhocracy culture fuels creativity and innovation, which is especially important in the construction industry. Focusing on results and competition, in line with market culture, can also improve employee performance. However, the influence of a hierarchical culture must be considered to ensure that the emphasis on supervision and control does not inhibit employee motivation and creativity. Concrete steps such as training, improving compensation systems, and implementing reward and recognition programs are needed to improve employee performance. Although challenges in implementation still exist, identifying and resolving these obstacles is key to achieving optimal performance in various government institutions.

Keywords: Organizational Culture, Employee Performance, Implementation.

INTRODUCTION

Civil Servants (PNS) are the main element in government administration and have a strategic role in determining the success of development in various aspects, especially in developing human resources in the public sector. The performance of each civil servant is a key success factor in achieving human resource development goals which are national priorities (Taufik 2020). However, the performance of each civil servant often does not reach the target due to various phenomena such as policy changes which in this case can affect their work and life. A phenomenon commonly faced by civil servants when policy changes occur is uncertainty regarding the implications of policy changes on employment and working conditions which include changes in duties, employment status, changes in the salary system and benefits. Then there are complex administrative adjustments where civil servants have to change work processes, reporting systems or documents required to comply with new policies. Apart from that, policy changes can also affect the dynamics of the work environment within government agencies. Civil servants may need to adapt to changes in organizational culture, relationships between coworkers, or the level of stress generated by such changes.

Apart from the phenomenon of policy change, bureaucratic reform can also affect the performance of civil servants. When there was bureaucratic reform, civil servants often face various problems that can affect their work and life, such as during bureaucratic reform, changes often occur in organizational structure, duties and responsibilities. This can create uncertainty among civil servants about their roles and responsibilities in the new work



environment. In addition, bureaucratic reform often accompanies changes in work policies and procedures so that you have to relearn or adapt to new policies and procedures. Civil servants are expected to be able to adapt to the changes that occur, because bureaucratic reform can create a need for additional training or professional skills development, in which case if access is not met and there is a lack of support it will become a problem for some civil servants. Then, there is a new performance evaluation in government whose aim is to increase accountability and performance, but this can cause anxiety or uncertainty because civil servants feel pressured to achieve the targets that have been set. Some civil servants also do not respond positively to bureaucratic reform, in which case some of them may show resistance to change, either because they disagree with the direction of reform or because of concerns about the impact on their work and careers. Therefore, it is important for the government to pay attention to these issues and provide adequate support to civil servants during this period of policy change and bureaucratic reform. Effective communication, adequate training, fair rewards and social support can help reduce negative impacts and increase the successful implementation of new policies.

To improve performance, civil servants can use information technology, which has been proven to have a positive and significant impact on employee performance. It is hoped that the implementation of an electronic-based government system that has experienced improvements will have a positive impact on the government's performance in providing services to the wider community. Apriansyah, et al (2024) show that information technology significantly moderates the influence of work systems on employee performance. However, the test results show that the influence of leadership and exchanges between leaders and team members on employee performance is not moderated by information technology with a negative effect. Balanced position arrangements, leadership, work systems, and relationships between leaders and members have a positive and significant influence on the performance of civil servants. Information technology moderates the positive influence of position arrangements and work systems on the performance of civil servants where information technology strengthens the influence of position arrangements and work systems on the performance of these employees. However, information technology does not moderate the influence of leadership and the relationship between leaders and members on employee performance, because the influence of leadership and relationships between leaders and members cannot always be achieved through the use of information technology, but through direct interaction.

In fulfill the mandate of Presidential Regulation Number 29 of 2014 concerning the Government Agency Performance Accountability System (SAKIP). The Palembang City Government in 2022 describes the performance of the Palembang City Government and evaluates the performance targets that have been achieved, as well as the results of evaluation and performance analysis that reflect success and failure. The results of measurements on the 20 (twenty) Main Performance Indicators of the City of Palembang which have been determined in 2022, are as follows(LKjIP Palembang 2022):

1. 16 indicators or 80%, Very High category (achievement $91\% \leq 100\%$)
2. 2 indicators or 10%, High category (achievement $76\% \leq 90\%$);
3. 2 indicators or 10%, Very Low category (achievement $\leq 50\%$).

Then, if we look at employee performance, this is a crucial matter that must be considered by the government to ensure its smooth functioning. Various factors such as organizational commitment, professionalism and career development also have a significant impact on employee performance. However, in practice, there are challenges in improving this



performance in various organizations experiencing a decline in employee performance due to low employee work discipline. This can be seen from the increasing level of employee absenteeism in the last few years, where employees do not notify them if they are sick or have missed the deadline for work permits or leave, arrive late, leave the office without permission, rest later than the specified time, are not in their position and often doing other work outside the employee's expertise and employee work discipline is still less than optimal and policies should be taken to overcome the problem by implementing preventive discipline, corrective discipline and progressive discipline (Ariyanto 2021). To overcome this problem, concrete steps are needed. First, agencies must strengthen the quality of human resources (HR) by providing appropriate training and development. This will help increase employee professionalism and their commitment to the organization. Second, there is a need to improve the employee compensation system to increase job satisfaction. Commitment to career development and clear feedback can also help increase employee job satisfaction. Lastly, implementing reward and recognition programs can be an additional incentive to improve their performance.

LITERATURE REVIEW

Organizational culture is a shared perception shared by all members of the organization (Muis, et al 2018). Covers how people interact with each other, how decisions are made, how teams work, and how to resolve conflict. Organizational culture reflects the identity of an organization and provides direction for how organizational members should act and think. Meanwhile, performance is the result of a person's work which describes the quality and quantity of work that has been done (Astuti 2022). Performance between one person and another may differ, due to different driving factors. Employee performance determines whether the agency's performance is effective or not, which is not only related to achieving targets or results produced, but also includes aspects such as work quality, productivity, initiative, creativity, teamwork, and the ability to adapt to change.

Increased interest in the welfare of civil servants has become a major focus among academics and employers. One of the key ways to improve employee welfare is to apply Cameron's theory, one of which is that clan culture is characterized by a pleasant workplace, like a big family. The characteristics of this type of organization with a "Clan" culture are team work (not individual), employee involvement programs, corporate commitment to employees and development of employees and customers who are considered partners. In clan cultures, commitment is a core value that influences organizational culture. This commitment reflects the level of employee dedication and loyalty to the organization (Watanabe et al. 2023). In this context, high commitment to the organization can motivate employees to make maximum contributions to their work, which in turn can improve their performance. Clan culture emphasizes the importance of effective communication among organizational members. Then, human resource development becomes the main focus. It includes a variety of activities designed to enhance employee skills, knowledge and capabilities.

Apart from clan culture, organizational cultures such as adhocracy, market and hierarchy cultures provide good influence and competition for companies. Adhocratic culture is a type or type of organizational culture that is characterized by a dynamic and entrepreneurial workplace. Leadership that supports an adhocracy culture provides direction and inspiration to dare to take risks, experiment and create innovation (Yang, 2022). An adhocracy culture encourages employee empowerment and assigns greater responsibility to individuals or teams. This can increase employees' intrinsic motivation, because they feel in control and have the opportunity



to make a significant contribution to the success of the organization. Employees who feel valued and have autonomy in their work tend to demonstrate higher performance. Then, market culture also plays a key role in determining the performance and success of a company. In the context of the construction industry, a deep understanding of organizational culture is crucial in facing competitive dynamics and achieving company goals. In a comparative analysis between the current condition of organizational culture and what is expected in the future, this will be the focus of the evaluation (Harun, et al. 2022).

The final dimension is hierarchical culture, namely a government culture characterized by the existence of an official and structured form of agency. Standard procedures serve to regulate employee actions. Hierarchical culture can be related to the influence of organizational culture on employee performance. A hierarchical culture that emphasizes control and supervision in influencing employee performance in terms of efficiency and consistency in carrying out tasks. In an organizational culture that emphasizes hierarchy, employees may feel pressure to comply with established procedures and rules, which can influence the way they work and contribute to achieving governance goals. (Sultan, T 2023).

Organizational culture has a significant influence on employee performance, this is the basis because organizational culture can create a work environment that supports, motivates and empowers employees to achieve optimal performance. With a good organizational culture, employees tend to feel more involved, enthusiastic, and have a high sense of responsibility for their work, thus having a positive impact on their productivity and work quality. Research result (Duggio 2020), organizational culture simultaneously (constructive, passive-defensive and aggressive-defensive culture) has a positive and significant effect on employee performance at the Duingingi Subdistrict Office, Gorontalo City. Partially, constructive, passive-defensive and aggressivedefensive cultures each have a significant influence and the development of a better organizational culture can improve employee performance.

METHOD

The method used in this research is a conceptual descriptive method. This article discusses organizational culture and civil servant performance in Palembang, Indonesia.

DISCUSSION

Phenomena that occur such as policy changes and bureaucratic reform in a government can have a significant impact on organizational culture and employee performance. Changes in organizational structure, work procedures, and assigned tasks can disrupt pre-existing cultural dynamics, giving rise to uncertainty due to policy changes and bureaucratic reforms causing an unstable work environment, which in turn affects how organizational members interact with each other, make decisions, and collaborate. The response to these changes can also reflect the culture of the organization. For example, if there is resistance to change, this may indicate disagreement with the direction of reform or concern about its impact.

Policy changes and bureaucratic reforms can directly affect employee performance. When changes occur in duties, responsibilities, or work procedures, employees may need time to adapt, which can disrupt their productivity. Uncertainty regarding the implications of policy changes can also create high levels of stress among employees, which in turn can negatively



affect their performance. If policy changes or bureaucratic reforms are not supported by adequate infrastructure, such as additional training or professional skills development, employee performance can be negatively affected.

Therefore, there is a link between the phenomenon of policy change and bureaucratic reform and organizational culture or employee performance. A good organizational culture can help overcome the challenges that arise as a result of policy change and bureaucratic reform. For example, a culture that supports innovation and adaptability can facilitate the process of adapting to environmental changes. If organizational culture places a priority on effective communication, teamwork, and social support, employees are likely to be better able to face the challenges of policy change and bureaucratic reform. In this case, it is important for organizational leaders to pay attention to the impact of policy changes and bureaucratic reform on organizational culture and employee performance. Measures such as effective communication, adequate training, and providing social support can help reduce negative impacts and increase employee adaptation to change. Additionally, strengthening an adaptive and supportive organizational culture and ensuring adequate infrastructure to support change can be important strategies in facing these challenges.

Regarding employee performance in the Palembang City Government, this can be done by linking the concept of organizational culture that has been mentioned. The implementation of clan culture can encourage the formation of a collaborative and friendly work environment, this is also one way of improving the performance of civil servants in Palembang. High levels of organizational commitment can also trigger greater dedication to work, potentially improving overall performance. Adhocratic culture can trigger creativity and innovation among employees in Palembang. In a dynamic environment oriented towards controlled risk-taking, employees are encouraged to create new solutions and face challenges in innovative ways. This can improve employee performance because they feel appreciated for the new ideas they convey.

Especially in the context of the construction industry in the Palembang City Government, it can provide additional encouragement for employee performance. With a focus on results and competition, employees are expected to give their best in their work. Regular evaluation of performance and focus on achieving goals can encourage employees to continuously increase their productivity. While a hierarchical culture can ensure structure and discipline within an organization, too much emphasis on supervision and control can negatively impact employee motivation. In Palembang, where there may be a tendency to adhere to established procedures and rules, it is important for management to ensure that employees feel valued and have room to innovate within established limits. By considering these four types of organizational culture, it can be argued that the appropriate implementation of clan, adhocracy, and market culture can improve employee performance in Palembang, while management needs to pay attention to how hierarchical culture can influence employee motivation and creativity.



Table 1 Achievements of Palembang City Government Performance Indicators in 2022

Strategic target		Performance Indicators	Unit	Achievements in 2022		
				Target	Realization	%
1	Equal distribution of infrastructure needs to support regional development	Percentage of congestion points	%	32.26	29.03	110.01
2	Implementation of urban environmental management in a sustainable and sustainable manner	Percentage reduction in Greenhouse Gas (GHG) Emissions	%	8	8	100.00
		Percentage Reduction of Waterlogging	%	68.18	84.85	124.45
3	Availability of decent and environmentally friendly settlements and residential areas	Percentage of Management of Household Waste and Similar Types of Household Waste	%	99	95.8	96.77
		Extent of Slum Settlements in Urban Areas	%	2.4	2.32	103.33
4	Increasing the quality of Human Resources	Human Development Index	%	79.08	79.47	100.40
		Population growth rate	%	1.27	2.58	-3.15
5	Increasing the competitiveness of the workforce and society	Percentage of open unemployment rate	%	7.94	8.2	96.73
6	The development of religious and cultural life values that protect all elements of society	Percentage of the number of morning prayer worshipers in mosques and prayer rooms	%	57.8	52.60	91.00
7	Implementation of good governance practices and competitive government governance	BPK Opinion on the Palembang City Government Financial Report	Opinion	WTP	WTP	100.00



		Results of the Palembang City Government Agency Performance Accountability (AKIP) evaluation results	Category	A	B	85.68
8	Increased regional investment	Number of national scale investments (PMDN/PMA)	IDR Trillion	3.11	4,581	147.29
		National scale investment growth (PMDN/PMA)	%	7	63.34	904.86
9	Even the Distribution of Development Results	Economist growth rate	%	4.5	5.25	116.67
		Gini index (scale 0 – 1)	Index	0.375	0.347	107.47
		Inflation rate	%	2.7-3.2	5.95	14.06
10	The development of a regional economy based on innovation and creative power driven by the community (community centered)	Percentage of poor people	%	10.35	10.48	98.74
		Percentage of micro and small businesses	%	85.37	100	117.14
11	Increasing the competitiveness of the tourism, youth and sports sectors	Number of tourist visits	Person	2,000,000	1,542,485	77.12
		Number of sporting events at local, regional, national and international levels	Events	15	33	220.00

Source: Palembang City Government Agency Performance Report (LKJIP) 2022

Driving Factors for Performance Achievement Factors Driving the successful achievement of this target indicator are:

1. Policy and budget support from city, provincial and central governments,
2. Economic conditions are gradually recovering after the pandemic,
3. The strategic position of Palembang City as the provincial capital,
4. Availability of adequate supporting facilities and infrastructure,
5. High public interest in celebrating sporting events.



CONCLUSION

A good organizational culture can help overcome challenges that arise due to policy changes and bureaucratic reform. A culture that supports innovation, adaptability, effective communication and teamwork can facilitate the process of adapting to environmental changes. In addition, the involvement of organizational leaders in ensuring effective communication, adequate training, and social support can also help reduce negative impacts and increase employee adaptation to change. In the context of employee performance in the Palembang City Government, the implementation of clan culture, adhocracy, market and hierarchy can help improve employee performance. Clan culture can encourage a collaborative work environment, while adhocracy culture can stimulate creativity and innovation. Market culture can also help set a focus on results and competition. Then, a strong hierarchical culture can control, supervise and comply with established procedures or rules, that a good organizational culture has a significant influence on employee performance, and strengthening an adaptive organizational culture can support better employee performance so that it can become a strategy. important in facing the challenges of policy change and bureaucratic reform.

REFERENCES

- Ariyanto, Suryadi. 2021. "The Role Of Work Discipline In Improving The Performance Of Employees In The Field Of Destination Development And Tourism Institutions At The Culture and Tourism Office Of Central Kalimantan Province." *Journal of Social Tourism* 2(1): 15–28.
- Astuti, Goddess. 2022. "The Influence of Organizational Commitment and Organizational Culture on Employee Performance." *Journal of Business Accounting and Management* 2(2): 55–68.
- Dunggio, Swastiani. 2020. "The Influence of Organizational Culture on Employee Performance at the Duingi Subdistrict Office, Gorontalo City." *Public: Journal of Human Resource Management, Administration and Public Services* 7(1): 1–9.
- Muis, et al. 2018. "The Influence of Organizational Culture and Organizational Commitment on Employee Performance." *Jesya (Journal of Sharia Economics & Economics)* 1(1): 9–25.
- Palembang City Government. 2022. "2022 Palembang City Government Agency Performance Report." 6(2): 1–95. <https://organisation.palembang.go.id/userfiles/files/202303291223531kjip-kota-palembang-2022.pdf>
- Taufik. 2020. *Bureaucratic Reform: Learning From Human Resources Reform Efforts In Indonesia* 1 Bureaucratic Reform: Learning From Human Resources Reform Efforts In Indonesia.
- Watanabe, Y. et al. 2023. "Person-Organization Fit in Japan: A Longitudinal Study of the Effects of Clan Culture and Interdependence on Employee Well-Being." *Current Psychology*.
- Yang, L. 2022. "Exploring the Relationship Among Transformational Leadership, Employees' Commitment To an Organization, Clan Culture and Adhocratic Culture Within Taiwan'S Nurturing Foundation for the Disabled Within Taiwan." *IJOI The International Journal of Organizational Innovation* 15(2): 2022–1264. <https://www.ijoi-online.org/>



129-106

**KESESUAIAN TEORI KEPIMPINAN DISTRIBUTIF DENGAN
KOMITMEN DAN KEPUASAN KERJA DALAM MENANGANI ISU
SUMBER DI ORGANISASI PENDIDIKAN**

Muhammad Mustaqim Azman
Fakulti Pendidikan
Universiti Kebangsaan Malaysia, 43600, Bangi, Selangor, Malaysia
Emel: p130722@siswa.ukm.edu.my, Tel: 018-2756991

Prof. Madya Dr. Bity Salwana Alias
Pusat Kajian Kepimpinan & Polisi Pendidikan
Universiti Kebangsaan Malaysia, 43600, Bangi, Selangor, Malaysia Emel:
bity@ukm.edu.my, Tel: 012-3725032

ABSTRAK

Kepuasan kerja dan komitmen guru adalah isu yang tidak pernah berkesudahan. Kajian terdahulu menguji hubungan antara pelbagai amalan kepimpinan dengan kedua-dua isu tersebut. Antara amalan adalah kepimpinan distributif yang bersandarkan kepada teori kepimpinan distributif. Kertas ini bertujuan membincangkan kesesuaian antara elemen-elemen dalam Teori Kepimpinan Distributif dengan elemen-elemen dalam kepuasan kerja dan komitmen. Dapatan kajian terdahulu menunjukkan tahap hubungan yang berbeza. Dapatan ini bagaimanapun tidak menggambarkan tahap kesesuaian tersebut. Perbincangan dalam kertas ini menunjukkan wujud keselarian antara teori kepimpinan distributif dengan kepuasan kerja guru dan wujud keselarian antara teori kepimpinan distributif dengan komitmen kerja guru. Dapat disimpulkan bahawa dalam menjalankan kajian kesesuaian antara pemboleh ubah bersandar dan pemboleh ubah tidak bersandar boleh ditentukan dengan berpandukan kepada elemen-elemen yang terdapat dalam teori yang dirujuk bagi membangunkan instrumen bagi mengukur pemboleh ubah. Justeru untuk kajian yang lebih bermakna pada masa hadapan, cadangan strategi yang lebih tepat dikemukakan untuk menangani isu atau masalah yang dikenal pasti.

Kata Kunci: Kepimpinan, Kepimpinan Distributif, Teori, Isu Sumber, Organisasi Pendidikan.

PENGENALAN

Transformasi ke arah pendidikan yang cemerlang memerlukan kepimpinan berkualiti dan berprestasi tinggi. Keperluan semasa dalam sebuah kepimpinan menuntut pemimpin yang dapat mengurus dan mentadbir bersama-sama dengan semua ahli organisasi. Menurut Syed Abdullah dan Syed Zarizi (2020) PPPM 2013-2025 memfokuskan kepada pembentukan pemimpin sekolah yang mahir dan kompeten bagi merancang serta mengurus segala tugas yang berkaitan dengan sekolah. Thien dan M. Lee (2019) berpendapat untuk membuat perubahan dalam pendidikan pelbagai pihak harus berganding dalam membentuk modal insan yang seimbang dan holistik. Bagi Azizul Asi dan Mohamed Yusof (2018) pula bersetuju dengan saranan PPPM 2013-2025 bahawa sebagai pemimpin sekolah perlu melakukan perubahan



daripada kepimpinan tradisional kepada kepimpinan distributif bagi membentuk kepimpinan yang berkualiti. Oleh sebab itu, amalan kepimpinan distributif diketengahkan dalam pentadbiran pendidikan kerana bertepatan dengan dan selari dengan tuntutan semasa.

ARTIKEL 1: KEPIMPINAN DISTRIBUTIF GURU BESAR DAN KOMITMEN GURU DI SEKOLAH KEBANGSAAN DI DAERAH GOMBAK

TEORI KEPIMPINAN DISTRIBUTIF

DEFINISI

Kepimpinan distributif ialah satu konsep kerjasama serta mengagihkan tugas-tugas kepada orang bawahnya (Ahmad, Sinirah dan A. Hamid, 2021). Bagi seorang pemimpin sekolah kebiasaannya berada pada hierarki tertinggi dalam sesebuah organisasi, pembahagian bidang kuasa kepada budaya sekolah, sanggup berkongsi kepimpinan bersama orang bawahan dianggap sebagai pendekatan berisiko dalam hal akauntabiliti. Bagi Hamzah (2020) kepimpinan distributif merupakan amalan perkongsian tugas kepimpinan bersama ahli organisasinya. Sebagai pemimpin pula hendaklah mengamalkan perkongsian tugas dengan ahlinya bagi mewujudkan kecemerlangan dalam sebuah organisasi selain menjadi pemimpin instruksional (Samancionglu et al., 2020). Hal ini kerana, menurut Jambo, Daniel dan Hongde (2020) amalan gaya kepimpinan distributif mampu membantu guru-guru untuk menjana idea baharu atau membuat inovasi dalam pengurusan sekolah. Vigneswary et al., (2019) pula berpandangan seorang pemimpin bertanggungjawab untuk berkongsi kuasa sesama ahli organisasinya sama ada secara formal atau tidak formal. Proses pengagihan kepimpinan di sekolah boleh difahami sebagai usaha kepada guru besar berkongsi tanggungjawab dengan guru-guru lain, merasai tugas secara individu serta cara guru besar, guru-guru dan murid berkomunikasi antara satu sama lain dalam rangka merealisasikan dan menghayati konsep kepimpinan secara lebih menyeluruh dan membina persekitaran.

PELOPOR TEORI KEPIMPINAN DISTRIBUTIF

James P. Spillane ialah professor Spencer T. dan Ann W. Olin dalam pembelajaran dan perubahan organisasi di Universiti Northwestern. Beliau telah menerbitkan secara meluas berkaitan polisi pendidikan, pelaksanaan polisi, reformasi sekolah dan kepemimpinan sekolah. Beliau juga pernah berkhidmat sebagai guru sekolah rendah di Ireland serta pakar dalam bidang perkembangan manusia dan dasar sosial selain dasar pendidikan kerajaan dan kepimpinan sekolah. Beliau juga telah mengarang buku: "How schools Misunderstood Education Policy" (2004) dan banyak jurnal.

KEPENTINGAN TEORI KEPIMPINAN DISTRIBUTIF

Blasé dan Blasé (2001) menyokong amalan kepimpinan distributif kerana ia mampu menambah kepuasan kerja dalam kalangan guru. Seterusnya ia dapat menambahbaik budaya sekolah serta pengalaman pembelajaran dalam kalangan guru dan murid (Lambert, 2003) dan (Barth, 2001). Bagi Song (2007) pula amalan kepimpinan distributif juga memberi impak serta mempengaruhi aspek pengurusan dan kualiti sekolah serta keberkesanan dalam PdPc. Kajian Hulphia et al. (2009) membuktikan persepsi guru terhadap kepimpinan distributif mempunyai hubungan kait dengan komitmen guru dalam sesebuah organisasi. Hal ini bermakna, guru-guru menunjukkan kepuasan kerja dengan bidang tugas yang diberi menerusi



komitmen yang tinggi hasil pelaksanaan kepemimpinan distributif yang membenarkan mereka membuat keputusan dan turut menjadi pemimpin.

Antara kepentingan lain, amalan distributif mampu membina hubungan antara pemimpin sekolah, guru serta warga sekolah. Hal ini didapati dalam Harrison (2005) apabila kolaborasi antara guru meningkat dan saling menyokong antara satu sama lain. Ini ialah hasil pemimpin sekolah yang komited dalam pengagihan kepemimpinan dalam kalangan guru, mengutamakan budaya kolaboratif, fokus ke arah visi dan hala tuju sekolah dan memastikan amalan kepemimpinan disemai dalam kalangan guru. Dalam Baskaran dan A. Hamid (2020) pula berpendapat bahawa pemimpin sekolah memiliki peranan penting dalam menyumbang prestasi yang cemerlang dalam organisasi dan ia berpunca daripada pemimpin yang berwibawa. Menurut mereka lagi, kepemimpinan distributif ialah kepemimpinan terbaik yang mampu memudahkan pengurusan dan menyemai motivasi dalam kalangan guru demi merealisasikan matlamat sekolah.

DIMENSI TEORI KEPIMPINAN DISTRIBUTIF

Teori kepemimpinan distributif membahagikan kepada empat dimensi yang dibangunkan oleh Connecticut State Department of Education (CSDE). Dimensi satu mengenai penetapan dan perkongsian misi, visi dan matlamat sekolah. Kepimpinan distributif melibatkan semua pihak berkepentingan dalam merumuskan visi, misi dan matlamat sekolah. Ini boleh dilaksanakan melalui sesi perbincangan dan aktiviti kolaboratif bagi mendorong guru dan staf untuk bertukar-tukar idea dan pandangan. Guru berperanan penting dalam membentuk visi, misi dan matlamat sekolah bagi memastikan ia selaras dengan kehendak warga sekolah serta komuniti. Dimensi kedua pula ialah budaya sekolah iaitu kerja dan kolaborasi komuniti pembangunan profesional. Dimensi budaya sekolah merangkumi pemeraksanaan guru dan keberkesanan warga sekolah. Dalam erti kata lain, kepemimpinan distributif melibatkan pengagihan tanggungjawab dan kuasa kepada guru-guru untuk membuat keputusan dan melancarkan proses PdPc.

Budaya kerja yang positif juga mendorong guru untuk meningkatkan pembangunan profesional mereka sekaligus mencipta kecemerlangan dalam diri masing-masing. Elemen kolaborasi komuniti pembangunan profesional pula ialah mendorong budaya yang mewujudkan penglibatan aktif antara ibu bapa dalam pembangunan pendidikan anak-anak mereka di sekolah. Sebagai contoh, ibu bapa menghadiri dialog prestasi untuk mengetahui perkembangan anak-anak mereka dalam pembelajaran. Pertukaran ilmu juga sangat penting bagi menyokong budaya kolaboratif bersama pakar-pakar luar yang arif dalam bidang pendidikan bagi membina hubungan dan saling memperkaya ilmu dalam perkembangan profesional. Dimensi ketiga ialah perkongsian tanggungjawab sebagai pentadbir atau guru perlu saling membantu dalam menangani tugas tertentu berdasarkan kepakaran masing-masing. Selain itu, setiap guru perlu menjadikan pemimpin sebagai pembimbing seperti mengadakan aktiviti mentor-mentee untuk meningkatkan kemahiran khususnya dalam pengajaran.

Dan dimensi keempat pula amalan kepemimpinan melibatkan pengagihan tanggungjawab, kuasa dan membuat keputusan kepada pelbagai individu, kakitangan dan staf dalam organisasi. Dengan itu, pemimpin perlu mengambil kira dan melihat daripada pelbagai sudut seperti membina hubungan sesama warga sekolah, memberi bimbingan dan sokongan serta membuat penilaian dan penghargaan kepada semua guru sebagai warga kerja yang sentiasa menjalankan tugas dengan baik. Oleh itu, semua dimensi teori kepemimpinan distributif ini memainkan peranan yang sangat penting bagi mendedahkan dan membiasakan guru-guru tentang kepemimpinan ini dengan lebih luas dan jelas.



KESESUAIAN DALAM KONTEKS PENDIDIKAN

Dalam Ishak (2009) menyatakan bahawa kepimpinan distributif dibuktikan apabila pemimpin sekolah bersedia untuk membahagikan bidang tugas serta memberi hak kepada guru untuk membuat keputusan. Ini turut disokong oleh Rosnarizah Abdul Halim dan Hussein Ahmad (2015) yang berpandangan bahawa kunci utama yang menjelaskan konsep kepimpinan distributif di sekolah ialah guru perlu mempunyai inisiatif untuk berkongsi tanggungjawab. Hal ini turut dinyatakan dalam MySG KPM di bawah garis panduan tadbir urus sekolah menengah dan rendah iaitu membentuk budaya kebertanggungjawapan kepemimpinan.

Dalam PPPM 2013-2025 anjakan kelima juga menegaskan tentang elemen membangunkan keupayaan kepimpinan staf. Dalam erti kata lain, pemimpin sekolah perlu memastikan kepimpinan berprestasi tinggi disemaikan di sekolah dengan melihat kepada pelbagai sudut seperti pengurusan sekolah, jalinan dan jaringan warga sekolah serta kemenjadian murid dan guru. Kajian Ahmad dan Hamid, (2021) menyatakan bahawa tahap amalan kepimpinan distributif dalam kalangan guru prasekolah berada pada nilai min tinggi. Ini menunjukkan bahawa guru-guru di sekolah bersedia menerima amalan kepimpinan distributif yang dilaksanakan oleh guru besar. Jamalullail et al. (2013) turut membuktikan dalam kajiannya bahawa pengaruh kepimpinan distributif dalam sistem pendidikan negara semakin meluas dan selari dengan gelombang 2 bab 5 PPPM 2013-2025 yang mana menekankan amalan kepimpinan distributif merupakan usaha melestarikan sistem pendidikan negara dan menunjukkan kecemerlangan di peringkat sekolah. Melalui kepimpinan distributif juga, ia sangat sesuai diterapkan dalam konteks pendidikan negara yang mana ia memupuk bakat yang ada pada guru atau staf. Hal ini turut dinyatakan dalam elemen kemenjadian guru dan sekolah berkualiti atau disebut sebagai konsep TS25.

TEORI KOMITMEN GURU

DEFINISI

Teori komitmen Meyer dan Allen (1984) menjelaskan komitmen ialah suatu konstruk psikologi guru terhadap organisasi untuk meneruskan profesion dalam organisasi yang sama. Dalam kajian Subramaniam A. (2022) menyatakan komitmen guru ialah seseorang ahli mempunyai keinginan kuat untuk tetap sebagai anggota, keinginan untuk bekerja keras sesuai dengan kehendak organisasi tersebut, serta menerima nilai dan tujuan organisasi. Ini turut ditambah dalam Fatimah Affendi (2014) bahawa pekerja yang dapat memberikan komitmen kepada organisasi mampu bertahan di dalam organisasi berbanding pekerja yang tidak mempunyai komitmen terhadap organisasi. Komitmen organisasi terbahagi kepada tiga komponen iaitu afektif, berterusan dan normatif. Ketiga-tiga dimensi ini mempunyai hubungkait dengan komitmen guru iaitu guru yang mempunyai komitmen tinggi tidak meninggalkan organisasi dalam apa jua keadaan. Hal ini dipersetujui dalam Yakub (2017) bahawa hubungan antara pemimpin sangat penting bersama ahlinya dengan tujuan membina komitmen yang tinggi terhadap organisasi.

PELOPOR TEORI KOMITMEN KERJA

Antara pelopor teori komitmen guru ialah John P. Meyer yang terlibat dalam perkembangan model komitmen sesebuah organisasi. Beliau merupakan Profesor Psikologi Industri dan Organisasi di Universiti Akron, Ohio Amerika Syarikat. Beliau juga banyak meneliti dalam komitmen organisasi, kepuasan kerja dan perubahan sesebuah organisasi. Manakala Natalie J.



Allen pula merupakan Profesor Psikologi Industri dan organisasi di Universiti Western Ontario Kanada. Allen turut memberi tumpuan dalam bidang psikologi organisasi dan memperluas kajiannya dalam interaksi antara individu dan organisasi.

KEPENTINGAN TEORI KOMITMEN KERJA

Teori komitmen guru merujuk kepada konsep bahawa tahap penglibatan dan komitmen seorang guru terhadap sekolah dan kerjaya mampu memberi kesan kepada kualiti pendidikan terhadap guru, murid dan warga sekolah. Kepentingan teori komitmen guru terdiri daripada pelbagai aspek yang mempengaruhi pengurusan dan persekitaran sekolah. Antaranya ialah kualiti pengajaran iaitu guru yang memiliki tahap komitmen yang tinggi akan cenderung untuk lebih berdedikasi dengan melibatkan diri dalam perkembangan kurikulum, mencipta inovasi dalam kaedah pengajaran dan terus meningkatkan ketrampilan mereka.

Selain itu, komitmen guru juga mempengaruhi kesejahteraan murid. Guru yang prihatin dan komited terhadap pendidikan murid mampu menghasilkan suasana pembelajaran yang positif, memberi sokongan emosi dan mengambil berat terhadap keperluan murid-murid. Antara lain kepentingan teori komitmen guru ialah prestasi sekolah. Apabila guru komited dengan tanggungjawab yang diberi serta bekerjasama dalam sebuah organisasi, menyumbang idea dan bekerja untuk mencapai tujuan yang sama mampu meningkatkan kualiti pendidikan secara menyeluruh. Hal ini secara tidak langsung mampu meningkatkan kepimpinan sekolah. Guru yang menunjukkan komitmen kerja yang tinggi akan sentiasa menjadi agen perubahan dan menyokong kepimpinan sekolah yang efektif. Mereka akan menjadi tauladan kepada rakanrakan guru lain dan sentiasa menyumbang sesuatu terhadap budaya sekolah yang dinamik.

DIMENSI TEORI KOMITMEN KERJA

Kelloway, Catano dan Southwell (1992) mengemukakan tiga dimensi komitmen organisasi iaitu kesetiaan terhadap organisasi, tanggungjawab terhadap organisasi dan kerelaan bekerja untuk organisasi. Sverke dan Kuruvilla (1995) pula mencadangkan dua dimensi komitmen kerja iaitu nilai/ideologi dan alat bantuan. Menurut mereka, kedua-dua dimensi ini mempunyai perhubungan dengan niat tingkah laku kesatuan dan seterusnya kepada penyertaan organisasi. Mengikut Gordon et al. (1980) komitmen organisasi mempunyai empat dimensi iaitu kesetiaan terhadap organisasi yang merujuk kepada rasa bangga dalam pergaulan dengan organisasi dan ahli-ahli serta persepsi organisasi yang memenuhi keperluan ahli. Kedua, tanggungjawab terhadap organisasi iaitu tahap tanggungjawab untuk memenuhi kewajipan harian serta tugas ahli supaya dapat melindungi kepentingan organisasi. Ketiga pula, kerelaan bekerja untuk organisasi iaitu kesediaan ahli-ahli bekerja lebih untuk organisasi dan keempat ialah kepercayaan terhadap organisasi iaitu kepercayaan umum terhadap konsep organisasi.

Friedman dan Harvey (1986) menyatakan terdapat dua faktor komitmen organisasi yang lebih umum terhadap sikap dan tingkah laku iaitu sikap kesatuan dan pendapat yang merujuk kepada pendapat, kesan dan sikap yang dipegang oleh ahli terhadap organisasi dan niat tingkah laku. Menurut Meyer dan Allen (1984) pula terdapat tiga dimensi dalam komitmen organisasi iaitu afektif, terus bekerja untuk organisasi, berterusan, terus bekerja untuk organisasi kerana tiada usaha melakukan perkara lain dan normatif iaitu terus bekerja untuk organisasi kerana berhadapan dengan tekanan daripada orang lain.

KERANGKA KONSEPTUAL

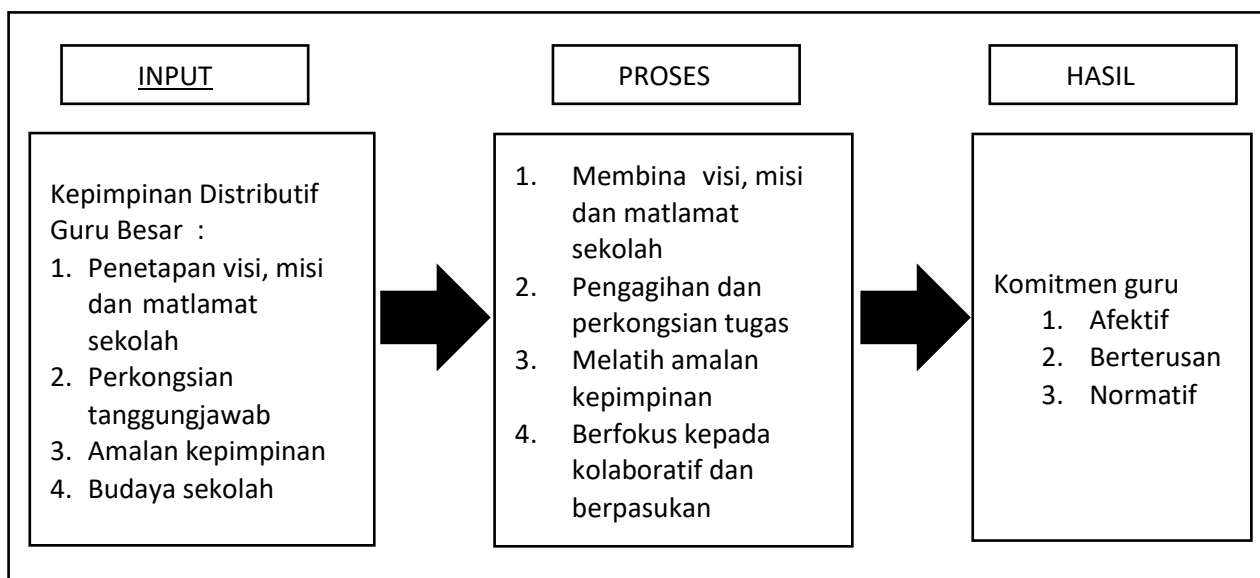

Bahagian ini membincangkan mengenai kerangka konseptual kajian. Kerangka konsep dibentuk untuk mengenalpasti komponen untuk setiap pemboleh ubah. Kerangka konsep ini terbahagi kepada tiga peringkat iaitu input, proses dan hasil. Seterusnya aspek di dalam kerangka bagi input iaitu penetapan visi, misi dan matlamat organisasi, perkongsian tanggungjawab, amalan kepimpinan dan budaya sekolah.

KESESUAIAN DALAM KONTEKS PENDIDIKAN DI MALAYSIA

Faktor komitmen kerja terhadap sesebuah organisasi merupakan isu yang paling mencabar dan menjadi tumpuan dalam bidang pengurusan. Dalam Ma'rufi dan Anam (2019) juga bersetuju bahawa tanpa sokongan guru, sesebuah sekolah itu tidak akan berjaya kerana komitmen guru sangat mempengaruhi pencapaian sebuah sekolah. Dapatan kajian K. Ramathevi dan Razak A. Z. A (2021) pula menunjukkan bahawa guru besar telah menyediakan suasana yang memberi galakan dalam penglibatan guru. Hal ini berlaku apabila kepimpinan distributif yang dilaksanakan oleh guru besar mengutamakan komitmen kerja. Kenyataan ini dipersetujui dalam Ismail et al., (2022) bahawa komitmen dapat diterjemahkan melalui reaksi guru terhadap kerjayanya serta mempamerkan dedikasi dan kesetiaan mereka terhadap tempat mereka bekerja. Antara lain, guru perlu hadir dan patuh kepada peraturan, melibatkan diri secara aktif dalam kegiatan sekolah, memberi fokus terhadap kualiti pengajaran dan cenderung untuk menyumbang idea, tenaga serta wang ringgit demi perkembangan holistik murid. Justeru Thien, Lei M. dan Tan M. Y (2019) dalam kajiannya, kepimpinan distributif guru besar mempunyai perkaitan dalam meningkatkan komitmen dalam kalangan guru di sekolah.

ARTIKEL 2: AMALAN KEPIMPINAN DISTRIBUTIF DALAM KALANGAN PENGETUA SERTA HUBUNGANNYA DENGAN KEPUASAN KERJA GURU DI SELANGOR

TEORI KEPUASAN KERJA GURU

DEFINISI



Musfi Efrizal (2011) melihat kepuasan kerja sebagai keadaan emosi pekerja terhadap balasan yang diterima hasil daripada titik peluh yang dicurahkan kepada pekerjaan tersebut. Salah satu perkara yang dapat meningkatkan kepuasan kerja guru ialah pelaksanaan penilaian prestasi yang terurus dan bersesuaian dengan kerja guru (Perillo, 2006). Wexley dan Yukl (1984), mendefinisikan kepuasan kerja sebagai cara seseorang pekerja merasa tentang tugasnya. Robbins (2003) membuat takrifan kepuasan kerja sebagai suatu sikap umum individu terhadap pekerjaannya. McShane dan Glinow (2003) pula mendefinisikan kepuasan kerja sebagai penilaian seseorang tentang pekerjaannya. Dengan ini, kepuasan kerja merupakan cara seseorang merasakan sesuatu atau bersikap positif terhadap kerjanya. Jika seseorang pekerja tidak mendapat kepuasan kerja yang diinginkan, maka mereka akan bertindak negatif kepada organisasi dan tidak menunjukkan sifat komited serratus peratus terhadap tugas yang dipertanggungjawabkan (Zulkafli & Mahbob, 2020).

KERANGKA KONSEPTUAL

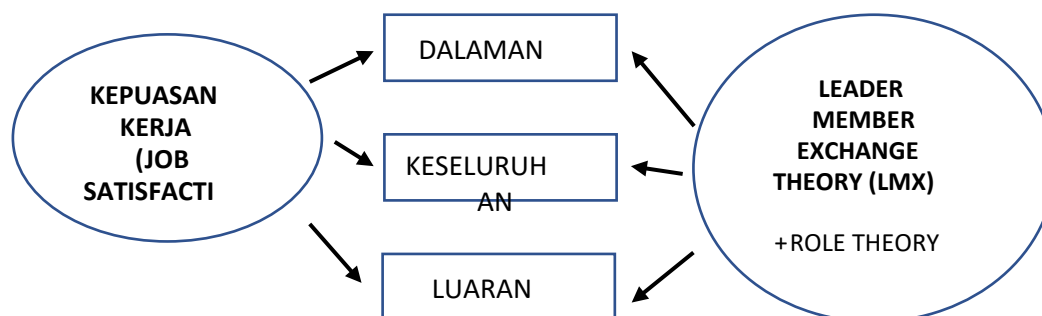

PELOPOR TEORI KEPUASAN KERJA GURU

Antara pelopor teori kepuasan kerja ialah Edwin A. Locke iaitu seorang psikologi dan professor di Universiti Maryland. Pada tahun 1969 beliau bersama Gary P. Latham, Locke mengembangkan teori pengaturan tujuan (Goal Setting Theory) yang akhirnya menjadi asas kepada banyak kajian tentang motivasi dan kepuasan kerja. Teori Locke tentang kepuasan kerja menekankan peranan kefahaman dan pencapaian tujuan seseorang individu dalam mencipta kepuasan di tempat kerja.

Seterusnya, Frederick Herzberg juga terkenal dengan mengembangkan teori motivasi dan faktor kelebihan (Motivation – Hygiene Theory atau Two Factor Theory) yang menerangkan dua set faktor yang mempengaruhi kepuasan kerja dan ketidakpuasan. Faktor kelebihan (hygiene factors) seperti keadaan kerja, gaji dan hubungan antara staf. Manakala faktor motivasi seperti prestasi, tanggungjawab dan pengakuan terhadap menyumbang sesuatu terhadap kepuasan kerja.

Bagi Abraham Maslow pula ialah seorang ahli psikologi serta terkenal dengan Hierarki Keperluan Maslow. Walaupun ia tidak secara khusus fokus kepada kepuasan kerja, konsep Maslow tentang keperluan manusia untuk mendapatkan kepuasan dalam bekerja. Oleh itu, penting untuk difahami dan diketahui tentang pelopor-pelopor yang meneliti dan memperincikan teori kepuasan kerja dengan lebih holistik dan menyeluruh.



KEPENTINGAN TEORI KEPUASAN KERJA GURU

Teori kepuasan guru memberi fokus terhadap tahap kepuasan guru dalam kerjaya, persekitaran kerja dan faktor-faktor lain yang memberi impak kepada kerja dan kualiti pendidikan. Antara kepentingan yang dapat dilihat ialah motivasi dan prestasi. Guru yang berasa puas terhadap kerjayanya mereka cenderung untuk lebih bermotivasi mengajar dan komited terhadap bidangbidang tugas yang diamanahkan. Kepuasan kerja dapat menjadi sumber motivasi dalaman yang mampu meningkatkan kerja secara keseluruhan.

Seterusnya, tahap kepuasan kerja dapat mempengaruhi penempatan guru yang kekal di sekolah yang sama. Guru yang berasa puas dalam persekitaran kerja, mereka lebih cenderung untuk kekal di sekolah tersebut, mengurangkan pemindahan guru dan memberi kestabilan dalam pengurusan sekolah. Kualiti pengajaran juga antara faktor kepuasan kerja demi meningkatkan perkembangan kurikulum dan kemenjadian murid di sekolah.

DIMENSI TEORI KEPUASAN KERJA GURU

Dimensi bagi teori kepuasan kerja sangat penting dalam kalangan organisasi awam, swasta dan organisasi yang tidak bermotifkan keuntungan. Antara sub dalam bahagian ini terdiri daripada bayaran gaji, kenaikan pangkat, penyeliaan, faedah bukan berbentuk kewangan, penghargaan yang tidak dijangka, operasi dan prosedur kerja, persekitaran kerja, rakan sejawat dan komunikasi (Zoolaiha A. Rahman. 2015)

KESESUAIAN DALAM KONTEKS PENDIDIKAN DI MALAYSIA

Pendidikan dapat dilihat sebagai tiang pembangunan di Malaysia dan kepuasan kerja guru memainkan peranan penting dalam mencapai Falsafah Pendidikan Kebangsaan (FPK) demi melahirkan individu yang holistik. Teori kepuasan kerja juga membantu dan menyokong transformasi pendidikan di Malaysia dengan memahami dan menangani keperluan guru. Sebagai contoh, KPM telah memberi tumpuan terhadap kebajikan guru seperti menyuntik semangat guru-guru melalui program laluan kerjaya seperti kenaikan pangkat lebih cepat kepada guru cemerlang. Seterusnya, teori kepuasan kerja mengambil kira kepelbagaian budaya dan bahasa di Malaysia untuk memahami faktor-faktor yang mempengaruhi kepuasan kerja guru daripada pelbagai latar belakang. Dalam erti kata lain, terdapat perbezaan antara peringkat pendidikan seperti sekolah rendah dan menengah, berhadapan dengan jumlah murid yang besar atau kurang murid dan mengambil kira terhadap aras pemikiran murid.

Antara lain, teori kepuasan kerja berkait rapat dengan kesejahteraan guru termasuk aspek kesihatan mental dan emosi yang semakin penting dalam konteks pendidikan Malaysia. Kepuasan kerja menjadikan guru rasa dihargai sekaligus meningkatkan kesejahteraan mereka khususnya di sekolah. Di zaman era digital ini juga, teori kepuasan kerja mengambil kira pengaruh dan perubahan teknologi terhadap tugas dan persekitaran kerja guru. Dalam meneliti kepuasan kerja guru di Malaysia adalah penting untuk mengkaji teori-teori yang mengambil kira konteks budaya, sosial dan ekonomi tempatan. Kesesuaian teori kepuasan kerja di Malaysia memberikan pandangan yang jelas dan relevan demi meningkatkan kualiti pendidikan dan menyokong perkembangan profesional guru.



RUMUSAN

Bagi mencapai aspirasi pihak KPM melalui pelan pendidikan yang terperinci, seharusnya amalan kepimpinan distributif ini dijadikan satu 'blueprint' yang kukuh untuk diamalkan secara meluas di sekolah-sekolah. Hal ini sekaligus menjadikan PPPM 2013-2025 lebih efisien melalui anjakan kelima iaitu memastikan kepimpinan berprestasi tinggi ditempatkan di setiap sekolah. Gelombang kedua ini pula jelas termaktub dalam PPPM 2013-2025 dengan memartabatkan profesion keguruan dan menganjak ke arah kepimpinan teragih (kepimpinan distributif). Kepimpinan distributif ini wajar diberikan ruang secukupnya kepada pemimpin sekolah dan guru untuk memimpin sekolah bersama kepimpinan pengurusan sekolah bagi menjayakan visi dan misi sekolah selari dengan visi KPM.

IMPLIKASI

DASAR

Hasil bacaan yang teliti tentang teori kepimpinan distributif, teori komitmen guru dan teori kepuasan kerja guru dapat disimpulkan bahawa ketiga-tiga teori ini membawa implikasi yang penting untuk meningkatkan pengalaman guru dan prestasi mereka. Pertama, pendekatan kepimpinan distributif dapat meningkatkan kepuasan kerja guru dengan memberikan mereka tanggungjawab, kepercayaan dan peluang untuk terlibat dan membuat keputusan. Sebagai pemimpin pula perlu mengamalkan pengagihan tanggungjawab yang berdaya maju, memberi peluang kepada guru untuk berkongsi idea dan melibatkan mereka dalam membuat keputusan berkaitan pengajaran dan pengurusan sekolah.

LATIHAN

Implikasi kedua pula, guru yang puas dengan pekerjaan mereka lebih cenderung mempunyai komitmen yang tinggi terhadap profesion mereka dan sekolah. Justeru, pemimpin perlu memahami faktor-faktor yang menyumbang kepada kepuasan kerja guru termasuk keperluan perkembangan profesional, persekitaran kerja yang kondusif dan sokongan yang mencukupi. Ini akan membantu meningkatkan komitmen guru terhadap profesion dan institusi mereka.

AMALAN

Implikasi ketiga ialah guru yang puas dan komited terhadap kerja lebih cenderung memberikan pengajaran yang berkualiti sekaligus meningkatkan prestasi muridnya. Oleh sebab itu, pemimpin sekolah perlu memastikan bahawa kepuasan dan komitmen guru diutamakan dengan menyediakan peluang untuk pembangunan profesional, memberi sokongan emosi dan memastikan keseimbangan beban kerja. Seterusnya, kepimpinan distributif dapat membantu mencapai keselarasan antara visi dan misi sekolah dengan melibatkan guru dalam proses membuat keputusan dan menyusun matlamat bersama. Oleh yang demikian, pemimpin perlu memastikan visi dan misi sekolah tidak hanya diumumkan tetapi dihayati oleh warga sekolah. Ini melibatkan penyertaan aktif guru, murid dan komuniti dalam memahami dan melaksanakan tujuan sekolah. Berdasarkan implikasi-implikasi tersebut, ia menunjukkan bahawa pemimpin sekolah yang memahami hubungan antara kepimpinan distributif, kepuasan kerja dan komitmen guru dapat membentuk persekitaran yang kondusif, memberi sokongan dan bimbingan serta meningkatkan prestasi keseluruhan sekolah.



CADANGAN UNTUK KAJIAN AKAN DATANG

Berikut merupakan beberapa cadangan untuk kajian akan datang yang dapat dilakukan dalam konteks kepimpinan distributif, kepuasan kerja guru dan komitmen guru di Malaysia atau dalam konteks pendidikan secara global. Pertama pengkaji boleh menganalisis perbandingan kepuasan kerja guru antara sekolah awam dan swasta serta melihat kepada faktor yang mempengaruhi kepuasan kerja di kedua-dua jenis sekolah di samping meneliti impak kepimpinan distributif dalam merangsang kepuasan kerja dalam konteks sekolah berbeza. Cadangan kedua ialah pengkaji akan datang boleh menganalisis pengaruh faktor budaya dan sosioekonomi terhadap komitmen guru di pelbagai jenis sekolah seperti bandar, luar bandar dan pedalaman.

Cadangan ketiga, pengkaji boleh menggunakan kaedah kajian kes untuk memahami cara sesebuah sekolah melaksanakan strategi kepimpinan distributif, impak terhadap kepuasan kerja dan kepuasan guru di sekolah tersebut. Seterusnya, pengkaji boleh mengkaji keberkesanan polisi pendidikan kebangsaan yang mendorong pelaksanaan kepimpinan distributif di peringkat sekolah serta menilai pelaksanaan tersebut memberi impak positif kepada kepuasan kerja dan komitmen guru. Berdasarkan semua cadangan kajian, dapatlah memberi pandangan yang lebih mendalam dan relevan mengenai keberkesanan kepimpinan distributif, kepuasan kerja dan komitmen guru dalam konteks pendidikan Malaysia. Kajian-kajian ini juga dapat memberikan sumbangan penting kepada pembangunan dan penambahbaikan dalam bidang pendidikan di negara.

RUJUKAN

- Affendi, Fatimah (2014) Tahap Kepuasan Kerja Dan Komitmen Organisasi Dalam Kalangan Guru Kolej Vokasional: pendekatan structural equation model. Masters thesis, Universiti Tun Hussein Onn Malaysia.
- Ahmad, Sinirah, & Aida Hanim A. Hamid. (2021). Amalan kepimpinan distributif guru besar terhadap efikasi sendiri dalam kalangan guru prasekolah Abstrak. *6*(1):140–50.
- Azizul Asi, & Mohd Nor Mohamed Yusoff. (2018). Amalan kepimpinan distributif guru besar dan hubungannya dengan komitmen organisasi guru. *Seminar Pendidikan Transdisiplin*, 247–56.
- Baskaran, K. & A. Hamid, A. H. (2020). Amalan Kepimpinan Instruksional Pengetua Di Sekolah Menengah di Bandar Banting. *International Journal of Education and Pedagogy*, 2(1), 264–284.
- Blasé, J., & Blasé, J. (2001). *Empowering teachers: What successful principals do* (2nd ed.). Thousand Oaks, CA: Corwin Press.
- Ramathevi Kuppan & Ahmad Zabidi Abdul Razak. 2021. Kepimpinan Distributif Guru Besar dan Komitmen Guru di Sekolah Kebangsaan di Daerah Gombak. *Jurnal Kepimpinan Pendidikan*. Hlm 20-35
- Friedman, L. & Harvey, R.J. 1986. Factors of union commitment: The case for a lower dimensionality. *Journal of Applied Psychology* 71(3): 371-376.
- Elmore, R.F. (2000). *Building a new structure for school leadership*. Washington D.C.: The Albert Shanker Institute
- Gordon, M.E., Philpot, J.W., Burt, R.E., Thompson, C.A. & Spiller, W.E. 1980. Commitment to the union: Development of a measure and an examination of its correlates. *Journal of Applied Psychology*, 65(4), 479-499.



- Harris, A. (2002). Building the capacity for school improvement. Paper presented at the American Research Association Conference, New Orleans
- Harris, A., & Muijs, D. (2005). Improving schools through teacher leadership. New York: Open University Press.
- Harrison, N. (2005). The impact of distributed leadership on teachers. (Doctoral dissertation, Indiana University).
- Hopkins, D., & Jackson, D. (2002). Building the capacity for leading and learning dalam A. Harris, C. Day, M. Hadfield, D Hopkins, A, A. Hangreaves and C. Chapman (eds.) Effective Leadership for School Improvement, London: Routledge 84-105
- Hulphia, H., Devos, G., & Rosseel, Y. (2009). The relationship between the perception of distributed leadership in secondary schools and teachers' and teacher leaders' job satisfaction and organizational commitment. *School Effectiveness and School Improvement*, 20(3), 291-317. doi: 10.1080/092434509029098
- Ismail, N. H., Yusof, M. R., Ibrahim, M. Y., Fauzee, M. S. O., & Ismail, R. (2022). Validating suburban teachers' commitments: Let's appreciate their blood, sweat, and tears. *International Journal of Instruction*, 15(3), 103-116.
- Jambo, Daniel, & Lei Hongde. (2020). The effect of principal's distributed leadership practice on students' academic achievement: A systematic review of the literature. *International Journal of Higher Education*, 9(1):189–98. doi: 10.5430/ijhe.v9n1p189.
- Jamalullail Abdul Wahab, Aida Hanim A. Hamid, Surayati Zainal & Md Fuad Md Rafik (2013). The relationship between headteachers' distributed leadership and teachers' motivation in national primary schools. *Asian Social Science*, 9(16), 161-167
- Kelloway, E.K., Catano, V.M. & Southwell, R.R. 1992. The construct validity of union commitment: Development and dimensionality of a shorter scale. *Journal of Occupational and Organizational Psychology* 65(3): 197-211.
- Kementerian Pendidikan Malaysia. (2016). *Pelan Pembangunan Pendidikan Malaysia (PPPM2013-2025)*. Kuala Lumpur: Bahagian Perancangan dan Penyelidikan Dasar Pendidikan, Kementerian Pendidikan Malaysia
- Lambert, L.(2003). Leadership capacity for lasting school improvement (1st ed.). Alexandria, VA: Association for Supervision and Curriculum Development.
- Ma'rufi, Azis Rahmat, & Choirul Anam. (2019). Faktor yang mempengaruhi komitmen organisasi. *Prosiding Seminar Nasional Magister Psikologi Universitas Ahmad Dahlan* (page 442–446). <http://seminar.uad.ac.id/index.php/snmpuad/article/view/3458/788>
- McShane, S.L. and Von Glinow, M.A. (2003) *Organizational Behaviour*. International Edition, McGraw-Hill Education, New York.
- Musfi Efrizal. (2011). Hubungan kepuasan kerja terhadap prestasi kerja karyawan pada rumah sakit islam malang. Perpustakaan UIN Malang. <http://lib.uinmalang.ac.id/?mod=thetailid=05410007>
- Rahman, Z.A. (2015). Amalan Kepimpinan Distributif Dalam Kalangan Pengetua Dan Hubungannya Dengan Kepuasan Kerja Guru Di Selangor.
- Robbins, S.P. and Judge, T. (2003) *Essentials of Organizational Behavior* (Vol. 7). Prentice Hall, Upper Saddle River.
- Ramathevi, K. & Ahmad, Z. (2021). Kepimpinan distributif guru besar dan komitmen guru di sekolah kebangsaan di daerah gombak. *Jurnal Kepimpinan Pendidikan*, 8(4), 20-35. <https://jupidi.um.edu.my/index.php/JUPIDI/article/view/33100>
- Samancioglu, M., Baglibel, M., & Erwin, B. J. (2020). Effects of Distributed Leadership on Teachers' Job Satisfaction, Organizational Commitment and Organizational Citizenship. *Pedagogical Research*, 5(2), em0052. <https://doi.org/10.29333/pr/6439>
- Song, Hongyin. (2007). Literature review of teacher job satisfaction. *Chinese education and Society*, 40(5), 11-16. doi: 10-2753/CED 1061-1932400502
- Subramaniam, A. (2022).



- The Relationship between Job Satisfaction and Commitment among National School Teachers in South Kinta District, Perak. *Management Research Journal*, 11(2), 1-13. <https://doi.org/10.37134/mrj.vol11.2.1.2022>
- Syed Abdullah, Syed Syahrul Zarizi. (2020). The influence of distributed leadership on Professional Learning Community among secondary school leaders in the state of Johore/ Pengaruh kepemimpinan distributif terhadap Komuniti Pembelajaran Profesional dalam kalangan pemimpin sekolah menengah di Negeri.” *Sains Humanika*, 12(2):15– 25. doi: 10.11113/sh.v12n2-2.1780.
- Sverke, M. & Kuruvilla, S. 1995. A new conceptualization of union commitment: Development and test of an integrated theory. *Journal of Organizational Behavior* 16(6): 505-532.
- Thien, Lei Mee. (2019). Distributive leadership functions, readiness for change, and teachers’ affective commitment to change: A Partial Least Squares analysis. *SAGE Open* 9(2). doi: 10.1177/2158244019846209.
- Thien, Lei Mee, & Meow Yem Tan. (2019b). Kepimpinan distributif, keadaan dalam sekolah, dan komitmen guru untuk berubah: Satu analisa Partial Least Squares. 4(1):159–85.
- Vigneswary Muthiaha, Donnie Adamsa & Zuraidah Abdullah. (2019). Distributed leadership and teachers’ affective commitment in international schools. 3(2):22–40.
- Yaakub, Mohd Yusaini bin. (2017). Perubahan komitmen guru terhadap perubahan dalam organisasi di sekolah.”
- Zulkafli, N. & Mahbob, M.H. (2020). Pengaruh Faktor Motivasi terhadap Prestasi Kerja. *Jurnal Wacana Sarjana*, 1-11.



074-110

DOUBLE REDUCTION POLICY: THE PREFERENCES, THE CHALLENGES, AND RECOMMENDATIONS BASE ON HEADMASTER, TEACHERS, PARENTS AND CHILDREN PERSPECTIVE IN XIN JIANG

HU QI, Bity Salwana Alias
Faculty of Education, University Kebangsaan Malaysia,
43600 Bangi, Selangor, Malaysia
P125912@siswa.ukm.edu.my
60147173684

ABSTRACT

The Chinese Communist Party implemented the “double reduction policy” as a measure and foundation stone for implementing education policy. To foster the standard of living it will be significantly important to improve the quality of teaching, and school education besides improving the healthy growth of young children. The salient feature of this policy is the focus on the reduction of time commitment to homework and to lessen the burden of various training programs after school hours.

This policy is a long-term strategic plan for the education sector. The problem that has significantly withdrawn the attention of educational enterprises and parents, is the overburden of K-12 level students and the schooling system. This “burden reduction policy has been working in primary and secondary schools since the 1990s and is denoted as quality education. Quality education makes up the wholeness of educational philosophy. The characteristics of education policy include (Wang, n.d.) exemption from entrance exams for primary school students, cancellation of rankings and reports, and other practices that help in burden reduction. This policy not only helps improve student quality by lessening homework, reducing examination difficulties, and improving evaluation techniques but also guides teachers in the various school systems to promote the implementation of quality education. (Wang, n.d.).

Keywords: Double Reduction Policy, Preferences, Challenges, Recommendations, Parents Concept.

1.1 INTRODUCTION

As perceived by the masses, the "Double reduction policy", aimed to benefit primary and junior high school students because firstly it reduces the burden of homework and secondly it reduces the burden of out-of-school training. Everyone looks forward to quality education because it is inevitable for survival in ever changing world. Modern education requires not to burden the children with homework and out-of-school training so that children use their potential at the stage of compulsory education (Cui, 2022).

The reason for reducing out-of-school training is the influence that it exerts on academic competition in China. To improve children’s academic performance increased parents are trying to arrange extra courses for their children increasing in off-campus training institutions.



The adverse point of the off-campus training institutions is that they are not academically qualified. Moreover, such institutions engage in false publicity, arbitrary fees, and other illegal practices. This poses a threat normal educational ecology of China (Li, J. et al., 2022). Not only this but these off-campus tutoring schools burden children academically and their families financially. Because of these after-school tutoring institutions academic competition in China has been intensified. In such off-campus institutes, emphasis is laid on exam-oriented education which in turn attracts more parents and students to join. More students take these courses to avoid falling behind others in the school's general exams or the Gaokao (Zhou, 2023).

1.2 THE CONCEPT OF DOUBLE REDUCTION POLICY

On 24 July 2021, the General Office of the Central Committee of China's Communist Party and the General Office of the State Council jointly released the 'Double Reduction' policy, to further reduce the homework and off-campus training burden for compulsory education students. The policy can be categorized into three fundamental areas of focus regarding off-campus training institutions. These three areas are requirements for the approval of institutions, strengthening the standardisation of the operation of training institutions and standardising the training content and method of training (Li, J. et al., 2022).

It is a policy requirement that these off-campus subject-based training cannot be held during summer and winter vacations, rest days or during China's national holidays. Therefore, many families do not allow their children to participate in these training courses because children need to complete school tasks on weekdays and thus there is no extra time to take part in these trainings. Reforms in the 'Double Reduction' policy made weekends of children free from stressful academic training facilitating their overall growth.

These reforms in the 'Double Reduction' policy resulted in the rectification of offcampus training institutions and school education once again became the dominant education in China. It is an opportunity and a challenge at the same time. To meet the individual learning needs of different students, this off-campus training is useful because all types of students attend this off-campus institute. Those who are behind in school can improve their scores by advanced knowledge while those who already have a good understanding of the subject or have good grades still improve by participating in activities like the mathematical Olympiad, (Li and Tian 2021). This has posed the biggest challenge to schools to fill up the gap left by off-campus training and to establish a schoolwork system to meet the learning needs of these students (Zhou, 2023).

The government has introduced many reforms for public schools. Now the public schools are required to provide after-school services and support clubs, sports and art and social activities after formal school hours. In these after-school services, teachers help and guide students in completing written homework assignments and cannot teach any courses (Li, J. et al., 2022). These reforms in school services influenced student development. Because now the students not only complete school assignments on time but can also participate in various school activities. These after-school services help students complete their homework at school, so they have quality time to spend with their families (Li, J et al., 2022). (Zhou, 2023)



1.3 THE DEVELOPMENT OF DOUBLE REDUCTION POLICY

There are certain reasons behind the release of the double reduction Policy, especially some negative social phenomena. The foremost reason is that education and training institutions are increasing in society at a rapid growth rate. These training courses are more costly than an average hourly wage lay a heavy burden on financially weak families and induce anxiety in parents with their advertising slogans. Because it makes parents compare educational investment and the blind pursuit of high scores and forces them to over-invest in their children's education. Although family planning has been abolished in China, for the last two years the fertility rate has not increased significantly. The reason is the economic pressure of educational investment. (Cui, 2022)

The main objective of national education is to improve the national literacy rate, improve the comprehensive strength of the country and inherit national civilization and not to score good grades in examinations only. The educational and other industries should be balanced. Education should be able to promote basic industries and high-end manufacturing industries, rather than competing with other industries for resources.

The abnormalities in the education industry have significantly influenced the purchasing power of common families. The result of this decline in people's purchasing power weakened market mobility, insufficient funds for education and other industries development of industries that a country needs to develop resulting in slow industrial development(Cui, 2022).

1.3.1 Education inequality in China :

China experienced a rapid growth of the higher education system, by an increase in educational opportunities (Wu et al., 2020). This growth and expansion in higher education resulted in elevated expectations of entry standards by the job market and graduate schools. This trend supported elite institutions and students from these institutions. However, opportunities for entering higher education are still seriously limited due to differences in various dimensions against the backdrop of Chinese society (Jia and Ericson, 2017). The Chinese culture being a complex entity has always been re-examined, reconfigured and sometimes revitalised (Louis, 2008). (Zhou, 2023).

In China, education is linked with economic success and social status because of its old traditions and culture. The students must bear the burden of studies to compete with their peers and to meet the expectations of the parents, (Lin and Chen, 1995). The main objective of the education is to prepare the students for examination. Therefore, Preparation for the Gaokao usually begins as early as the first grade of middle school and continues throughout secondary school, (Burkhoff, 2015). In China, there is a wide variety of examinations like mid-term examinations, final examinations, citywide unified examinations, and provincial unified examinations (Lin and Chen, 1995). In secondary schools, students take regular exams sometimes every day or three to five days. The competition among the schools and teachers is based on scores of students to obtain the highest admission rate, (Lin, 1993). Besides frequent tests, there is a burden of homework on the children. Due to heavy homework children reduce sleeping time to complete it. 38% of primary and secondary school students go to bed late and 67% do not get enough sleep (Li et al., 2022). Moreover, because of economic, political, and cultural factors, a competitive academic environment is developed. It becomes the



responsibility of parents to guide their children to achieve excellent academic results (Quach et al., 2015). (Zhou, 2023)

Many Chinese students suffer from depression and mental ill-health because of the dual pressures of home and school. The children suffer from this depression because of the stress to get good grades in Gaokao which is held in the later stage of adolescence. Before that students suffer from this problem because adolescence is a period of vulnerability and they are too young to take it (Fu et al., 2021). Hesketh and colleagues (2010) found in a study conducted on 2,191 urban and rural Chinese children aged 9–12 that 81% of the children were ‘very worried’ about the exam, 63% were afraid of being punished by the teacher and 73% experienced corporal punishment from their parents for their lax learning. Some studies also revealed that older Chinese adolescents are at higher risk of suicidal thoughts and attempts due to increased academic pressure, (Cheng et al., 2009; Cui et al., 2011). However, some recent studies (Liu et al 2020), revealed that some students believed that the Gaokao was a motivational goal for students and better than studying in a system without any motivation. It is important to note that the negative effects of academic stress may not remain limited to an individual’s mental health only but also affect relations with peers and attitudes towards society and authority. (Zhou, 2023)

1.4 POLICY-RELATED

1.4.1 Chinese education system

In Chinese culture, the pressure to obtain high academic achievement is generated because of society and culture. Because education is perceived and demanded by society, (Zhou, 2023). Therefore, since ancient times, examination and competition have been considered particularly important, particularly to entering higher education. In China, the imperial examination system lasted for around 2000 years. It has been considered the only way to change social class since the Han dynasty. (Meng-Ying, 2021).

The government used the examination to select officials to govern the country. The scholars who successfully passed the examination were given prestige, titles, power, and land so that they and their families benefitted from prosperity generation after generation (Lin and Chen, 1995). Therefore, persons with high intellect but low income needed to excel in the examination to improve the social status of their families and themselves. As the criterion of selection in China is the examination, therefore high-level education, is linked with social status. Failure at the school level is a source of shame and embarrassment for families, individuals and even the country (Davey et al., 2007). China’s education system and culture are greatly influenced by this tradition of pressure to climb the social ladder through education. (Zhou, 2023)

1.4.2 Quality Education (Suzhi Jiaoyu)

To achieve equity in education, China’s government introduced the 9-year compulsory education system in 1986. Its objective was to ensure that every school-age child must receive a quality education and a certain degree (Tian & Li, 2002). This compulsory education policy made education possible for those who lacked education resources and had access to a restricted number of activities. Later several policies offered some support for the latter aspect. In 1988, The Chinese government showed concerns about the burden on primary students and the Chinese State Education Commission (the predecessor of the Chinese Ministry of



Education/ [MoE]) issued Provisions for alleviating the learning burden of primary school students. These provisions (State Education Commission, 1988) directed public schools that their teaching should follow the curriculum plan by the local school board, prohibit teachers from tutoring after class, and limit the homework loads. The same authority promulgated instructions in 1998, focussing on character building of students and reducing the learning burden in compulsory education for Quality Education (Suzhi Jiaoyu). Moreover, in this instruction version, the method of using scores of enrolments to measure a teacher or a student was completely banned. The following year, the commission reiterated its opinions regarding the supervision of local governments, agencies, schools, and parents (MoE, 1994). The Ministry of Education introduced regulations from different perspectives like reducing the learning burden of students in the following years in 2000, 2013(a), and 2016. The government of China has progressively been taking action at different levels related to this topic. (*Parents' Attitudes toward the Chinese "Double-Reduction" Policy*, 2023)

1.5 THEORY/MODEL RELATED

1.5.1 Teaching and Learning Theory

To support the double reduction policy the 3P theory of Janette B. Biggs regarding teaching and learning works as a theoretical framework. This theory guides teachers to make a connection between previous and recent teaching experiences to help students in improving their learning. The 3P theory identifies the learning process into three categories. The first of these categories is presage, the second is process, and the third and last is the product. This theory was practically used for students from different sociocultural backgrounds and schools. Under this theory, different subjects like accounting, management, health and social care were also taught.

The first category is the presage phase involves individual learning preparation means the student's previous knowledge, and external preparation meaning the previous experience of teachers. In the presage phase, the individual's previous knowledge students brought into the learning experience and their expectations of the new learning experience. These are the characteristics of students like their previous knowledge, values, and new expectations. The students have their stable ways of learning and interests. Teachers' previous experiences mean their professional academic ability, teaching style, course design ability, classroom climate and skills. Both the internal and external learning preparation variables exist before classroom learning (Id & Wang, 2023).

The second phase is the process phase. This phase emphasizes the development of learning methods by the student after class teaching is over. This phase involves the changes in students' passive learning at the end of the interaction between student and external learning preparation factors. In this phase student develops different learning motivations, leading him to select different learning strategies and methods. The selection of learning strategies depends on the student and how he perceives it mastering new knowledge (Id & Wang, 2023).

The product phase is the final phase. Here the word product referred to the learning efficiency and performance of the students. The achievements later impact the learning motivation and involvement of the students. The students can analyse and evaluate their learning strategies, and the appropriateness and reset them as per requirement. Based on students' learning



outcomes, teachers can also evaluate their teaching skills and modify them accordingly (Id & Wang, 2023).

The interwoven three phases of the 3P learning model presented a dynamic learning mechanism. In this model, both individual and external preparation factors that is individuals and teachers, collectively contribute to the learning motivation of the students and the metacognitive activity of students. Thus, providing him with awareness of his learning methods in further learning.

In this way learning methods of students which affect student’s learning achievements, will improve. Learning methods mediate the relationship between learning preparation and learning achievement. The 3P theory is a cyclic process that helps us understand the whole process of learning (Id & Wang, 2023).

1.5.2 Maslow’s hierarchy of needs theory (1943)

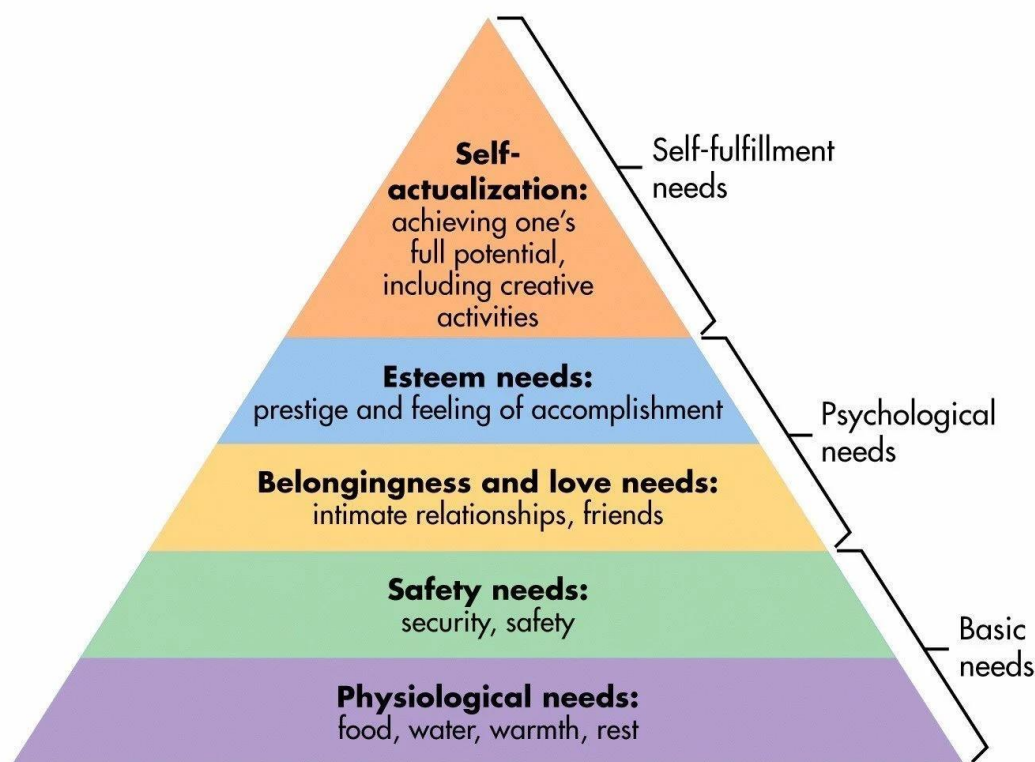

Maslow presented his theory of Hierarchy of Needs in 1943. The theory describes that individuals prioritize their needs and satisfy them hierarchically (Brooks, 2006, p. 55).

Maslow stressed to solve or fulfil specific needs, thoughts originate in person and these thoughts figure out his behaviour (Koçel, 2010, p. 623). Maslow formed a pyramid of hierarchy of needs to explain his theory where needs from the base level of this hierarchy (Maslow, 1954, p.80). an individual’s needs can be physiological, belonging and love needs, safety needs, self-actualization needs and self-esteem needs. It is impossible to go up to the next level of hierarchy without satisfying at least one need on the base, (Maslow, 1954, p.98). It is noteworthy that according to Maslow no need can be satisfied completely, and a satisfied need no longer motivates the individual for further action (Özkalp and Kirel, 2005, p. 318). In this pyramid of



hierarchy, needs related to personal development are at the top-level and the physiological needs related to deficiency or requirements come later (Brooks, 2006, p. 14). The needs can be categorised as food, water, sleep, and sex are physiological needs. Everyone needs to be accepted and loved by his/her family, social circle, and friendship. The safety needs include the protection of property and work and the security of life from physical and emotional threats. For an individual's self-esteem respect is needed to decide on his own, achievement, recognition, drawing attention and status, (Turabik & Atanur, 2015).

While in some studies of organization management, the association of needs is different. Like physiological needs would be concerned with, wage and occupational safety. Similarly, safety needs will be related to sick pay, unfair situation prevention, pension plans, and physical security. Likewise need for love and belonging in the business organisation would refer to acceptance by the colleagues and administration, a feeling of belonging to the organization, to being loved by those and his relationship with them while respect means respect from friends and managers, work progress and appreciation by the managers.

Making the best use of his potential as a worker and continuously improving himself are self-actualization needs(Turabik & Atanur, 2015).

According to the theory of hierarchy of needs, individuals will determine their behaviour and efforts to satisfy their needs (Koçel, 2010, p. 62; Turabik & Atanur, 2015). School teachers say that according to Abraham Maslow's needs theory the level of attainment of lower level needs and higher level needs is not high, it is the low level of attainment of belongingness needs and emotional needs as well as self respect and recognition. The impact on teacher motivation is the decline in the quality of teaching. After the implementation of the double cut policy, many schools increased working hours, but did not increase salaries. Most importantly, the government should resolve to improve the existing facilities and working conditions in the school system, This will increase teacher participation and productivity.

1.6 PREVIOUS STUDY

1.6.1 Teacher education reform in China since 1978 (ANPING SHEN,1996)

In the light of historical and sociopolitical perspectives, there is no doubt that changes in society and schools strictly demand teacher education. The burden lies on the shoulders of policymakers concerning teacher education to revise, update, and reform teacher education curricula. The current higher education system is also in need of reforms. However, there is no room for radical reforms like the format employed in the Cultural Revolution. It is a need for an hour in China to critically assess its historical and modern legacies besides reevaluating Western thoughts of social and educational reforms to benefit China for reforms. In China, needs must move forward towards modernization, (Genliang Jia,2024). Under the dominating influence of Western mainstream economics in the Chinese, questioning by Chinese academic institutions is the only local question.

It is important to note that Western mainstream economics in Chinese universities has become more dominant than in 2016. At the national level, although the central government has recognized the problems existing in economic education, no effective measures have been taken. Those who built their careers on Western mainstream economics, or the neoliberal paradigm are now in the leadership positions of universities and economics departments in China. They are the main source of strong resistance to bringing up reforms in the economics



education system. The junior faculty in universities are not interested in reforms as the dominance of the Western mainstream economics paradigm as a “belief” is absolute with problems in the economic education system at the point of “no return” because the frozen ground cannot be thawed in a single day. Therefore, reform in the Chinese economic education system would be a long and laborious process to occur. (Jia, 2024)

1.6.2 Reflections on Economics Education in China and Suggestions for Its Reform (Genliang Jia,2024)

According to (Jia Zhenliang, 2024) the "statement" of "Economic Research and Management World" represents only sporadic and partial skepticism by Chinese academic institutions regarding the dominant influence of Western mainstream economics in the Chinese economics community. Recently, I conducted telephone interviews with the following people: four senior, middle and junior scholars engaged in teaching and research of political economy, economic history and history of economic thought agreed that Western mainstream economics in Chinese universities There has been no decline in the dominance of. , but refused. One interviewee explained that at the national level, although the central government has recognized and addressed the problems that exist in economics education, it lacks effective measures. Leadership positions in universities and economics departments across the country are dominated by individuals who have built their careers on mainstream Western economics or neoliberal paradigms. They are very opposed to the reform of the economics education system and their resistance is very strong.

At the level of junior teachers, there is no movement for reform because the mainstream Western economic paradigm has completely dominated as the "belief" within teachers. There is little “collective” support for diversity reforms in economics education.

The problems in China’s economics education system have almost reached the point of no return. It is not difficult to see that the frozen ground cannot melt in one day. The reform of China's economics education system is not a problem that can be solved solely by the speeches of national leaders, but a problem that must be solved. This will be a long and arduous process.

1.6.3 Higher Education Reform in China Today(OUYANG KANG,2004)

The Reform of the Employment System for University Teachers University teachers in the past, were also employed in universities for life like other government officers. However, there is a visible change in the government and social management sector while the situation of university lecturers is the same. Previously employment and professional evaluation were combined and performed together. For faculty evaluated a lecturer first is to be promoted to professor level and then employed as a full professor. This evaluation is an important lifeline for the lecturers in Chinese universities.

However, in this evaluation, there are many conflicts and contradictions between lecturers. Because, once a professor or associate professor, they are not going to lose their job, regardless of their performance. A new system of choice and promotion of faculty is under consideration in some advanced universities. Now the achievements in teaching and research will be one of the criteria(Kang, 2004).

1.6.4 Suzhi Education and General Education in China (Haishao Pang, Meiling Cheng, Jing Yu, and Jingjing Wu, 2020).



The Soviet model and specialist training highly influenced Chinese higher education. There are many problems in *such* education and general education about changing education ideas. For instance, the teaching concepts and methods reforms, changing and organizing administrative systems. Education is individual-oriented educational goals or society-oriented educational goals. In Chinese universities main problem to be solved is the shifting of education aims from society-oriented to individual-oriented, so that *suzhi* education and general education and reforms mode could be set up. (Pang et al., 2020).

1.6.5 Review of China's Online Education Policy, 1999–2022 (Yu Jiang, Junjie Shang, and Lizhen Jiao, 2023)

During the pandemic, schools needed to use technology platforms for comprehensive online education. Though the teaching and learning process remained asynchronous and different time spaces, (Cui et al., 2020). It was not a problem to set up online education because of technological development, yet there were some deficiencies. For instance, problems in building long-term digital education resources, teachers' ability to online teaching, limited access of students to online learning, and teachers' inability to engage students in online teaching. To solve the issues, MOE released some guidelines and policies about the making and application of online resources, a project to improve the information technology application abilities of teachers and the construction of new educational infrastructure. The goal of developing online education and building a lifelong learning system within the education system is still in practice. The Double Reduction policy exerts pressure on online education. It is not to suppress online education but to promote online education and education ecology (Jiang, 2023).

In China, online education development is categorised into four categories. The objective of the study is to understand its empirical description and analysis of the policies. In online education students can independently select the learning content and level, ways of presentation, and communication methods most suitable for them, thus providing a form of education accessible to everyone (Jiang, 2023).

1.7 SUMMARY

It can be summarized that the double reduction policy is a for fulfilling the fundamental task of fostering people's standard of living and improving the quality of school education and teaching. However, from existing literature, we can see this policy also faces some challenges, we need to explore it. From some previous study, We need to know how they reformed and learn from their experience

REFERENCE

- Castillo-montoya, M. (2016). *Preparing for Interview Research: The Interview Protocol Refinement Framework*. 21(5), 811–831.
- Chen, G., Oubibi, M., Liang, A., Zhou, Y., & Chen, G. (2022). *Parents' Educational Anxiety Under the " Double Reduction " Policy Based on the Family and Students ' Personal Factors Parents ' Educational Anxiety Under the " Double Reduction " Policy Based*



- on the Family and Students ' Personal Factors.
<https://doi.org/10.2147/PRBM.S370339>
- Cui, Z. (2022). *A Study on Whether CHina's Double Reduction Policy Is Beneficial to Vulnerable Families* (pp. 1541–1547). https://doi.org/10.2991/978-94-6463-036-7_229
- Fu, C., Ou, H., Mo, T., & Liao, L. (2023). Effect Mechanism of Extracurricular Tuition and Implications on “Double Reduction” Policy: Extracurricular Tuition Intensity, Psychological Resilience, and Academic Performance. *Behavioral Sciences*, 13(3). <https://doi.org/10.3390/bs13030217>
- Guo, J. (2023). *Opportunities , Challenges and Suggestions of After - School Services in Primary and Secondary Schools under the Background of " Double Reduction "*. 5(1), 5–8.
- Id, M. H., & Wang, L. (2023). *The relationship between Chinese university students ' learning preparation and learning achievement within the EFL blended teaching context in COVID-19 post-epidemic era : The mediating effect of learning methods*. 1–25 .<https://doi.org/10.1371/journal.pone.0280919>
- Jia, G. (2024). *Reflections on Economics Education in China and Suggestions for Its Reform* *. <https://doi.org/10.1177/00977004231194699>
- Jiang, Y. (2023). *Review of China 's Online Education Policy , 1999 – 2022*. 160, 1999–2022. <https://doi.org/10.1177/20965311221099581>
- Jorge Segovia Bonet. (n.d.). why parentts choose NON-dDENOMINATIONAL PRIVATE SCHOOLS FOR THEIR CHILDREN:PREFERENCE IN INTERNATIONAL SETTING. *ProQuest*.
- Kang, O. (2004). *Higher Education Reform in China Today*. 2(1), 141–149.
- Liu, Z., Duan, X., Cheng, H., Liu, Z., Li, P., & Zhang, Y. (2023). *Empowering High-Quality Development of the Chinese Sports Education Market in Light of the “ Double Reduction ” Policy : A Hybrid SWOT-AHP Analysis*.
- Lu, J., Tuo, P., Pan, J., Zhou, M., & Zhang, M. (2023). *Shadow Education in China and Its Diversified Normative Governance Mechanism : Double Reduction Policy and Internet Public Opinion*.
- Niancai, L., Zhuolin, F., & Qi, W. (n.d.). *Education in China and the World*.
- Pang, H., Cheng, M., Yu, J., & Wu, J. (2020). *Suzhi Education and General Education in China*. 3(15), 380–395. <https://doi.org/10.1177/2096531120913171>
- Parents' Attitudes toward the Chinese “Double-Reduction” Policy*. (2023).
- Reserved, A. R., Url, O., & Uri, E. (2020). *SAGE Research Methods Foundations Metadata*. 2019, 0–2. <https://doi.org/10.4135/Official>
- Turabik, T., & Atanur, G. (2015). The Importance of Motivation Theories in Terms Of Education Systems. *Procedia - Social and Behavioral Sciences*, 186, 1055–1063. <https://doi.org/10.1016/j.sbspro.2015.04.006>
- Wang, Q. (n.d.). *Understanding China 's Double Reduction Policy on Educational Economy*. 63–70.
- Wu, M. (2023). *The Phenomena and the Formation of Parents ' Anxiety under ‘ Double Reduction ’ Policy*. 8, 755–760.
- Yang, L., He, L., & Huang, N. (2023). A Study of Current Situation of Knowledge, Attitude, Beliefs and Practices of “Double Reduction”Policy Among Primary and Secondary School Teachers in Chenzhou City. *Frontiers in Artificial Intelligence and Applications*, 370, 289–301. <https://doi.org/10.3233/FAIA230195>
- Zhang, S., Binti, N., Hassan, C., Manisah, R., & Sulong, B. (2023). *Whether the " Double Reduction " Policy Reduces Parents ' Anxiety Over their Kids Future : A Qualitative Research from China*. March. <https://doi.org/10.6007/IJARPED/v12-i1/16322>



- Zheng, J. (2022). *The Transformation of Parents ' Perception of Education Involution Under the Background of " Double Reduction " Policy : The Mediating Role of Education Anxiety and Perception of Education Equity.* 13(May). <https://doi.org/10.3389/fpsyg.2022.800039>
- Zhong, K., & Park, J. (2023). *The double reduction policy and education development in China.* 25(3), 137–152. <https://doi.org/10.1108/IJCED-09-2022-0063>
- Zhou, Z. (2023). *The Attitude of Chinese Parents Towards The ' Double Reduction ' Policy and The Factors Influencing Their Attitude.* 6(1).



133-111

SINTESIS KEPIMPINAN TRANSFORMASIONAL UNTUK MENINGKATKAN EFIKASI KENDIRI DAN KEPUASAN KERJA GURU DI ORGANISASI PENDIDIKAN

Rapiza Binti Miswan
Fakulti Pendidikan

Universiti Kebangsaan Malaysia, 43600, Bangi, Selangor, Malaysia
Emel: p130283@siswa.ukm.edu.my, Tel: 019-2721204

Prof. Madya Dr. Bity Salwana binti Alias
Pusat Kajian Kepimpinan & Polisi Pendidikan
Universiti Kebangsaan Malaysia, 43600, Bangi, Selangor, Malaysia
Emel: bity@ukm.edu.my, Tel: 012-3725032

ABSTRAK

Kepimpinan transformasi dicirikan dengan menggalakkan dan memberi inspirasi kepada orang ramai untuk menginovasi diri mereka, seterusnya menyumbang kepada pertumbuhan dan kejayaan organisasi. Manakala, efikasi sendiri ialah tahap keyakinan seseorang terhadap keupayaan dirinya untuk mencapai sesuatu kejayaan atau matlamat. Kepuasan kerja adalah perasaan subjektif, reaksi atau perasaan seseorang terhadap pekerjaan mereka. Antara isu yang dibincangkan dalam amalan kepemimpinan transformasional guru besar ialah dimensi pertimbangan berasaskan individu. Dalam pertimbangan berasaskan individu, guru besar memberi peluang kepada guru-guru untuk menyatakan cadangan, memberi penghargaan kepada guru, menyatakan pujian dan mendengar serta menerima cadangan guru-guru. Dimensi pertimbangan berasaskan individu merupakan dimensi yang paling digemari, diikuti motivasi berinspirasi dan dua lagi dimensi yang lain. Tujuan perbincangan ini adalah untuk mengenalpasti hubungan antara kepemimpinan transformasional untuk meningkatkan efikasi sendiri dan kepuasan kerja guru. Rumusannya, berdasarkan kerangka teoretikal didapati hanya dua dimensi daripada efikasi sendiri guru dan kepuasan kerja guru yang selari dengan kepemimpinan transformasional. Oleh itu, amalan kepemimpinan yang lain didapati lebih sesuai dengan dimensi-dimensi yang terkandung dalam kedua-dua pembolehubah yang telah dipilih bagi sintesis ini.

Kata Kunci: Kepimpinan Transformasional, Efikasi Kendiri Guru, Kepuasan Kerja Guru.

PENGENALAN

Guru besar mempunyai peranan penting dalam menentukan hala tuju dan pengurusan sekolah. Hasrat KPM untuk menempatkan pemimpin berprestasi tinggi di sekolah juga tergambar dalam anjakan ke-5 PPPM 2013-2025. Pemimpin transformasional ialah individu berwawasan yang mencabar, mengiktiraf dan menghargai pengikut mereka serta menggalakkan mereka menjadi individu yang kreatif dan inovatif. Mereka memberi tumpuan kepada membina budaya pemilikan dan autonomi syarikat yang kukuh di tempat kerja. Kepimpinan transformasi juga merujuk kepemimpinan yang berjaya dalam mereformasi atau mengubah orang bawahan untuk



mencapai matlamat, melalui kepercayaan orang bawahan kepada pemimpin, melakukan sesuatu untuk mencapai matlamat, bermotivasi tinggi untuk bertindak bergerak untuk mencapai matlamat peringkat tinggi. Dalam institusi pendidikan seperti sekolah, guru besar merupakan penggerak utama kepada pertumbuhan dan kemajuan sesebuah sekolah. Kepimpinan transformasional mesti dilaksanakan oleh guru besar sekolah rendah kerana ini adalah kunci untuk membangunkan sekolah yang mempunyai kepimpinan. Menurut Vijian dan Jamalul Lail (2020) berpendapat bahawa kepimpinan transformasi adalah penting untuk membentuk organisasi yang berkesan.

Pengamalan kepimpinan transformasional boleh menyedarkan guru tentang kepentingan matlamat, menggalakkan mereka mengutamakan sekolah, dan memberi semangat kepada mereka untuk mencapai transformasi pendidikan di sekolah (Lau dan Mohamed, 2020). Guru yang berfikiran kreatif dan inovatif, bermotivasi tinggi dan bersedia untuk mengambil bahagian sepenuhnya dalam aktiviti tersebut boleh dilahirkan di bawah kepimpinan transformasional. Keyakinan terhadap kompetensi guru adalah sangat penting. Menurut Nurul Husna dan Jamalullail (2021), antara faktor yang menentukan prestasi seseorang guru itu ialah efikasi guru tersebut. Sebagai seorang guru, guru harus mempunyai matlamat dan wawasan yang hendak dicapai dalam pekerjaannya. Bagi mencapai hasrat atau sesuatu matlamat, guru harus tahu dan yakin dengan kebolehan diri sendiri. Oleh itu, efikasi sendiri yang tinggi boleh memberi banyak kesan positif dalam kehidupan seharian, seperti daya tahan menghadapi tekanan dan penderitaan, pilihan gaya hidup sihat, peningkatan prestasi kerja dan kejayaan dalam pendidikan. Tahap efikasi sendiri guru dapat dilihat melalui keyakinan guru dari sudut pengurusan bilik darjah (Gan dan Mohd Izham, 2023). Selain itu juga, perancangan dan pelaksanaan PdP serta melibatkan murid dalam aktiviti kelas juga menunjukkan keyakinan guru dalam melaksanakan tugas yang diberi. Oleh itu, keyakinan terhadap kebolehan guru tidak boleh diabaikan malah perlu diberi tumpuan bagi meningkatkan pencapaian pelajar dan akademik. Oleh itu, kepuasan kerja guru amat penting bagi memastikan operasi sekolah berkesan. Guru akan lebih bersemangat atau bersungguh-sungguh dalam menjalankan tugas sekolah apabila mereka berpuas hati dalam kerja mereka. Secara umumnya, kepuasan kerja merupakan faktor yang boleh mempengaruhi prestasi seseorang di tempat kerja selain faktor efikasi guru.

Analisis Artikel 1: Amalan Kepimpinan Transformasional Guru Besar dan Efikasi Kendiri Guru SJKC

Pengenalan

Teori Kepimpinan Transformasional Burn (1978)

Pada tahun 1978, Burns telah memperkenalkan konsep kepimpinan transformasi dalam masyarakat dan amalan ini mula diaplikasikan oleh perniagaan di negara barat. Kepimpinan ini sesuai dan dianggap sebagai satu transformasi dalam pengurusan dan pentadbiran kerana ia boleh mengubah struktur sesebuah organisasi daripada sistem kawalan berpusat kepada semua orang bawahan mempunyai kuasa untuk membuat keputusan. Kuasa mutlak tidak lagi digunakan oleh pemimpin organisasi tetapi keputusan dibuat secara kolektif dan konsensus pengikutnya. Perspektif dan perbezaan setiap individu dalam organisasi adalah sangat penting. Pemimpin transformasi menggalakkan pengikut untuk meletakkan kepentingan organisasi melebihi kepentingan mereka sendiri. Dalam kajian yang dilakukan oleh Adrience dan Mohd Yusoff (2022) menyatakan bahawa terdapat empat dimensi dalam kepimpinan transformasional



yang ditekankan oleh Bass. Dimensi-dimensi tersebut ialah pertimbangan berasaskan individu, motivasi berinspirasi, rangsangan intelektual dan pengaruh yang ideal.

Model Kepimpinan Transformasional Slocum & Hellriegel (2007)

Menurut Gan Yin dan Mohd Izham (2023), model yang mendasari kajian mereka ialah model Slocum dan Hellriegel (2007) yang meliputi empat dimensi. Empat dimensi yang diberi fokus ialah pertimbangan berasaskan individu, motivasi berinspirasi, membina rangsangan intelektual dan memupuk pengaruh yang ideal dalam organisasi.

- a) Memupuk pengaruh yang ideal: pemimpin transformasional adalah seseorang individu yang dapat memimpin kelakuan pengikut-pengikutnya dan menjadi perangsang kepada khalayak ramai.
- b) Pertimbangan individu: Pemimpin bersifat pertimbangan individu dapat dilihat melalui kelakuannya yang sanggup memberi perhatian kepada setiap ahli organisasi
- c) Motivasi berinspirasi: Pemimpin mempunyai motivasi berinspirasi yang tinggi dan mampu menyatakan visi dan misi yang menarik supaya dapat menggalak pengikut-pengikutnya untuk berubah.
- d) Membina rangsangan yang intelektual: Pemimpin mengurus dan menyelesaikan masalah, menyahut cabaran dan memimpin pengikut-pengikut untuk berfikir dan membina idea-idea yang baharu.

Menurut Sainah, Aminuddin dan Judith (2021), asas utama Model Kepimpinan Slocum dan Hellriegel melibatkan keupayaan pemimpin mempengaruhi pengikutnya melalui amalan tingkah laku kepimpinan. Mereka juga berpendapat bahawa model ini memberi peluang kepada guru untuk berkembang secara profesional dalam memberikan tindak balas melalui persekitaran yang sesuai dengan model kepimpinan jenis ini.

Dapatan kajian lepas berkenaan kepimpinan transformasional guru besar dan pengetua menunjukkan guru besar dan pengetua mempunyai tahap kepimpinan transformasional yang tinggi (Claudia & Norazah, 2023; Jamal, Marinah & Mahaliza, 2019; Kartini, Aida Hanim & Norasmah, 2022). Guru besar di sekolah transformasi 25 di Jerantut mengamalkan ciri-ciri kepimpinan menurut elemen-elemen yang terdapat dalam kepimpinan transformasi seperti bekerja bersungguh-sungguh, bersemangat tinggi, berani menanggung risiko dan sentiasa memberikan rangsangan positif kepada guru-guru (Kartini, Aida Hanim dan Norasmah, 2022). Sainah, Aminuddin dan Judith (2021) berpendapat bahawa kepimpinan transformasional guru besar memberi impak yang besar terhadap kecemerlangan organisasi secara berterusan. Faktor-faktor seperti keperluan dan persekitaran sekolah serta guru-guru turut diambil kira untuk disesuaikan dengan corak dan gaya kepimpinan transformasional agar selari dengan elemen-elemen yang terdapat dalam corak kepimpinan seperti itu.

Pelopor

Teori kepimpinan transformasi ini diperkenalkan oleh Burns pada 1978. Teori ini mengambil ilham daripada teori kepimpinan karismatik yang dihasilkan oleh Robert House (1976). Seterusnya, pada tahun 1985, Bass dan rakan-rakannya membangunkan model kepimpinan transformasi dan cara untuk mengukurnya (Bass & Riggio, 2008). Bass memberi tumpuan kepada pengikut dan bukannya pemimpin. Bass juga mengembangkan penyelidikan House dengan memfokuskan pada faktor emosi dan punca tarikan.



Kepentingan

Nurul Husna dan Jamalullail (2021) mendapati daripada kajian yang dijalankan bahawa pemimpin transformasi memotivasikan kakitangan mereka untuk melampaui jangkauan dan memberi tumpuan kepada keperluan guru. Pemimpin transformasi juga turut bertindak sebagai juru pandu dan penasihat serta memberi tumpuan kepada pembangunan dan perkembangan pembelajaran. Mereka juga mewujudkan persaingan untuk mencapai misi, menimbulkan rasa sayang dan rasa hormat kepada rakan guru, serta menjadi contoh kepada guru lain.

Selain itu juga, pemimpin sekolah memainkan peranan penting sebagai pemimpin transformasi, yang mesti menggunakan pelbagai pendekatan untuk membantu guru mengenal pasti masalah yang dihadapi dalam perubahan pendidikan yang dibawa oleh pandemik Covid 19 serta cara menyelesaikan masalah ini (Adrience & Mohd Yusoff, 2022). Tambahan lagi, menurut Lina Fung dan Azlin Norhaini (2022), amalan kepimpinan transformasi pengetua memberi impak positif terhadap kepuasan kerja guru terutamanya semasa pandemik Covid-19.

Pentadbir sekolah bukan sahaja terdiri daripada guru besar atau pengetua semata-mata tapi turut disertai dengan Penolong Kanan. Menurut Nurul Husna dan Jamalullail (2021), Guru Penolong Kanan Kokurikulum (GPKKo) yang mengamalkan kepimpinan transformasi berperanan sebagai perancang dan mengatur dalam menyediakan takwim aktiviti kokurikulum sekolah, menyediakan kegiatan kokurikulum dan menyusun jadual bagi latihan-latihan yang berkaitan dengan kokurikulum. Dengan ini, GPKKo perlu hadam dan menghayati bidang atau skop tugasnya dengan mendapat dokongan daripada jawatan kokurikulum sekolah. Oleh itu, amalan kepimpinan transformasi mesti dijalankan dalam diri setiap sekolah, kerana gaya kepimpinan ini dapat membantu menjadikan pendidikan Malaysia lebih baik.

Penerangan Konstruk dalam teori

- Pertimbangan Berasaskan Individu

Pemimpin bersifat pertimbangan individu dapat dilihat melalui kelakuannya yang sanggup memberi perhatian kepada setiap ahli organisasi

- Motivasi Berinspirasi

Pemimpin mempunyai motivasi berinspirasi yang tinggi dan mampu menyatakan visi dan misi yang menarik supaya dapat menggalak pengikut-pengikutnya untuk berubah.

- Membina Rangsangan Intelektual

Pemimpin mengurus dan menyelesaikan masalah, menyahut cabaran dan memimpin pengikut-pengikut untuk berfikir dan membina idea-idea yang baharu.

- Memupuk Pengaruh yang Ideal

pemimpin transformasional adalah seseorang individu yang dapat memimpin kelakuan pengikut-pengikutnya dan menjadi perangsang kepada khalayak ramai.



Kesesuaian dalam konteks Pendidikan di Malaysia

Dalam kajian-kajian yang lepas menunjukkan kepimpinan transformasional berada pada tahap yang tinggi (Nurul Husna & Jamalullail, 2021; Gan & Mohd Izham, 2023; Jamal, Marinah & Mahaliza, 2019). Kepimpinan transformasi adalah penunjuk terbaik bagi pentadbir untuk memotivasikan guru dan meningkatkan lagi keberkesanan peribadi mereka. Pemimpin yang penuh inspirasi berfikir ke hadapan dan terus maju ke hadapan. Pemimpin jenis ini sentiasa mahukan yang terbaik untuk orang bawahannya dan juga untuk organisasinya. Mereka sentiasa memotivasi dan menggalakkan pengikut mereka untuk melihat perkara jangka panjang dan mempunyai matlamat yang jelas. Motivasi guru merupakan faktor penting yang berkaitan dengan beberapa pemboleh ubah dalam bidang pendidikan seperti motivasi pelajar, amalan mengajar, dan kepuasan kerja guru.

Menurut Sainah, Aminuddin dan Judith (2021), kepimpinan transformasional dapat meningkatkan kesediaan dan keupayaan guru dalam menyampaikan pendidikan yang berkualiti dengan bersandarkan digital dan teknologi. Dengan ini guru-guru dapat mempelbagaikan kaedah pembelajaran agar selari dengan dunia pada masa kini. Peluang yang diberikan kepada guru-guru dapat meningkatkan motivasi dan kepuasan kerja guru dalam kerjaya pendidikan. Ini secara tidak langsung mendidik guru-guru agar dapat menerapkan nilai-nilai murni yang baik dalam dunia pendidikan yang semakin mencabar pada masa kini.

Teori Kognitif Sosial

Teori kognitif sosial Albert Bandura menegaskan bahawa faktor sosial dan kognitif serta faktor seseorang memainkan peranan penting dalam pembelajaran. Faktor kognitif merangkumi jangkaan dan penerimaan pelajar terhadap kejayaan, dan faktor sosial merangkumi pemerhatian pelajar terhadap tingkah laku ibu bapa mereka. Albert Bandura adalah salah seorang pencipta teori kognitif sosial. Menurut Bandura, semasa pelajar belajar, mereka boleh mewakili atau mengubah pengalaman mereka secara kognitif. Bandura tidak bersetuju dengan tanggapan bahawa manusia boleh berfikir dan mengatur tingkah laku mereka sendiri. Sebab dan akibat dalam kehidupan setiap individu bukan sahaja bergantung kepada persekitaran, kerana manusia dan persekitaran saling mempengaruhi antara satu sama lain.

Model Tschannen-Moran dan Hoy (2001)

Penglibatan pelajar adalah tindakan di mana pelajar mengambil bahagian secara aktif dalam aktiviti sekolah. Penglibatan merangkumi pemahaman dan pembelajaran pelajar dalam tugas pembelajaran tertentu dan mewujudkan hubungan dua hala antara pelajar dan guru. Ini termasuk penglibatan dalam bentuk tingkah laku, emosi dan kognitif. Pelajar bertindak balas secara positif kepada guru, rakan sekelas, dan sekolah. Menurut Lian dan Tai (2021), pengurusan kelas merupakan satu strategi yang bertujuan untuk meningkatkan atau menggalakkan tindak balas pelajar yang diinginkan melalui pujian, dorongan, perhatian dan ganjaran. Ini termasuklah kesungguhan guru dalam mengawal kelas dan mewujudkan suasana pembelajaran yang kondusif. Persekitaran kelas yang teratur penting sebagai sebahagian daripada pembelajaran dan pengajaran yang berkesan. Guru-guru mengurus rutin bilik darjah, mengurus masalah disiplin pelajar dan mengurus bahan sumber pembelajaran. Guru dan murid menjaga dan mengurus segala alat dan kemudahan yang terdapat dalam kelas.



Dalam kajian yang dijalankan oleh Gan dan Mohd Izham (2023), terdapat tiga dimensi utama yang digunakan dalam Model Tschannen-Moran dan Hoy, iaitu strategi pengajaran, pengurusan bilik darjah dan penglibatan murid.

a) Strategi pengajaran

Keberkesanan guru dalam merancang, melaksanakan dan mengurus proses pengajaran dengan mengaplikasikan pelbagai kaedah dan pendekatan berdasarkan tahap penguasaan murid yang berlainan serta kebolehan guru untuk berhadapan dengan murid yang berlainan pencapaian.

b) Pengurusan bilik darjah

Kebolehan seseorang guru untuk mengurus dan mengawal bilik darjah secara berkesan, memastikan pembelajaran dan pemudahcaraan dijalankan dengan lancar, mengawal tingkah laku murid, menyelesaikan masalah disiplin murid dan memastikan semua murid dapat belajar dalam satu persekitaran pembelajaran yang kondusif dan selesa.

c) Penglibatan murid

Kebolehan seseorang guru menggalak murid-muridnya untuk melibatkan diri secara aktif semasa proses pembelajaran dan pemudahcaraan dijalankan.

Pelopori teori dan model

Teori kognitif sosial yang pelopori oleh Albert Bandura yang dilahirkan pada tahun 1925 di Mundare, Kanada. Beliau mula berkhidmat di Fakulti Psikologi di Universiti Standford pada 1953 dan menjadi Profesor Psikologi sepenuh masa pada tahun 2002. Beliau dipengaruhi oleh kajian Sears tentang behavioral sosial dan mula mengkaji tentang pengajian sosial. Beliau berkolaborasi dengan anak muridnya, Richard Walters mengemukakan proses modeling. Teori pembelajaran sosial telah dinamakan semula sebagai “Teori kognitif sosial” oleh Bandura sendiri (Moore, 2002). Teori pembelajaran sosial menyatakan bahawa faktor-faktor sosial, kognitif dan tingkah laku memainkan peranan penting dalam pembelajaran. Faktor kognitif akan mempengaruhi jangkaan pelajar tentang kejayaannya; sementara faktor sosial, termasuk pemerhatian pelajar tentang tingkah laku dan pencapaian ibu bapanya, akan mempengaruhi tingkah laku pelajar tersebut.

Model Tschannen Moran dan Hoy diperkenalkan oleh Megan Tschannen-Moran dan Anita Woolfolk Hoy pada 2001. Model ini diperkenalkan dalam artikel yang bertajuk “Teacher efficacy: Capturing an Elusive Construct”. Megan Tschannen-Moran adalah Profesor Kepimpinan Pendidikan di Sekolah Pendidikan William & Mary. Berpengalaman selama empat belas tahun sebagai pengasas pengetua sekolah yang berkhidmat kepada penduduk pelajar yang terutamanya berpendapatan rendah dan minoriti di kawasan bermasalah Chicago, beliau termotivasi untuk bekerja di persimpangan teori dan amalan supaya sekolah berkembang dalam keupayaan mereka untuk melayani semua pelajar dengan baik. Sementara itu, Anita Woolfolk Hoy menerima BA Magna Cum Laude pada tahun 1969 dari Universiti Texas di Austin, dengan major dalam Psikologi dan minor dalam Kimia. Pada tahun 1972 beliau dianugerahkan Ph.D. dalam Psikologi Pendidikan dari universiti yang sama. Profesor Woolfolk Hoy telah menerbitkan penyelidikan dalam bidang kognisi guru, persepsi pelajar terhadap guru, keyakinan guru, motivasi pelajar, dan aplikasi psikologi pendidikan kepada pengajaran.

Kepentingan Model

Terdapat tiga faktor yang dikemukakan oleh Tschannen-Moran dan Hoy (2001) bagi mewakili efikasi sendiri guru iaitu efikasi terhadap strategi pengajaran, efikasi terhadap pengurusan bilik darjah dan akhirnya efikasi terhadap penglibatan pelajar. Instrumen ini sangat bersesuaian dan



bertepatan sebagai pengukuran variabel efikasi sendiri guru dari aspek strategi pengajaran, pengurusan bilik darjah dan penglibatan murid (Roslee & Tisebio, 2020). Dapatan kajian yang dijalankan oleh pengkaji juga menunjukkan Teori Efikasi Kendiri Tschanen-Moran dan Hoy (2001) dan Model Efikasi Kendiri Guru Tschanen-Moran dan Hoy (1998, 2001) menyokong kajian yang dijalankan dan memberi pemahaman terhadap teori yang diperkenalkan kepada penyelidik yang menggunakannya.

Sementara itu, instrumen dalam model ini juga dapat memotivasikan guru untuk mengetahui dan mengembangkan kemahiran baharu yang membawa kepada pembelajaran yang lebih afektif untuk guru dan pelajar (Liang & Tai, 2021). Guru-guru juga dapat membuat peningkatan dalam kemahiran menguruskan bilik darjah dan pengurusan kelas.

Kesesuaian dalam konteks Pendidikan di Malaysia

Antara cadangan sistem pendidikan Malaysia ialah dasar Pendidikan guru. Dasar pendidikan guru ini merujuk kepada Dasar Pendidikan Kebangsaan (2012), yang memberi tumpuan kepada guru dengan menyediakan latihan perguruan bagi melengkapkan guru dengan pengetahuan, sikap, tingkah laku dan kemahiran yang diperlukan. Antara strategi teras ini ialah penyediaan guru terlatih yang berkualiti, cekap dalam aspek yang bernilai seperti profesionalisme keguruan, pengetahuan dan kefahaman pengajaran, serta kemahiran pengajaran dan pembelajaran berdasarkan Standard Guru Malaysia (SGM).

Kerangka teoretikal

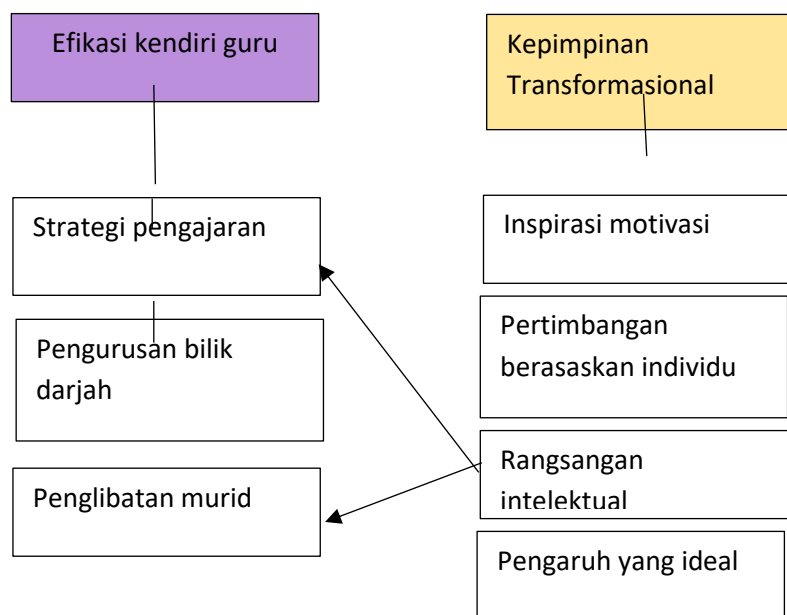

Berdasarkan kerangka teoretikal di atas, didapati dimensi inspirasi motivasi dalam kepimpinan transformasional tidak memenuhi syarat dengan mana-mana dimensi dalam efikasi sendiri guru. Hal yang sama turut berlaku pada dimensi pertimbangan berasaskan individu dan pengaruh yang ideal. Namun, hal yang bertentangan pula berlaku pada dimensi rangsangan intelektual. Terdapat keselarian antara rangsangan intelektual dengan strategi pengajaran dan penglibatan murid dalam efikasi sendiri guru. Daripada hubungan yang dapat dilihat daripada kerangka, didapati hanya satu dimensi dalam kepimpinan transformasional relevan dengan dua dimensi dalam efikasi sendiri guru. Ini menunjukkan kepimpinan jenis ini kurang sesuai dihubungkan dengan efikasi sendiri guru.



Walaubagaimanapun, dalam kajian-kajian yang lepas mendapati bahawa kepimpinan transformasional guru besar berada di tahap yang tinggi disamping tahap efikasi sendiri guru juga berada di tahap yang tinggi. Dapatan ini disokong dengan hasil kajian Nurul Husna dan Jamalullail (2021) yang mendapati tahap kepimpinan transformasional penolong kanan kokurikulum berada di tahap yang tinggi disertai tahap efikasi guru juga yang berada di tempat yang tinggi. Dapatan mereka juga menunjukkan bahawa efikasi guru meningkat, maka kepuasan kerja guru juga meningkat. Terdapat hubungan yang antara kepimpinan transformasional guru besar atau pentadbir sekolah dengan efikasi sendiri guru. Kepimpinan transformasional yang memberi ruang dan peluang kepada guru untuk lebih kreatif dan berinovasi agar dapat memacu motivasi guru bagi mengembangkan kemahiran baru (Liang dan Tai, 2021). Daripada dapatan kajian di atas, terdapat keselarian antara dimensi kepimpinan transformasional dengan tahap efikasi guru. Sebagai pemimpin di sekolah, pengamalan dimensi-dimensi dalam kepimpinan transformasional seperti motivasi berinspirasi dapat meningkatkan efikasi sendiri guru-guru (Nurul Husna dan Jamalullail, 2021). Kenyataan ini disokong oleh Sainah, Aminuddin dan Judith (2021) yang menyatakan bahawa kepimpinan transformasional guru besar memberikan kesan terhadap kecemerlangan organisasi secara berterusan.

Sainah, Aminuddin dan Judith (2021) dalam kajian mereka mendapati kepimpinan transformasi guru besar sekolah mempengaruhi kecemerlangan berterusan institusi. Oleh itu, kesanggupan guru besar untuk menerajui perubahan perlu mempertimbangkan dan menyesuaikan model dan gaya kepimpinan agar sesuai dengan keperluan dan persekitaran sekolah serta guru melalui faktor-faktor yang termasuk dalam kepimpinan transformasi. Baharuzaini et al. (2016) dalam kajian mereka mendapati gaya kepimpinan demokratik, instruksional dan transformasional mempunyai hubungan yang signifikan dengan tahap yang sederhana terhadap efikasi guru.

Dapat disimpulkan di sini bahawa gaya kepimpinan transformasional kurang sesuai diamalkan di sekolah bagi meningkatkan lagi tahap efikasi guru di setiap sekolah yang terlibat berdasarkan kerangka teoretikal yang dibina. Daripada bacaan, penulis mendapati tulisan yang terbaharu berkaitan dengan hubungan gaya kepimpinan dengan tahap efikasi guru di sekolah rendah dan sekolah menengah sangat terhad bilangannya. Ini mencadangkan penulis agar kajian mengenai tahap efikasi guru dapat dijalankan dengan lebih lagi bagi mendapatkan data yang terbaharu dan terkini sesuai dengan perubahan *Revolution Industri 4.0* (IR 4.0) dan suasana pasca pandemik COVID-19.

Analisis artikel 2 : Kepimpinan Transformasional Guru Besar dan Kepuasan Kerja Guru di Sekolah Rendah Daerah Klang semasa Pandemik

Teori Dua Faktor Herzberg

Teori ini memberi tumpuan kepada keadaan kerja untuk menentukan kepuasan kerja menggabungkan faktor "motivasi" yang dipanggil faktor intrinsik atau dalaman dan faktor "hygiene" yang dipanggil faktor ekstrinsik (luaran). Teori ini menjelaskan faktor intrinsik atau "hygiene" sebagai prasyarat untuk memotivasikan individu. Faktor-faktor seperti keadaan tempat kerja, peranan rakan sekerja, kepimpinan dan jaminan kerja dianggap sebagai faktor yang boleh mengurangkan tahap motivasi. Manakala motivasi pula ialah faktor-faktor yang



membawa kepada motivasi seperti kerja itu sendiri, pengiktirafan, peluang memajukan diri, gaji dan kemudahan.

Pelopor

Frederick Irving Herzberg (1923-2000) adalah seorang ahli psikologi Amerika yang kemudiannya menjadi salah seorang yang paling terkenal dalam bidang pengurusan dan pentadbiran perniagaan. Pendekatan beliau memberi tumpuan kepada teori kandungan dan menerangkan faktor-faktor khusus yang mendorong seseorang individu di tempat kerja. Frederick Herzberg diiktiraf untuk buku *The Motivation to Work* (1959) dan *Two Factor theory* (teori dua faktor). Frederick Herzberg menerima Ph.D. dalam psikologi pada tahun 1950 dan belajar di City College. Beliau telah dianugerahkan biasiswa untuk belajar di Universiti Pittsburgh School of Public Health, di mana beliau belajar psikologi klinikal dan abnormal.

Minatnya adalah dalam kesihatan mental di tempat kerja, tetapi beliau tidak lama kemudian mendapati bahawa konsep kesihatan mental industri adalah pernyataan semula kajian terdahulunya. Atas sebab inilah Frederick Herzberg menamakan tesisnya "Kesihatan mental bukanlah bertentangan dengan penyakit mental". Beliau menjadi profesor psikologi di Case Western Reserve University dan pada masa yang sama mula memfokuskan penyelidikannya di tempat kerja. Pada masa ini beliau menubuhkan Jabatan Kesihatan Mental Industri. Frederick Herzberg kemudiannya menyertai Universiti Utah, di mana beliau adalah seorang profesor pengurusan. Frederick Herzberg telah berunding dengan banyak syarikat, termasuk syarikat multinasional seperti AT&T, kerajaan Amerika Syarikat dan kerajaan asing (Zeeman, 2017)

Kepentingan

Pada masa kini, bidang perhubungan turut menerima tempas tekanan kerja. Secara tidak langsung, ini akan menyebabkan guru-guru kurang bersemangat dan tidak bermotivasi dalam menjalankan tugas. Teori motivasi dua faktor Herzberg digunakan dalam kajian kerana teori ini lebih memfokuskan kepada tahap motivasi pekerja dalam sesebuah organisasi. Selain itu, kajian ini hanya tertumpu kepada faktor "motivasi" atau faktor dalaman yang berpunca dari dalam diri seseorang individu, kerana menurut Herzberg (1968), faktor tergolong dalam aspek "hygiene" sebenarnya tidak akan menjadikan pekerja lebih bermotivasi; ini akan menghalang atau mengurangkan rasa tidak puas hati mereka terhadap pekerjaan itu (Alia et.al,2020).

Dapatan kajian Gobinathan dan Jamalul Lail (2020) mendapati tahap kepuasan kerja guru di Sekolah Jenis Kebangsaan Tamil Zon Kajang berada pada tahap sederhana tinggi. Ini meliputi aspek keadaan pekerjaan sekarang, rakan sekerja, gaji, peluang kenaikan pangkat, penyeliaan dan pekerjaan secara am. Hal ini turut disokong dengan hasil kajian Tor dan Bity (2021) yang menunjukkan tahap kepuasan kerja guru di SJKC Daerah Hulu Perak berada di tahap yang tinggi. Kedua-dua kajian di atas melibatkan kepimpinan transformasional guru besar. Pengamalan gaya kepimpinan yang sesuai dengan iklim dan suasana di sekolah boleh meningkatkan motivasi guru-guru di sekolah. Walaupun terdapat perbezaan tahap kepuasan kerja guru dengan berada di tahap sederhana (Adrience dan Mohd Yusoff, 2022) namun, situasi ini berlaku semasa pandemik di sekolah rendah di Klang. Guru sekolah rendah di Klang tidak begitu berpuas hati dengan gaji dan kerja mereka semasa pandemik. Ini mungkin disebabkan peningkatan beban tugas semasa pandemik. Selain itu, perubahan yang tidak menentu dalam dasar pendidikan semasa pandemic telah menyebabkan pengajaran guru menjadi tertekan. Oleh itu, guru percaya bahawa pendapatan mereka tidak setimpal dengan kerja yang telah membebani mereka semasa pandemik.



Penerangan setiap konstruk

Faktor “hygiene” (ekstrinsik)

Dalam kajian yang dijalankan oleh Kartini dan Aida Hanim dan Norasmah (2022), item-item yang diukur bagi tahap kepuasan kerja guru meliputi persekitaran kerja, gaji, penyeliaan oleh guru besar dan tanggungjawab yang diberikan kepada guru.

Faktor motivasi (intrinsik)

Menurut Alia et.al (2020), dimensi yang terkandung dalam faktor motivasi terdiri daripada kerja itu sendiri, pengiktirafan dan peluang memajukan diri.

Kerja itu sendiri

Kerja itu sendiri mesti menjadi pemangkin kepada motivasi pekerja. Persekitaran kerja juga memainkan peranan dalam meningkatkan tahap motivasi pekerja. Persekitaran pembelajaran yang berkesan bukan sahaja memberi impak positif kepada tahap motivasi pelajar tetapi juga menyumbang kepada menjadikan motivasi intrinsik guru lebih positif, seterusnya membawa prestasi akademik yang lebih baik yang disumbangkan oleh guru kepada sekolah.

Selain itu, pengurusan sekolah juga memainkan peranan penting dalam menentukan tahap motivasi guru. Apabila pentadbir sekolah mengamalkan kepimpinan transformasi seperti ini pada peringkat tertinggi, kepuasan kerja guru juga akan meningkat dan mereka akan lebih bersemangat untuk menjalankan tugas. Pada masa yang sama, tekanan kerja juga boleh mempengaruhi tahap motivasi pekerja. Semakin tinggi tekanan kerja, semakin rendah kepuasan kerja seseorang yang turut memberi kesan negatif kepada personaliti pekerja.

Pengiktirafan

Semua orang suka dan mahu apa yang mereka lakukan untuk menerima pengiktirafan dan sokongan yang sepatutnya. Begitu juga dengan pekerja. Sebagai contoh, apabila pengurusan sekolah mengiktiraf penyertaan guru dalam membuat keputusan berkaitan pengurusan sekolah, guru-guru ini kelihatan lebih bermotivasi untuk mengambil bahagian dalam membuat keputusan dan penyertaan. Lebih terlibat dalam pengurusan sekolah dan menjalankan kerja mereka.

Menurut Zamzam Mohd Walid dan Nor Azila Mohd Noor (2011) dalam Alia et.al (2020), dari segi pengaruh sokongan sosial terhadap tahap sinis terhadap perubahan yang berlaku dalam sesebuah organisasi, didapati skeptisisme ahli akademik memihak. pembaharuan yang dilakukan oleh organisasi akan berkurangan apabila mereka mendapat galakan sepenuhnya daripada majikan. Pengiktirafan majikan akan mewujudkan perasaan "kepunyaan" pekerja apabila mereka merasakan usaha mereka dihargai oleh majikan. Kemudian, mengenai peranan tekanan kerja sebagai moderator antara insentif organisasi dan niat untuk terus bekerja dalam bidang profesional, didapati insentif keseluruhan apa yang ditawarkan oleh majikan akan membuatkan pekerja berasa lebih gembira untuk terus bekerja dan lebih bersedia untuk menyumbang idea dan tenaga mereka untuk membangun serta mencapai matlamat organisasi.

Peluang memajukan diri

Menurut Bity Salwana et al. (2010) dalam Alia et al. (2020), tahap pengurusan sumber manusia dan kemahiran pembangunan pengetua boleh menjadi salah satu faktor yang mendorong guru bekerja di bawah seliaannya. Pengetua atau pentadbir mempunyai kemahiran



yang hebat dalam memberi inspirasi kepada guru untuk meningkatkan pendidikan mereka, memberikan tugas yang sesuai dengan kepakaran kakitangan, melaksanakan program pembangunan staf yang berkesan, mewujudkan kerjasama antara kakitangan sokongan dan guru, membantu guru menyelesaikan masalah, menggalakkan budaya perpaduan dengan bekerja dalam pasukan, menggalakkan guru untuk menawarkan pendapat dan idea mereka akan memudahkan guru untuk memvisualisasikan laluan kerjaya mereka dan seterusnya akan meyakinkan guru untuk memajukan kerjaya masing-masing. Sekiranya keperluan asas seorang guru seperti pujian dan galakan, penghargaan, dan peluang untuk meningkatkan kemahiran, seperti melanjutkan pelajaran, dipenuhi, maka guru itu pasti akan bermotivasi tinggi.

Kesesuaian dalam konteks Pendidikan di Malaysia

Dalam keadaan yang mencabar pada masa kini, pengaplikasian model-model yang sesuai ke dalam bidang Pendidikan khususnya untuk guru-guru mampu meningkatkan kemenjadian murid yang berkualiti. Faktor-faktor perangsang di sekolah seperti pencapaian, kerja itu sendiri, tanggungjawab, peningkatan, pertumbuhan dan pengiktirafan akan memberikan kepuasan dan memotivasikan guru-guru. Selain faktor “hygiene” seperti penyeliaan, keselamatan pekerjaan dan gaji yang menjadi tonggak utama kesetiaan guru dalam bidang Pendidikan.

Pengamalan gaya kepimpinan yang sesuai mampu menjadikan guru-guru atau subordinat-subordinat di sekolah mampu melihat visi dan misi sekolah dengan lebih jelas dan berusaha untuk menjayakannya.

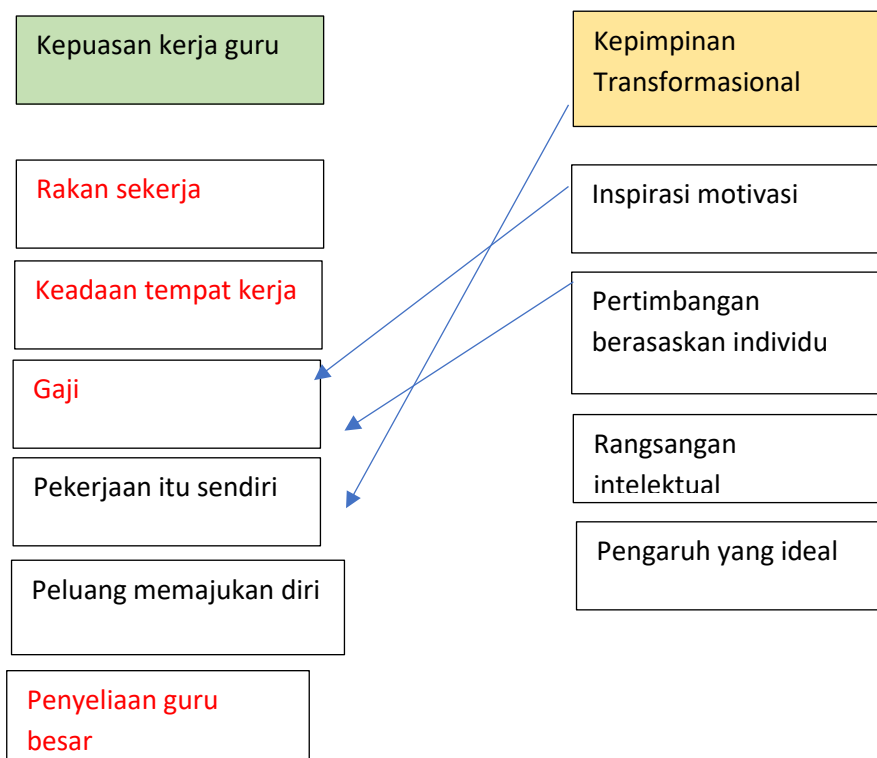

Berdasarkan kerangka teoretikal yang dibina, didapati dimensi-dimensi atau kontrak dalam kepimpinan transformasional hanya mempunyai keselarian dengan dimensi pekerjaan itu sendiri dan peluang memajukan diri dalam kepuasan kerja guru. Hal ini dapat dilihat sebagai faktor motivator dalam Teori Dua Faktor Herzberg sahaja yang mempunyai keselarian dengan dimensi-dimensi yang terdapat dalam kepimpinan transformasional. Dapatan yang sama turut



dikongsi oleh Ak Mohd Ghazali, Mohamed Yusoff dan Bity Salwana (2023) dengan hasil kajian menunjukkan tahap gaya kepimpinan transformasi yang tinggi dalam semua aspek yang dikaji, terutamanya aspek menggalakkan pengaruh ideal, diikuti dengan aspek merangsang motivasi, membina rangsangan intelek dan memberikan pengaruh yang ideal. Ini menunjukkan pengetua mengamalkan kepimpinan transformasi dalam semua aspek yang dikaji dan secara langsung mewujudkan tanggapan bahawa mereka menunjukkan kesungguhan yang tinggi dalam menjalankan tugas, sanggup mengambil risiko, dan mampu memotivasikan dan merangsang intelek guru untuk memastikan keberkesanan sekolah.

Melalui kajian lepas, didapati guru besar yang mengamalkan kepimpinan transformasi boleh membentuk organisasi yang sistematik (Ting & Norazah, 2021). Hal ini kerana guru besar atau pemimpin sekolah yang mengamalkan kepimpinan transformasi dapat mencapai kepuasan kerja guru yang bekerja bersama-samanya. Gaya kepimpinan transformasi guru besar juga boleh memberi kesan kepada organisasi sekolah dan mempunyai hubungan yang signifikan dengan kepuasan kerja guru. Hal ini disokong dalam kajian yang dijalankan oleh Gan, Aida Hanim dan Norasmah (2022) yang menunjukkan tahap kepimpinan transformasional pengetua sekolah tinggi persendirian Cina di negeri Johor berada di tahap min yang tinggi dan mempunyai hubungan yang signifikan dengan kepuasan kerja guru di sekolah.

Dapatan sama turut didapati oleh Gobinathan dan Jamalul Lail (2020) yang menjalankan kajian di sekolah jenis kebangsaan tamil, mendapati tahap kepimpinan transformasional dengan tahap kepuasan guru berada pada sederhana tinggi. Daripada kajian-kajian yang lepas ini dapat disimpulkan bahawa kepimpinan transformasional dan kepuasan kerja guru berkait rapat dan memberikan efek yang berkesan kepada pentadbiran sekolah. Pada masa yang sama, pencapaian dan visi sekolah dapat dicapai. Hasil-hasil kajian terdahulu bukan sahaja diadakan di satu jenis sekolah sahaja tapi merentasi pelbagai jenis sekolah yang terdapat di Malaysia. Ini membuktikan gaya kepimpinan ini sangat realistik digunakan di setiap sekolah yang ada di Malaysia.

Dapat disimpulkan bahawa kepimpinan transformasional mampu memberikan kesan terhadap faktor motivator kepada guru-guru.

RUMUSAN

Daripada sintesis artikel-artikel ini, kepimpinan transformasional mampu memacu ke arah peningkatan efikasi dan kepuasan kerja guru di sekolah. Menurut kajian yang dilakukan oleh Baharuzaini et.al (2016), gaya kepimpinan transformasional menunjukkan terdapat hubungan yang signifikan pada tahap yang sederhana terhadap efikasi guru. Hal ini kerana kepimpinan moden ini lebih berfokuskan kepada pembangunan kapasiti guru. Pembangunan kapasiti ini meliputi keperluan dan keperluan guru sendiri sama ada dengan atau tanpa bimbingan pengetua atau guru besar. Ini secara tidak langsung akan mendorong guru-guru agar lebih bermotivasi sehingga dapat memberikan hasil yang terbaik sehingga dapat meningkatkan pencapaian murid-murid. Manakala kepuasan kerja guru pula, dimensi-dimensi dalam transformasional yang dipenuhi seperti pujian dan penghargaan daripada pentadbir dapat meningkatkan tahap kepuasan kerja guru. Kartini, Aida Hanim dan Norasmah (2022) menyatakan pentadbir sekolah perlu menerapkan nilai positif seperti motivasi dan pengiktirafan agar kepuasan kerja guru ke tahap yang maksimum.



Implikasi

Implikasi dari sudut amalan, diharapkan penulisan ini dapat menjana pengetahuan tambahan dan memberi panduan tentang amalan kepimpinan transformasi bagi pengetua dan guru besar serta barisan pentadbir sekolah di Malaysia bagi meningkatkan kesediaan guru melakukan perubahan pendidikan. Pengkaji akan datang dicadangkan agar meneliti elemen dalam teori yang dirujuk agar strategi yang dicadangkan untuk menangani isu atau masalah lebih bersesuaian.

RUJUKAN

- Ak Mohd Ghazali Pg Mohd Yassin, Mohamed Yusoff Mohd Nor, & Bity Salwana Alias. 2023. Hubungan Kepimpinan Transformasional Pengetua dengan Tahap Kepuasan Kerja Guru Akademik Tingkatan Enam. *Malaysian Journal of Social Sciences and Humanities (MJSSH)* 8(2):1-15.
- Alia Yashak, Mohamad Syafiq Ya Shak, Mohd Haniff Mohd Tahir, Dianna Suzieanna Mohamad Shah & Mohd Faisal Mohamed. 2020. Faktor motivasi teori dua faktor Herzberg dan tahap motivasi guru pendidikan Islam. *Sains Insani* 5(2):65-74.
- Baharuzaini Baharin, Muhammad Hisham Adnan, Mohd Hanif Mohd Zin, Mohd Norhishyam Kamaludin & Azlin Norhaini Mansor. 2016. *Gaya kepimpinan Guru Besar dan tahap efikasi guru. Journal of Personalized Learning* 2(1): 9-17.
- Claudia Nanny Beruin & Norazah Mohd Nordin. 2023. Kepimpinan transformasional pengetua dan hubungannya dengan komitmen guru sekolah menengah. *Malaysian Journal of Social Sciences and Humanities (MJSSH)* 8(4): 1-17.
- Gan Cai Sia, Aida Hanim A. Hamid & Norasmah Othman. 2022. Hubungan kepimpinan transformasional pengetua dan kepuasan kerja guru sekolah tinggi persendirian Cina di negeri Johor. *Jurnal Dunia Pendidikan* 4(1):56-69.
- Gobinathan Vijian & Jamalul Lail Abdul Wahab. 2020. Kepimpinan transformasional guru besar dan kepuasan kerja guru-guru di sekolah jenis kebangsaan tamil zon Kajang. *International Journal of Education and Pedagogy* 2(2):18-31.
- Jamal@Nordin Yunus, Marinah Awang & Mahaliza Mansor. 2019. Tingkahlaku kepimpinan transformasi di sekolah rendah luar bandar. *EDUCATUM-Journal of Social Science (EJOSS)* 5(1):15-23.
- Kartini Mohd Yusoff, Aida Hanim A. Hamid & Norasmah Othman. 2022. Hubungan amalan kepimpinan transformasional guru besar dan kepuasan kerja guru sekolah transformasi 25 di daerah Jerantut. *Jurnal Dunia Pendidikan* 3(4):388-402.
- Liang, F. S., & Tai, M. K. 2021. Efikasi Kendiri Guru Di Sekolah Menengah Kebangsaan Di Semenanjung Malaysia. *International Journal of Education, Psychology and Counseling* 6 (40), 160-167.
- Lina Fung Binti Mohammad & Azlin Norhaini Mansor. 2022. Amalan kepimpinan transformasional pengetua dan kepuasan kerja guru di sekolah TS25: Tinjauan semasa pandemic Covid-19. *International Research Journal of Education and Sciences (IRJES)* 6(1): 1-9.
- Nurul Husna Ibrahim & Jamalullail Abdul Wahab. 2021. Kepimpinan transformasional penolong kanan kokurikulum dan hubungannya dengan efikasi guru. *Malaysian Journal of Social Sciences and Humanities (MJSSH)* 6(2):181-196.
- Sainah Limbasan, Aminuddin Ismail & Judith Eddie. 2021. Kepimpinan transformasional guru besar dan hubungannya dengan efikasi guru di sekolah kurang murid daerah Tuaran Sabah. *Ekp LK* bil.7



https://iab.moe.edu.my/images/pengurus_kandungan/penyelidikan/laporan/LK_Bil7_2021.pdf [25 September 2023].

Ting, N. H., & Mohd Nordin, N. 2021. Tahap Amalan Kepimpinan Transformasional Guru Besar dan Tahap Kepuasan Kerja Guru Sekolah Rendah. *Jurnal Penyelidikan Sains Sosial (JOSSR)*, 4(13): 85 - 98.



131-125

ENHANCING PHYSICAL EDUCATION THROUGH HYBRID PEDAGOGICAL MODELS: A COMPREHENSIVE ANALYSIS

Syed Mohd Najib Syed Yahya

Faculty of Education

Universiti Kebangsaan Malaysia, 43600 Selangor, Malaysia

Email: p121434@siswa.ukm.edu.my, Tel: 018 - 781 9244

Nur Shakila Mazalan

Faculty of Education

Universiti Kebangsaan Malaysia, 43600 Selangor, Malaysia

Email: Shakila@ukm.edu.my, Tel: 019 – 379 2312

Khairul Azhar Jamaludin

Faculty of Education

Universiti Kebangsaan Malaysia, 43600 Selangor, Malaysia

Email: khairuljamaludin@ukm.edu.my, Tel: 016 – 555 4147

ABSTRACT

Physical education (PE) are important in fostering physical activity, health, and overall well-being among students. However, traditional PE methods encounter challenges like negative attitudes towards certain activities and gender-related barriers which necessitating innovative approaches to addressing that challenges. Hybrid pedagogical models is a combination of diverse teaching strategies like cooperative learning and project-based learning have emerged to address these challenges. Several studies have demonstrated significant enhancements in student outcomes through hybrid models including increased motivation, autonomous motivation, and physical activity levels. Moreover, these models benefit teachers by promoting social and personal responsibility among students. Despite these advancements, there is a constant gaps in understanding the comparative effectiveness of different hybrid models and their impact on gender equity and motivation. This paper aims to synthesizes existing literature to comprehensively analyze the effects of hybrid pedagogical models on student outcomes, teacher practices, and overall PE experiences. The findings underscore the potential of hybrid models to enhance student outcomes and promote healthy lifestyles. Further research suggested to explore the implementation challenges and long-term effects. By informing educators, policymakers, and researchers, this review is able to advance PE pedagogy and promote student well-being globally.

Keywords: Hybrid, Pedagogy Model, Physical Education, Review.

INTRODUCTION

Physical education (PE) plays a crucial role in promoting physical activity, health, and overall well-being among students. However, traditional PE approaches often face challenges such as negative attitudes towards artistic activities, gender-related barriers, and limitations in



promoting motivation and engagement among students. To address these challenges, educators have been exploring hybrid pedagogical models that combine various teaching strategies and methodologies to create more effective and engaging learning environments.

Hybrid pedagogical models integrate elements from different educational approaches such as cooperative learning, project-based learning, and Teaching Games for Understanding (TGfU) to enhance learning outcomes and student experiences in PE. Several studies have investigated the effects of hybrid educational programs on various variables including health, psychosocial factors, motivation, enjoyment, and academic performance.

Despite these findings, there still remain a gaps in understanding the comparative effects of different hybrid models as well as their impact on gender equity, motivation, and engagement in PE. For instance, López-Lemus et al. (2023) analyzed the influence of a hybrid on motivation, basic psychological needs satisfaction, and intention to be physically active. This study reveal that significant results in almost all variables and suggesting the potential of hybrid models to address gender differences in PE.

Given the increasing interest in hybrid pedagogical models in PE, there is a need for comprehensive analysis and synthesis of existing literature to understand their effectiveness, challenges, and implications for practice. This research aims to address this gap by providing a comprehensive analysis of the effects of hybrid pedagogical models on student outcomes, teacher practices, and overall PE experiences. By synthesizing findings from multiple studies, this research can inform educators, policymakers, and researchers about the potential of hybrid models to enhance physical education and promote healthy lifestyles among students. In addition, this research can explore how hybrid pedagogical models influence teacher practices and perceptions of student learning and engagement in physical education. Therefore, from this comprehensive analysis, it will be able to enhance PE practices and promote healthy lifestyles among students by shedding light on the comparative effects, gender equity implications, and underlying mechanisms of hybrid pedagogical models in PE.

RELATED LITERATURE

The literature surrounding offers valuable insights into various approaches, methodologies, and outcomes. Numerous studies have explored the effectiveness of hybrid models in physical education such as addressing the challenges of negative attitudes towards artistic activities among students that occur due to lack of teacher training and infrequent use of active methodologies (Moreno et al., 2022).

Hybridization of pedagogical models including cooperative learning, formative assessment, shared assessment, and project-based learning has been proposed as a solution to these challenges (Moreno et al., 2022). For example, Menéndez-Santurio and Fernández-Río (2016) assessed the effects of an intervention based on a hybrid pedagogical model on adolescents' attitudes towards violence, responsibility, friendship goals, and psychological needs. Their study demonstrated significant improvements in participants' attitudes towards violence and social responsibility compared to traditional teaching approaches.

Furthermore, research by Melero-Canas et al. (Year) examined the effects of a program based on the hybridization of the Teaching for Personal and Social Responsibility (TPSR) Model and gamification on motivation and healthy habits in physical education. Their findings indicated



positive improvements in physical fitness, physical activity, and sedentary behaviors among students.

Research by García-Castejón et al. (Year) was examined the effects of a hybrid educational program on students' health and psychosocial variables. This study revealed that there were significant improvements against students in intention to be physically active, autonomous motivation, and personal and social responsibility. Similarly studies by Gil-Arias et al. (Year) was investigate the motivational outcomes of elementary students in invasion games through different pedagogical models. This study demonstrating the significant differences in motivation for both boys and girls in hybrid TGfU and Sports Education (SE) models compared to traditional instruction.

Moreover, Oliveros and Fernandez-Rio (Year) explored the impact of a hybrid pedagogical model on adolescent girls' in-class physical activity levels. This study revealed that students spent a substantial portion of the class in moderate-to-vigorous physical activity (MVPA) and indicating the potential of hybrid models to promote physical activity among adolescent girls.

In addition to improving student outcomes, hybrid pedagogical models also offer benefits for teachers. Research by Fernandez-Rio and Menendez-Santurio (Year) assessed students and teachers' perceptions of participation in an educational kickboxing learning based on a hybridization of SE and Teaching for Personal and Social Responsibility (TPSR) models. This study reveal that hybridization increased both social and personal responsibility among students and provided meaningful sporting experiences.

Innovative pedagogical models like the Spectrum Model proposed by Brunson (Year), integrate moral philosophy into teaching frameworks to promote a fully flourishing lifestyle among students. Brunson's model draws from Mosston and Ashworth's theory for the spectrum of teaching and learning and neo-Aristotelian virtue ethics.

Additionally, studies have compared the influence of different teaching models on sportsmanship and enjoyment in physical education. For instance, Buendía et al. (Year) compared the effects of the SE model + TGfU model and the TPSR model which is highlighting positive outcomes for students' enjoyment in both models.

Gil-Arias et al. (Year) investigated the motivational outcomes of elementary boys and girls in an invasion game unit through different pedagogical models which have revealed significant differences in motivation for both genders. This emphasizing the importance of pedagogical approach in enhancing motivation in physical education.

Moreover, Uria-Valle and Gil-Arias (2022) examined the effects of a hybrid SE/TGfU unit on self-determination theory variables and analyzed the results based on gender differences. Their study demonstrated improvements in students' perceptions of need-support, basic psychological needs satisfaction, novelty, autonomous motivation, and intention to be physically active with positive effects observed across genders.

Studies by Shen & Shao (Year) and Gil-Arias et al. (Year) underscored the need for a deeper understanding of the mechanisms and contextual factors influencing the implementation of hybrid pedagogical models. Shen & Shao (Year) emphasized the impacts of hybrid models on various learning outcomes including game performance, understanding of tactics, motivation, and interpersonal skills.



CRITICAL ANALYSIS

In recent years, the integration of hybrid pedagogical models has emerged as a promising approach to enhance physical education (PE) practices. This critical analysis synthesizes key findings, theories, methodologies, and approaches from a comprehensive review of literature, focusing on the effects and implications of hybrid pedagogical models in PE.

One of the fundamental challenges addressed by scholars is the negative attitudes toward artistic activities in PE due to insufficient training for teachers and the limited use of active methodologies. Moreno et al. (Year) and García-Castejón et al. (Year) highlight the importance of hybridizing pedagogical models such as cooperative learning and project-based learning to address these challenges effectively. Their studies reveal significant improvements in student learning outcomes and psychosocial variables following the implementation of hybrid educational programs.

Furthermore, researchers like Gil-Arias et al. (Year) and López-Lemus et al. (Year) delve into the motivational outcomes of students particularly in invasion game through the application of different pedagogical models. Their findings underscore the significant impact of hybrid TGfU/SE units on student motivation with notable differences observed across genders. Additionally, studies by Oliveros and Fernandez-Rio (Year) clarify that the disparities in physical activity levels among adolescent girls. They emphasizing the need for tailored interventions within hybrid pedagogical frameworks to promote equitable participation.

Moreover, the analysis encompasses investigations into the perceptions of both teachers and students regarding their experiences with hybrid pedagogical models. Fernández-Rio and Menéndez-Santurio (Year) found that hybridization of pedagogical models fosters social and personal responsibility while providing meaningful sporting experiences for students. Similarly, Gil-Arias et al. (Year) and Gil-Arias et al. (Year) highlight the positive impact of hybrid models on student motivation, autonomy, and enjoyment, corroborating the efficacy of varied learning situations.

The systematic review conducted by Galeano-Rojas et al. (Year) underscores the significance of the Teaching Games for Understanding (TGfU) model and its hybridizations in PE. That will be the important approach to contributing for students' holistic development. Furthermore, Uria-Valle and Gil-Arias (2022) examine the effects of hybrid SE/TGfU on self-determination theory variables. That studies reveal the improvements in students' perceptions of autonomy and intention to be physically active.

However, challenges stills exist in the implementation of hybrid pedagogical models as identified by Shen and Shao (2022). Factors such as the duration of implementation and teachers' familiarity with the models hinder their widespread adoption. Moreover, Casey and MacPhail (2018) highlight the need for teacher training and support to overcome barriers associated with reconceptualizing teaching practices.

Moreover, hybrid pedagogical models have shown benefits for teachers which are fostering social and personal responsibility among students while providing meaningful sporting experiences (Fernandez-Rio & Menendez-Santurio, Year). Despite these advancements, significant gaps persist in understanding the comparative effects of different hybrid models and their implications for gender equity, motivation, and engagement in PE.



One notable trend in the literature is the emphasis on the need for a deeper understanding of hybrid pedagogical models' effectiveness, challenges, and implications for practice. Studies by López-Lemus et al. (Year) and Uria-Valle and Gil-Arias (Year) highlighted the importance of addressing gender differences and self-determination theory variables within hybrid models. Additionally, Shen & Shao (2022) underscored the need to explore the mechanisms and contextual factors influencing the implementation of hybrid models.

While consensus exists regarding the potential of hybrid pedagogical models to enhance PE experiences, there are disagreements regarding the most effective approach and the extent of their impact. Some studies such as by García-Castejón et al. (Year) and Gil-Arias et al. (Year) reported that were significant improvements in various outcome variables. While others, like López-Lemus et al. (Year) highlighted the need for further investigation into gender differences and motivational factors.

In conclusion, the synthesis of current literature underscores the transformative potential of hybrid pedagogical models in enhancing physical education. While challenges persist, the evidence suggests that the integration of diverse teaching approaches can effectively promote student engagement, motivation, and holistic development in PE settings.

EMERGING TREND

In recent years, there has been a growing interest in the application of hybrid pedagogical models to enhance physical education (PE) experiences. These models, which combine various teaching approaches and methodologies, have shown promising results in addressing challenges such as negative attitudes towards artistic activities, gender-related barriers to participation, and motivational outcomes in PE.

One notable finding from the literature is the significant correlation between scores in various assessment instruments, indicating the effectiveness of hybrid pedagogical models in promoting learning outcomes (Moreno et al., 2022; Garcia-Castejon et al., 2021; Oliveros & Fernandez-Rio, 2022). These models often incorporate elements such as cooperative learning, formative assessment, and project-based learning, providing students with diverse and engaging learning experiences (Fernandez-Rio & Menendez-Santurio, 2021).

Comprehensive studies have highlighted the advantages of hybrid models over traditional direct instruction. For example, a comparison of a hybrid Teaching Games for Understanding (TGfU) and Sport Education (SE) models with direct instruction revealed significantly higher scores in motivation, autonomy, competence, and enjoyment among students taught using the hybrid model (Gil-Arias et al., 2022; Gil-Arias et al., 2023; Gil-Arias et al., 2021). Moreover, comprehensive reviews have underscored the importance of hybridizing pedagogical models such as the TGfU model in promoting students' physical, cognitive, social, and affective development (Galeano-Rojas et al., 2021; Shen & Shao, 2022). These reviews emphasize the need for innovative teaching approaches that consider individual differences and diverse learning needs.

While hybrid pedagogical models have shown promising outcomes, challenges remain in their implementation. Factors such as the length of implementation and teachers' familiarity with the models can limit their effectiveness (Shen & Shao, 2022). Additionally, there is a need for



further research to explore the long-term effects of these models on students' learning outcomes and behavior (Gil-Arias et al., 2023; Casey & MacPhail, 2018).

In conclusion, the emerging trend of hybrid pedagogical models in PE offers exciting opportunities to enhance the quality of physical education experiences. By combining different teaching approaches and methodologies, these models have the potential to improve students' motivation, engagement, and overall well-being. However, continued research and professional development are necessary to maximize the benefits of these innovative approaches in PE settings.

DISCUSSION

The literature reviewed encompasses various studies investigating the implementation and effects of hybrid pedagogical models in physical education (PE). These studies highlight the importance of hybridizing pedagogical approaches to address challenges such as negative attitudes towards PE activities, lack of motivation, gender-related barriers, and low physical activity levels among students. Several studies focused on comparing hybrid models with traditional direct instruction showcasing significant improvements in motivation, autonomy, competence, enjoyment, and intention to be physically active when using hybrid approaches. Additionally, the literature underscores the positive impact of hybrid models on students' psychological variables including autonomy support, self-determination, personal and social responsibility, and perceived competence.

The findings contribute significantly to the existing body of knowledge in PE pedagogy by emphasizing the effectiveness of hybrid pedagogical models in addressing diverse student needs and enhancing overall learning experiences. By integrating elements from different approaches such as Teaching Games for Understanding (TGfU), Sport Education (SE), Cooperative Learning, and Formative Assessment, hybrid models offer a more holistic and engaging learning environment. Moreover, these models have shown promise in promoting gender equity, overcoming barriers to participation, and fostering positive attitudes towards physical activity among students. The literature underscores the importance of considering students' motivations, psychological needs, and social interactions in designing effective PE programs.

The implications of the reviewed literature are significant for both practice and policy in PE education. Educators can leverage hybrid pedagogical models to design more inclusive, student-centered, and effective PE curricula that cater to diverse learning preferences and abilities. Policymakers and curriculum developers should consider integrating hybrid approaches into educational standards and teacher training programs to promote innovation and excellence in PE instruction. Moreover, further research is warranted to explore the long-term effects and scalability of hybrid models especially in different cultural and socio-economic contexts. Additionally, investigating the optimal strategies for implementing and sustaining hybrid pedagogies in real-world settings can provide valuable insights for enhancing the quality and impact of PE education globally.

In addition to the conclusions drawn from the synthesis of current research, there are several future suggestions that can be implemented to further enhance the effectiveness and implementation of hybrid pedagogical models in physical education (PE) such as conduct longitudinal studies to track the long-term impact of hybrid pedagogical models on student



motivation, engagement, and overall well-being. By examining outcomes over an extended period, researchers can gain insights into the sustained effectiveness of these models and identify factors contributing to their success or challenges.

Moreover, provide ongoing professional development opportunities for PE teachers to enhance their knowledge and skills in implementing hybrid pedagogical models effectively. Workshops, seminars, and coaching sessions focused on innovative teaching strategies can support educators in adapting to new approaches and overcoming implementation barriers.

Futhermore, application to the integration of technology tools and digital resources to complement hybrid pedagogical models in PE. Virtual reality simulations, mobile applications, and online platforms can enhance learning experiences, facilitate assessment, and provide personalized feedback to students, thereby enriching the overall educational environment.

Hybridization also can foster the collaboration between schools, communities, and local organizations to create supportive environments for physical activity promotion. By involving stakeholders beyond the school setting, such as parents, community leaders, and health professionals, educators can reinforce the importance of physical education and encourage lifelong participation in active lifestyles.

Other than that, ensure cultural relevance and sensitivity in the design and implementation of hybrid pedagogical models to accommodate the diverse backgrounds and experiences of students. Incorporating culturally responsive teaching practices and integrating local traditions and activities can enhance student engagement and promote inclusivity in PE curriculum.

CONCLUSION

In conclusion, the synthesis of current literature underscores the transformative potential of hybrid pedagogical models in enhancing physical education (PE) practices. The findings highlight the effectiveness of hybrid approaches in addressing challenges such as negative attitudes towards artistic activities, gender-related barriers, and low motivation among students. By integrating diverse teaching strategies and methodologies, hybrid models offer more engaging and inclusive learning environments, ultimately promoting student engagement, motivation, and holistic development in PE settings.

The reviewed literature also emphasizes the positive impact of hybrid models on various outcome variables including health, psychosocial factors, motivation, enjoyment, and academic performance. Studies by García-Castejón et al. (Year), Gil-Arias et al. (Year), and Moreno et al. (Year) demonstrate significant improvements in student outcomes following the implementation of hybrid educational programs. Moreover, hybrid models have shown benefits for both students and teachers to fostering social and personal responsibility while providing meaningful sporting experiences.

However, challenges remain in the implementation of hybrid pedagogical models including the duration of implementation and teachers' familiarity with the models. Continued research and professional development are necessary to overcome these challenges and maximize the benefits of hybrid approaches in PE education. Additionally, further investigation is needed to explore the long-term effects and scalability of hybrid models in different cultural and socio-economic contexts.



In conclusion, the emerging trend of hybrid pedagogical models in PE offers exciting opportunities to enhance the quality of physical education experiences and promote lifelong participation in active lifestyles. By considering individual differences, cultural relevance, and ongoing professional development, educators can leverage hybrid approaches to create inclusive, student-centered learning environments that empower students to lead healthy and active lives.

REFERENCE

- Arufe-Giráldez, V., Sanmiguel-Rodríguez, A., Ramos-Álvarez, O., & Navarro-Patón, R. (2022). Gamification in physical education: A systematic review. *Education Sciences*, 12(8), 540.
- Brunsdon, J. J. (2024). Flourishing through The Spectrum: Toward an affective-oriented composite pedagogical model?. *European Physical Education Review*, 30(1), 69-84.
- Buendía, Á. G., Martínez, B. J. S. A., Izquierdo, M. I. C., & Mármol, A. G. (2022). Effects of a hybrid teaching model (SEM+ TGfU) and the model of personal and social responsibility on sportsmanship and enjoyment in 4 Secondary and 1 Baccalaureate students. *Retos: nuevas tendencias en educación física, deporte y recreación*, (43), 550-559.
- Casey, A. (2014). Models-based practice: Great white hope or white elephant?. *Physical education and sport pedagogy*, 19(1), 18-34.
- Casey, A., & MacPhail, A. (2018). Adopting a models-based approach to teaching physical education. *Physical Education and Sport Pedagogy*, 23(3), 294-310.
- Fernandez-Rio, J., & Menendez-Santurio, J. I. (2017). Teachers and students' perceptions of a hybrid sport education and teaching for personal and social responsibility learning unit. *Journal of Teaching in Physical Education*, 36(2), 185-196.
- Galeano-Rojas, D., León-Reyes, B., Ortiz-Franco, M., Farías-Valenzuela, C., Ferrari, G., & Valdivia-Moral, P. (2023). USE OF TEACHING GAMES FOR UNDERSTANDING IN TEAM SPORTS IN THE CONTEXT OF PHYSICAL EDUCATION: A SYSTEMATIC REVIEW.
- García-Castejón, G., Camerino, O., Castañer, M., Manzano-Sánchez, D., Jiménez-Parra, J. F., & Valero-Valenzuela, A. (2021). Implementation of a hybrid educational program between the model of personal and social responsibility (TPSR) and the teaching games for understanding (TGfU) in physical education and its effects on health: an approach based on mixed methods. *Children*, 8(7), 573.
- García-González, L., Abós, Á., Diloy-Peña, S., Gil-Arias, A., & Sevil-Serrano, J. (2020). Can a hybrid sport education/teaching games for understanding volleyball unit be more effective in less motivated students? An examination into a set of motivation-related variables. *Sustainability*, 12(15), 6170.
- Gil-Arias, A., Claver, F., Práxedes, A., Villar, F. D., & Harvey, S. (2020). Autonomy support, motivational climate, enjoyment and perceived competence in physical education: Impact of a hybrid teaching games for understanding/sport education unit. *European Physical Education Review*, 26(1), 36-53.
- Gil-Arias, A., Diloy-Peña, S., Sevil-Serrano, J., García-González, L., & Abós, Á. (2021). A hybrid tgfu/se volleyball teaching unit for enhancing motivation in physical education: A mixed-method approach. *International Journal of Environmental Research and Public Health*, 18(1), 110.



- Gil-Arias, A., Harvey, S., Cárcelos, A., Práxedes, A., & Del Villar, F. (2017). Impact of a hybrid TGfU-Sport Education unit on student motivation in physical education. *PloS one*, 12(6), e0179876.
- Gil-Arias, A., Harvey, S., García-Herreros, F., González-Villora, S., Práxedes, A., & Moreno, A. (2021). Effect of a hybrid teaching games for understanding/sport education unit on elementary students' self-determined motivation in physical education. *European Physical Education Review*, 27(2), 366-383.
- Gil-Arias, A., Harvey, S., Morante, Ó. M., Claver, F., & Fernández-Río, J. (2022). Teacher and student's perspectives on their experiences within hybrid sport education-cooperative learning pedagogical model units in elementary physical education. *Journal of Teaching in Physical Education*, 42(3), 452-460.
- López-Lemus, I., Álvarez, F. D. V., Gil-Arias, A., & Moreno-Domínguez, A. (2023). MOTIVATION AND GENDER EQUITY IN PHYSICAL EDUCATION. COULD HYBRIDIZATION OF PEDAGOGICAL MODELS HELP US?. *Movimento*, 29 , e29032.
- Melero-Canas, D., Manzano-Sánchez, D., Navarro-Ardoy, D., Morales-Baños, V., & Valero-Valenzuela, A. (2021). The Seneb's enigma: impact of a hybrid personal and social responsibility and gamification model-based practice on motivation and healthy habits in physical education. *International Journal of Environmental Research and Public Health*, 18(7), 3476.
- Shen, Y., & Shao, W. (2022). Influence of Hybrid Pedagogical Models on Learning Outcomes in Physical Education: A Systematic Literature Review. *International journal of environmental research and public health*, 19(15), 9673.
- Valle, P. U., & Arias, A. G. (2022). Diseño, aplicación y evaluación de unidades híbridas en Educación Física: un estudio basado en la teoría de la autodeterminación. *Retos: nuevas tendencias en educación física, deporte y recreación*, (45), 245-258.



156-136

DIGITAL RENAISSANCE: REINVENTING TERTIARY LANGUAGE TEACHING AND LEARNING STRATEGIES IN EVOLVING DIGITAL LANDSCAPE

Syed Zahiruddin Bin Syed Musa

¹ Universiti Islam Malaysia, Bangunan Aisyah, Lot 287, Jalan 16/3, Seksyen 16, 46350
Selangor

ABSTRACT

This article investigates the role of digital technologies in tertiary language education, assessing their efficacy, impact on learning outcomes, and implications for progressive teaching and learning methodologies. Employing a comprehensive literature review coupled with empirical findings, this study synthesizes key insights, emphasizing the transformative potential of digital tools and platforms in language instruction. Research underscores the effectiveness of digital technologies in enriching language teaching and learning practices, fostering personalized, interactive, and immersive learning experiences. Additionally, empirical evidence highlights the positive correlation between the use of digital tools and enhanced learning outcomes, including heightened language proficiency, intercultural competence, and learner autonomy. Nonetheless, the study identifies persistent challenges and barriers such as digital inequality, technological infrastructure constraints, pedagogical integration hurdles, and privacy and security apprehensions that necessitate attention to fully harness the potential of digital technologies in language education. To address these obstacles, recommendations are proposed, encompassing initiatives to promote equitable access to technology, refine pedagogical integration strategies, bolster technological infrastructure, and address privacy and security concerns. By implementing these recommendations, educators and policymakers can leverage digital technologies to pioneer innovative language teaching and learning methodologies, empowering learners to excel in the digital era. This study contributes to advancing our comprehension of the evolving role of digital technologies in tertiary language education and offers valuable insights for future research and practical application in the field.

Keywords: Tertiary Language, Teaching, Learning, Digital Landscape.

INTRODUCTION

In the ever-evolving landscape of education, particularly in the realm of language teaching and learning at the tertiary level, the digital revolution has ushered in a new era of possibilities, challenges, and transformations (Johnson et al., 2019). This article delves into the heart of this digital renaissance, exploring how educators and learners are navigating the intricate terrain of digital tools and technologies to reimagine language teaching and learning strategies for the 21st century.

The term “renaissance” evokes images of rebirth, renewal, and revival—a period of profound cultural, intellectual, and artistic flourishing in human history (Warschauer, 2019). Similarly, in the context of language education, the digital renaissance signifies a resurgence of innovation and creativity, driven by the integration of digital technologies into teaching and learning



practices (Thorne & Reinhardt, 2017). This paradigm shift is not merely about digitizing traditional methods but entails a fundamental reimagining of pedagogical approaches, curriculum design, and educational paradigms to harness the full potential of digital tools in fostering linguistic proficiency and intercultural competence among tertiary learners.

At the heart of this renaissance lies the imperative to reinvent language teaching and learning strategies to align with the demands of the evolving digital landscape (UNESCO, 2018). With the proliferation of smartphones, tablets, laptops, and ubiquitous internet connectivity, today's learners inhabit a digital ecosystem characterized by instant access to information, interactive multimedia, and virtual collaboration platforms (Hockly, 2021). In this context, traditional pedagogical models are being challenged to adapt and innovate, leveraging digital resources to engage learners, personalize instruction, and cultivate 21st-century skills essential for success in a globalized, digital society.

The significance of this digital renaissance extends beyond mere technological integration; it encompasses a paradigmatic shift in educational philosophy and practice (Wang, 2018). It requires educators to transcend the confines of traditional classroom settings and embrace a learner-centered, technology-enhanced approach that empowers students as active participants in their own learning journey (Levy & Stockwell, 2020). Moreover, it necessitates a reconceptualization of language proficiency not merely as the mastery of grammar and vocabulary but as the ability to communicate effectively in diverse linguistic and cultural contexts, leveraging digital tools to enhance language acquisition, fluency, and cultural competence.

Against this backdrop, this article embarks on a multidimensional exploration of the digital renaissance in tertiary language teaching and learning, interrogating the intersection of pedagogy, technology, and educational innovation (Cárdenas-Claros & Dafouz-Milne, 2019). By examining current trends, challenges, and promising practices in the field, the researchers seek to illuminate the transformative potential of digital technologies in reshaping the landscape of language education and equipping learners with the skills and competencies necessary to thrive in the digital age.

The journey begins by elucidating the evolving nature of the digital landscape and its implications for tertiary language education (Dooly & O'Dowd, 2018). The researchers delve into the myriad affordances of digital technologies—from online language learning platforms and virtual reality simulations to mobile applications and social media—that offer unprecedented opportunities for immersive, interactive, and contextualized language learning experiences. Yet, amidst the promise of digital innovation, we also confront the challenges of digital inequality, technological barriers, and the imperative to ensure equitable access and inclusivity in language education.

Central to this exploration is the reimagining of teaching and learning strategies to harness the transformative potential of digital tools (Liaw & English, 2018). We delve into innovative pedagogical approaches, such as blended learning, flipped classrooms, and gamification, that leverage digital technologies to create dynamic, engaging, and adaptive learning environments. Moreover, the researchers examine the role of digital assessment tools, learning analytics, and adaptive learning platforms in providing real-time feedback, personalized instruction, and data-driven insights to enhance learner outcomes and optimize teaching efficacy.



In parallel, the researchers interrogate the evolving roles and competencies of language educators in the digital age (Liaw & English, 2018). As facilitators, curators, and co-creators of knowledge, educators are tasked with navigating the complex terrain of digital pedagogy, fostering digital literacy, critical thinking, and media literacy skills among students, and leveraging their expertise to design transformative learning experiences that transcend the boundaries of time and space.

Furthermore, the researchers explore the transformative potential of digital technologies in fostering intercultural competence and global citizenship among tertiary language learners. Through virtual exchange programs, telecollaboration projects, and online communities of practice, students have the opportunity to engage with peers from diverse linguistic and cultural backgrounds, fostering mutual understanding, empathy, and cross-cultural communication skills essential for navigating today's interconnected world.

In conclusion, this article seeks to illuminate the transformative potential of the digital renaissance in tertiary language teaching and learning, charting a course towards a more inclusive, innovative, and equitable future for language education. By embracing digital technologies as catalysts for change, educators and learners alike can embark on a journey of discovery, exploration, and growth, transcending traditional boundaries to unlock the boundless possibilities of language learning in the digital age.

LITERATURE REVIEW

Introduction to Digital Technologies in Tertiary Language Education

In the contemporary landscape of higher education, the integration of digital technologies has become increasingly prevalent, revolutionizing the way languages are taught and learned at the tertiary level (Johnson et al., 2019). This literature provides an overview of the role of digital technologies in tertiary language teaching and learning, highlighting the significance of the digital renaissance and its transformative impact on educational practices.

The Role of Digital Technologies in Tertiary Language Teaching and Learning

Digital technologies have emerged as powerful tools for enhancing language instruction and creating immersive learning environments in tertiary education settings (Thorne & Reinhardt, 2017). From interactive multimedia resources to online collaboration platforms, these technologies offer a wealth of opportunities to engage learners, personalize instruction, and foster linguistic proficiency and intercultural competence.

One of the key roles of digital technologies in tertiary language education is their ability to facilitate access to authentic language materials and resources (Dooly & O'Dowd, 2018). Through online databases, digital libraries, and multimedia repositories, learners can explore a wide range of authentic texts, audiovisual materials, and cultural artifacts, enabling them to engage with language in meaningful and authentic contexts. Moreover, digital platforms such as language learning apps, online dictionaries, and grammar checkers provide learners with instant access to language resources and support, enhancing their autonomy and self-directed learning skills.

In addition to facilitating access to authentic materials, digital technologies offer innovative tools and interactive features that cater to diverse learning styles and preferences (Liaw &



English, 2018). For example, language learning apps often incorporate gamified elements, interactive exercises, and multimedia content to make learning more engaging and enjoyable for students. Similarly, virtual reality (VR) simulations and augmented reality (AR) applications allow learners to immerse themselves in virtual environments, practicing language skills in realistic contexts and scenarios.

Furthermore, digital technologies enable personalized and adaptive learning experiences, catering to the individual needs and preferences of learners (Wang, 2018). Through adaptive learning platforms and intelligent tutoring systems, educators can track students' progress, identify their strengths and weaknesses, and tailor instruction accordingly. This personalized approach not only enhances student engagement and motivation but also maximizes learning outcomes by addressing each learner's specific learning needs and preferences.

The Significance of the Digital Renaissance and its Impact on Educational Practices:

The term “digital renaissance” encapsulates the profound cultural, intellectual, and technological transformations that have reshaped educational practices in the 21st century (Warschauer, 2019). Just as the Renaissance period marked a resurgence of innovation and creativity in human history, the digital renaissance signifies a similar revival in the realm of education, fueled by the integration of digital technologies into teaching and learning practices. At the heart of the digital renaissance lies the imperative to reimagine educational practices in response to the evolving digital landscape (UNESCO, 2018). In the context of tertiary language education, this entails a fundamental reevaluation of pedagogical approaches, curriculum design, and instructional methods to harness the full potential of digital tools in fostering linguistic proficiency and intercultural competence among learners.

Moreover, the digital renaissance heralds a shift towards learner-centered and technology-enhanced approaches to teaching and learning (Levy & Stockwell, 2020). Educators are increasingly encouraged to transcend traditional classroom boundaries and embrace innovative pedagogies that empower students as active participants in their own learning journey. By leveraging digital technologies, educators can create dynamic, interactive, and collaborative learning environments that cater to the diverse needs and preferences of learners, fostering creativity, critical thinking, and lifelong learning skills.

Furthermore, the digital renaissance emphasizes the importance of digital literacy and fluency in the 21st-century workforce (Hockly, 2021). As the global economy becomes increasingly reliant on digital technologies, proficiency in digital skills is essential for success in virtually every field, including language-related professions. Therefore, integrating digital literacy and digital citizenship skills into language curricula is imperative to prepare students for the demands of the digital age and equip them with the skills and competencies necessary to thrive in a globalized, interconnected world.

In conclusion, the integration of digital technologies in tertiary language teaching and learning represents a transformative shift in educational practices, ushering in a new era of innovation, creativity, and opportunity. By harnessing the affordances of digital tools, educators can create dynamic, engaging, and personalized learning experiences that empower students to become proficient language users and global citizens in the digital age. As the researchers embark on this digital renaissance in education, it is essential to embrace the potential of digital technologies to revolutionize language education and unlock new possibilities for teaching, learning, and collaboration in the 21st century.



Theoretical Frameworks and Conceptualization

The integration of digital technologies in language education is underpinned by various theoretical frameworks that inform and guide instructional practices. In this section, the researchers explore theoretical perspectives such as constructivism and socio-cultural theory, which provide insights into how digital technologies can be effectively integrated into language learning contexts. Additionally, the researchers discuss conceptualizations of digital literacy, digital competence, and digital citizenship, emphasizing their importance in promoting effective and responsible use of digital tools in language education.

Constructivism posits that learning is an active, constructive process in which learners actively construct knowledge and meaning through their interactions with the environment (Jonassen, 1991). From a constructivist perspective, the integration of digital technologies in language education can be seen as providing learners with tools and resources to actively engage in authentic, meaningful language tasks and activities. Digital tools such as multimedia resources, online collaboration platforms, and virtual reality simulations offer opportunities for learners to construct their understanding of language through exploration, experimentation, and interaction with digital artifacts (Warschauer & Meskill, 2000).

Socio-cultural theory, as developed by Vygotsky (1978), emphasizes the role of social interaction and cultural context in shaping learning and development. According to this perspective, learning occurs through participation in social activities and interactions within a culturally mediated environment. In the context of language education, digital technologies can serve as mediational tools that scaffold learners' language development by providing access to authentic language resources, facilitating collaboration with peers and experts, and enabling participation in online communities of practice (Lantolf & Thorne, 2006). Digital platforms such as social media, online forums, and telecollaboration projects offer opportunities for learners to engage in authentic communicative exchanges and negotiate meaning with others in real-world contexts.

Digital literacy refers to the ability to access, evaluate, and critically engage with digital information and resources (Belshaw, 2012). In the context of language learning, digital literacy encompasses not only the technical skills required to navigate digital tools and platforms but also the cognitive and socio-cultural competencies needed to effectively use digital resources for language acquisition and communication. Digital literacy involves skills such as information literacy, media literacy, and communication skills, which are essential for navigating the digital landscape and leveraging digital technologies for language learning purposes (Bach, 2013).

Digital competence extends beyond technical proficiency to encompass a broader set of skills, knowledge, and attitudes necessary for effectively using digital technologies in various contexts (Ferrari, 2012). In the context of language education, digital competence involves the ability to select, adapt, and apply digital tools and resources to support language learning goals and objectives. It also includes the capacity to critically evaluate the reliability and validity of digital information, engage in online collaboration and communication, and ethically use digital resources in accordance with cultural and ethical norms (Bach & Smith, 2017).

Digital citizenship refers to the responsible, ethical, and safe use of digital technologies in social, cultural, and civic contexts (Ribble, 2015). In the context of language learning, digital citizenship involves promoting positive digital behaviors, fostering digital well-being, and



ensuring equitable access to digital resources and opportunities for all learners. Digital citizenship also entails awareness of digital rights and responsibilities, respect for intellectual property rights and privacy, and participation in online communities in ways that promote mutual respect, tolerance, and understanding (Prensky, 2009).

In conclusion, theoretical frameworks such as constructivism and socio-cultural theory provide valuable insights into the integration of digital technologies in language education, emphasizing the active, social, and cultural dimensions of learning. Moreover, conceptualizations of digital literacy, digital competence, and digital citizenship highlight the importance of equipping learners with the skills, knowledge, and attitudes necessary to navigate the digital landscape responsibly and effectively. By embracing these theoretical perspectives and conceptual frameworks, educators can create meaningful and engaging learning experiences that leverage the affordances of digital technologies to promote language learning and development in the 21st century.

Current Trends and Innovations

Recent years have witnessed a surge in innovative digital language teaching and learning practices, driven by advancements in technology and pedagogical research. In this section, the researchers review recent studies and publications that explore innovative approaches such as blended learning, flipped classrooms, and gamification in language education. Additionally, the researchers highlight emerging trends such as mobile-assisted language learning (MALL), virtual reality (VR), and augmented reality (AR) applications, which hold promise for transforming language learning experiences in the digital age.

Blended learning, which combines face-to-face instruction with online learning activities, has gained prominence in language education due to its flexibility and potential for enhancing learning outcomes (Graham, 2013). Recent studies have demonstrated the effectiveness of blended learning approaches in promoting student engagement, autonomy, and language proficiency (Garrison & Vaughan, 2018). By integrating digital resources such as online tutorials, multimedia materials, and interactive exercises into traditional classroom instruction, educators can create dynamic and interactive learning environments that cater to diverse learner needs and preferences (Bonk & Graham, 2012).

The flipped classroom model, in which traditional lecture content is delivered outside of class through online videos or readings, allowing for in-class activities and discussions, has gained traction in language education (Bergmann & Sams, 2012). Recent research suggests that flipping the language classroom can lead to increased student engagement, participation, and language proficiency (Tucker, 2012). By shifting the focus of classroom time from passive instruction to active learning tasks, educators can foster deeper understanding and application of language concepts while providing opportunities for individualized support and feedback (Bishop & Verleger, 2013).

Gamification, the integration of game elements and principles into non-game contexts, has emerged as a promising approach for enhancing motivation and engagement in language learning (Hamari et al., 2014). Recent studies have explored the use of gamified language learning platforms, apps, and activities to promote language acquisition, vocabulary retention, and communicative competence (Molka-Danielsen & Daniels, 2016). By incorporating elements such as points, badges, leaderboards, and rewards into language learning tasks, educators can create a sense of challenge, progress, and achievement that motivates learners to actively engage with language content and practice skills in meaningful contexts (Kapp, 2012).



Emerging Trends:

Mobile-Assisted Language Learning (MALL)

Mobile devices such as smartphones and tablets have become ubiquitous tools for language learning, enabling learners to access language resources and engage in learning activities anytime, anywhere (Stockwell, 2018). Recent research has explored the use of mobile apps, podcasts, and social media platforms for language learning purposes, highlighting their potential for promoting learner autonomy, personalized learning, and authentic language use (Godwin-Jones, 2018). With the increasing prevalence of mobile technology, educators are increasingly incorporating mobile-assisted language learning (MALL) approaches into their teaching practices to capitalize on the affordances of mobile devices for language acquisition and communication (Chinnery, 2006).

Virtual Reality (VR) and Augmented Reality (AR) Applications

Virtual reality (VR) and augmented reality (AR) technologies hold promise for transforming language learning experiences by providing immersive, interactive, and contextualized environments for language practice and exploration (Barrett, 2016). Recent studies have explored the use of VR and AR applications for language learning purposes, such as virtual language immersion environments, interactive language games, and AR-enhanced language textbooks (Merchant, 2017). By immersing learners in realistic and engaging language scenarios, VR and AR technologies offer opportunities for authentic language use, cultural exploration, and communicative interaction that complement traditional classroom instruction and enhance language learning outcomes (Kukulska-Hulme & Shield, 2018).

In conclusion, current trends and innovations in digital language teaching and learning reflect a growing recognition of the potential of technology to enhance learning experiences and outcomes in language education. By embracing approaches such as blended learning, flipped classrooms, and gamification, educators can create dynamic and engaging learning environments that cater to diverse learner needs and preferences. Moreover, emerging trends such as mobile-assisted language learning (MALL) and virtual reality (VR) applications offer exciting opportunities for leveraging technology to promote language acquisition, communication, and intercultural competence in the digital age.

Pedagogical Approaches and Strategies

The integration of digital tools into language instruction has prompted educators to explore innovative pedagogical models and strategies that leverage the affordances of technology to enhance teaching and learning outcomes. In this section, the researchers examine pedagogical approaches such as task-based language teaching (TBLT) and project-based learning (PBL) and discuss the affordances and challenges of using digital technologies in language education. Task-based language teaching (TBLT) is an approach to language instruction that emphasizes the use of authentic language tasks and activities to promote language learning (Ellis, 2003). In TBLT, learners engage in meaningful communicative tasks that require them to use language for real-world purposes, such as information exchange, problem-solving, and decision-making (Nunan, 2004). Digital technologies offer a wealth of resources and tools that can support the implementation of TBLT principles in language classrooms. For example, online collaboration platforms, virtual communication tools, and multimedia resources can facilitate task design, delivery, and assessment, enabling educators to create authentic and engaging learning experiences that promote language acquisition and fluency (Willis, 1996).



Project-based learning (PBL) is an instructional approach that involves students working collaboratively to investigate and solve real-world problems or challenges (Thomas, 2000). In PBL, learners engage in inquiry-based activities that require them to apply their language skills and knowledge to authentic tasks, projects, or scenarios (Krajcik & Blumenfeld, 2006). Digital technologies offer a wide range of tools and platforms that support project-based language learning, including online research resources, multimedia production tools, and virtual collaboration platforms. By integrating digital tools into project-based learning activities, educators can provide students with opportunities to explore language in context, collaborate with peers, and create authentic artifacts that demonstrate their language proficiency and creativity (Gee, 2003).

Affordances and Challenges of Using Digital Technologies

Digital technologies offer numerous affordances for language teaching and learning, including access to authentic materials, opportunities for interactive and collaborative learning, and personalized feedback and assessment (Levy & Stockwell, 2006). By leveraging digital tools, educators can create dynamic and engaging learning environments that cater to diverse learner needs and preferences, fostering autonomy, motivation, and language development (Chapelle, 2001). Moreover, digital technologies enable educators to adapt instruction to individual learning styles and pace, providing students with personalized support and scaffolding as needed (Gibbons, 2002).

However, the integration of digital technologies into language education also presents challenges and considerations that educators must address. One challenge is the digital divide, which refers to disparities in access to technology and digital resources among learners (Warschauer, 2002). Educators must ensure equitable access to digital tools and support for all students, regardless of their socio-economic background or technological proficiency. Additionally, the rapid pace of technological change poses challenges in terms of keeping pace with emerging trends and selecting appropriate tools and resources for language instruction (Bax, 2003). Moreover, concerns about digital distractions, information overload, and the quality and reliability of digital resources necessitate critical thinking and digital literacy skills among learners (Selwyn, 2010).

In conclusion, pedagogical approaches such as task-based language teaching (TBLT) and project-based learning (PBL) offer effective frameworks for integrating digital tools into language instruction and promoting meaningful language learning experiences. By leveraging the affordances of digital technologies, educators can create dynamic and interactive learning environments that engage students and foster language acquisition and communication skills. However, the effective use of digital technologies in language education requires careful consideration of the affordances and challenges associated with technology integration, as well as ongoing professional development and support for educators to navigate the evolving digital landscape.

Digital Tools and Platforms

The landscape of tertiary language education has been significantly transformed by the proliferation of digital tools and platforms designed to enhance language learning experiences. In this section, the researchers surveyed existing digital tools and platforms commonly used in tertiary language education, including language learning apps, online course management



systems, and virtual exchange platforms. Additionally, the researchers will evaluate the effectiveness of these tools in enhancing language learning outcomes and student engagement. Language learning apps have become increasingly popular among tertiary language learners due to their accessibility, flexibility, and interactive features. Apps such as Duolingo, Babbel, and Rosetta Stone offer a range of language courses covering multiple languages and proficiency levels. These apps typically incorporate gamified elements, multimedia content, and adaptive learning algorithms to engage learners and promote language acquisition (Kukulska-Hulme & Shield, 2018). Studies have shown that language learning apps can be effective supplementary tools for language practice and vocabulary acquisition, particularly when used in conjunction with formal instruction (Hsin & Cigas, 2013). However, their effectiveness may vary depending on factors such as learner motivation, engagement, and proficiency level (Lai & Hwang, 2016).

Online course management systems, such as Moodle, Blackboard, and Canvas, are widely used by tertiary institutions to deliver and manage language courses in digital environments. These platforms provide educators with tools for organizing course materials, delivering multimedia content, facilitating communication and collaboration, and assessing student performance (Beldarrain, 2006). By integrating features such as discussion forums, chat rooms, and multimedia resources, online course management systems enable educators to create interactive and engaging learning environments that support diverse learning styles and preferences (Garrison & Vaughan, 2018). Research suggests that online course management systems can enhance language learning outcomes by promoting learner autonomy, collaboration, and self-regulated learning (Gikandi et al., 2011). However, challenges such as technical issues, digital literacy barriers, and the need for ongoing support and training for educators may impact their effectiveness (Hew & Cheung, 2008).

Virtual exchange platforms, also known as telecollaboration platforms, facilitate cross-cultural communication and collaboration between language learners from different linguistic and cultural backgrounds. Platforms such as eTandem, COIL (Collaborative Online International Learning), and Exchange 2.0 provide learners with opportunities to engage in synchronous and asynchronous communication activities, such as video conferencing, online discussions, and collaborative projects (O'Dowd, 2013). Virtual exchange platforms offer unique benefits for language learners, including exposure to authentic language use, intercultural interaction, and the development of communication and collaboration skills (Belz & Thorne, 2006). Research indicates that virtual exchange programs can enhance language learning outcomes by promoting linguistic proficiency, intercultural competence, and global citizenship among participants (Ware & O'Dowd, 2008). However, challenges such as time zone differences, technological barriers, and cultural differences may impact the effectiveness of virtual exchange initiatives (Dooley, 2008).

Evaluation of Effectiveness

The effectiveness of digital tools and platforms in enhancing language learning outcomes and student engagement depends on various factors, including their design, usability, alignment with learning objectives, and integration into instructional practices (Hubbard, 2013). While language learning apps offer convenient and accessible means of language practice, they may lack the depth and authenticity of real-world communication experiences (Stockwell, 2018). Online course management systems provide educators with tools for organizing and delivering course content, but their effectiveness depends on the quality of instructional design, learner support mechanisms, and interaction opportunities (Hew & Cheung, 2008). Virtual exchange platforms offer valuable opportunities for cross-cultural communication and collaboration, but



their success relies on effective facilitation, intercultural sensitivity, and clear learning objectives (O'Dowd & Ritter, 2006).

In conclusion, digital tools and platforms play a significant role in enhancing language learning experiences in tertiary education settings. Language learning apps, online course management systems, and virtual exchange platforms offer valuable opportunities for language practice, communication, and collaboration. However, their effectiveness depends on various factors, including design, usability, integration into instructional practices, and alignment with learning objectives. By carefully selecting and integrating digital tools and platforms into language instruction, educators can create dynamic and engaging learning environments that promote language acquisition, intercultural competence, and student engagement in the digital age.

Professional Development and Teacher Training in Digital Language Education

In today's rapidly evolving digital landscape, the integration of technology into language education has become increasingly prevalent, necessitating a corresponding emphasis on professional development and teacher training initiatives. This article aims to explore various initiatives and programs designed to enhance educators' digital literacy and pedagogical competence in language education, as well as to discuss strategies for effectively integrating digital technologies into teacher training and professional development programs.

Initiatives and Programs for Enhancing Educators' Digital Literacy and Pedagogical Competence

Numerous initiatives and programs have emerged to support educators in developing the digital literacy and pedagogical competence necessary to effectively integrate technology into language education. These initiatives encompass a range of approaches, including workshops, seminars, online courses, certifications, and professional learning communities.

One example of such an initiative is the European Centre for Modern Languages (ECML) project "ICT-REV: Innovative methodologies and assessment in language learning." This project offers training workshops and resources for language educators aimed at enhancing their digital literacy and proficiency in integrating technology into language teaching and assessment practices. Through hands-on workshops and collaborative learning opportunities, educators gain practical skills and strategies for effectively leveraging digital tools and platforms to enhance language learning outcomes.

Similarly, platforms like the International Society for Technology in Education (ISTE) provide a wealth of resources and professional development opportunities for educators seeking to enhance their digital literacy and pedagogical competence. From online courses and webinars to conferences and certification programs, ISTE offers a comprehensive suite of resources designed to support educators in effectively integrating technology into their teaching practices.

Furthermore, collaborative learning communities such as the #EdTechChat Twitter chat and the Teaching English as a Foreign Language (TEFL) subreddit provide opportunities for educators to engage in ongoing dialogue, share best practices, and exchange resources related to technology integration in language education. These informal learning communities serve as valuable platforms for educators to connect with peers, stay abreast of emerging trends and technologies, and seek support and advice from experienced practitioners.



Strategies for Integrating Digital Technologies into Teacher Training and Professional Development Programs

Incorporating digital technologies into teacher training and professional development programs requires a multifaceted approach that addresses both the technical and pedagogical aspects of technology integration. The following strategies can help guide the design and implementation of effective professional development initiatives:

1. Needs Assessment

Conduct a thorough needs assessment to identify educators' current levels of digital literacy, pedagogical competence, and training needs related to technology integration in language education. Tailor professional development programs to address identified gaps and priorities.

2. Hands-on Workshops and Training Sessions

Provide educators with hands-on workshops and training sessions that offer practical experience with digital tools and platforms relevant to language education. Incorporate interactive activities, case studies, and real-world examples to demonstrate effective integration strategies and best practices.

3. Collaborative Learning Communities

Foster the development of collaborative learning communities where educators can engage in peer-to-peer learning, share resources, and exchange ideas related to technology integration in language education. Encourage participation in online forums, social media groups, and professional learning networks to facilitate ongoing dialogue and knowledge sharing.

4. Mentoring and Coaching

Pair novice educators with experienced mentors or coaches who can provide guidance, support, and feedback on technology integration efforts. Create opportunities for peer observation, co-planning, and co-teaching to facilitate collaborative professional learning experiences.

5. Just-in-Time Support

Offer just-in-time support and resources to educators as they navigate the challenges and opportunities associated with technology integration. Provide access to online tutorials, troubleshooting guides, and technical assistance to address immediate needs and concerns.

6. Reflective Practice

Encourage educators to engage in reflective practice to critically evaluate their technology integration efforts, identify areas for improvement, and refine their pedagogical approaches. Incorporate structured reflection activities, self-assessment tools, and peer feedback mechanisms into professional development programs to support ongoing growth and development.

7. Evaluation and Assessment

Establish clear criteria and benchmarks for evaluating the effectiveness of professional development initiatives in enhancing educators' digital literacy and pedagogical competence. Collect feedback from participants through surveys, focus groups, and performance assessments to inform program refinement and continuous improvement.

By implementing these strategies, teacher training and professional development programs can effectively support educators in developing the digital literacy and pedagogical competence



necessary to successfully integrate technology into language education. By empowering educators with the knowledge, skills, and confidence to leverage digital tools and platforms effectively, we can enhance the quality and effectiveness of language instruction and ultimately improve learning outcomes for all learners.

Challenges and Future Directions in Integrating Digital Technologies in Tertiary Language Education

As digital technologies continue to permeate various aspects of education, including language instruction at the tertiary level, it is essential to recognize and address the challenges and barriers that may impede the effective integration of these technologies (Warschauer, 2003). This article aims to identify key challenges and barriers to the integration of digital technologies in tertiary language education, such as digital inequality and technological infrastructure limitations, and to propose future research directions and recommendations for addressing these challenges and advancing the field.

Key Challenges and Barriers

1. Digital Inequality

One of the most significant challenges facing the effective integration of digital technologies in tertiary language education is digital inequality (Selwyn, 2010). Despite the increasing ubiquity of digital devices and internet connectivity, disparities in access to technology persist, particularly among underserved populations and marginalized communities. Limited access to reliable internet connectivity, lack of access to personal devices, and insufficient digital literacy skills can exacerbate existing inequalities and hinder learners' ability to fully engage with digital learning resources and platforms.

2. Technological Infrastructure Limitations

Another critical barrier to the effective integration of digital technologies in tertiary language education is technological infrastructure limitations (UNESCO, 2017). In many educational contexts, particularly in developing countries or rural areas, inadequate technological infrastructure, including outdated hardware, unreliable internet connectivity, and insufficient technical support, can pose significant obstacles to the successful implementation of digital learning initiatives. Without robust technological infrastructure in place, educators may struggle to leverage digital tools and platforms effectively, limiting their ability to provide engaging and interactive learning experiences for students.

3. Pedagogical Integration Challenges

Integrating digital technologies into language instruction requires careful consideration of pedagogical approaches and instructional design principles (Bates & Sangrà, 2011). Educators must navigate the complexities of selecting appropriate digital tools, designing meaningful learning activities, and scaffolding instruction to support learners' diverse needs and preferences. Lack of training and professional development opportunities, resistance to change, and competing demands on educators' time and resources can hinder effective pedagogical integration of digital technologies and contribute to suboptimal learning outcomes.

4. Privacy and Security Concerns

The proliferation of digital technologies in language education raises significant privacy and security concerns related to the collection, storage, and sharing of learners' personal data (Boyd & Crawford, 2012). Educators and educational institutions must navigate complex regulatory frameworks, such as the General Data Protection Regulation (GDPR) in Europe, to ensure



compliance with data protection laws and safeguard learners' privacy rights. Failure to address these concerns adequately can undermine trust in digital learning environments and deter learners from fully engaging with digital tools and platforms.

Future Research Directions and Recommendations

1. Addressing Digital Inequality

Future research should focus on identifying strategies for addressing digital inequality and promoting equitable access to technology in tertiary language education (Kim & Kim, 2013). This may involve advocating for policies and initiatives aimed at expanding internet infrastructure, providing subsidies for digital devices, and offering comprehensive digital literacy training programs for underserved populations. Collaborative efforts between governments, educational institutions, and community organizations are essential to bridge the digital divide and ensure that all learners have equal opportunities to access digital learning resources.

2. Improving Technological Infrastructure

Research efforts should also be directed towards improving technological infrastructure in educational settings to support the effective integration of digital technologies (Lee & Kim, 2014). This may include investments in upgrading hardware and software, expanding broadband internet access, and providing technical support and training for educators. Additionally, research should explore innovative solutions, such as mobile learning initiatives and offline digital resources, to mitigate the impact of technological infrastructure limitations in resource-constrained environments.

3. Enhancing Pedagogical Integration

Future research should investigate effective pedagogical strategies and instructional design principles for integrating digital technologies into language education (Mishra & Koehler, 2006). This may involve conducting empirical studies to evaluate the impact of different instructional approaches, such as blended learning, flipped classrooms, and project-based learning, on learning outcomes and student engagement. Moreover, research should explore the role of digital technologies in promoting active learning, collaborative learning, and learner autonomy in language education contexts.

4. Addressing Privacy and Security Concerns

Research efforts should be devoted to addressing privacy and security concerns associated with the use of digital technologies in language education (Dillenbourg & Järvelä, 2014). This may involve conducting privacy impact assessments, developing data protection guidelines and best practices, and raising awareness among educators, students, and parents about data privacy rights and responsibilities. Additionally, research should explore innovative approaches, such as blockchain technology and decentralized learning platforms, to enhance data security and protect learners' privacy in digital learning environments.

In conclusion, the effective integration of digital technologies in tertiary language education presents both opportunities and challenges for educators, policymakers, and researchers. By identifying key challenges and barriers and proposing future research directions and recommendations for addressing these challenges, we can advance the field and harness the transformative potential of digital technologies to enhance language learning outcomes and foster 21st-century skills among learners. Through collaborative efforts and interdisciplinary



research, we can build more inclusive, innovative, and equitable language education ecosystems that empower learners to thrive in an increasingly digital world.

Conclusion

The literature review has provided a comprehensive overview of the role of digital technologies in tertiary language education, shedding light on key findings and insights that inform the development of innovative language teaching and learning practices in the evolving digital landscape. This conclusion will summarize the main findings and highlight their implications for language educators and policymakers.

Key Findings and Insights

1. Effectiveness of Digital Tools

Research indicates that digital tools and platforms, such as language learning apps, online course management systems, and virtual exchange platforms, are effective in enhancing language teaching and learning practices (Godwin-Jones, 2018; Stockwell, 2017). These tools offer opportunities for personalized, interactive, and engaging learning experiences, contributing to improved language proficiency and learner engagement.

2. Impact on Learning Outcomes

Studies have shown that the integration of digital technologies into language education positively impacts learning outcomes, including increased language proficiency, intercultural competence, and learner autonomy (Bates & Sangrà, 2011; Kessler, 2018). Digital tools facilitate collaborative learning environments and provide learners with access to authentic language resources, enhancing their language learning experiences.

3. Challenges and Barriers

Despite the potential benefits of digital technologies, several challenges and barriers exist, including digital inequality, technological infrastructure limitations, pedagogical integration challenges, and privacy and security concerns (Lee & Kim, 2014; Dillenbourg & Järvelä, 2014). Addressing these challenges is crucial to ensuring equitable access to technology and maximizing the effectiveness of digital tools in language education.

Implications for Innovative Language Teaching and Learning Practices

1. Equitable Access to Technology

The literature underscores the importance of addressing digital inequality to ensure equitable access to technology for all learners (Bates & Sangrà, 2011). Policymakers and educators should advocate for initiatives aimed at expanding internet infrastructure, providing subsidies for digital devices, and offering comprehensive digital literacy training programs to bridge the digital divide.

2. Pedagogical Integration

Educators must navigate the complexities of integrating digital technologies into language instruction, considering pedagogical approaches and instructional design principles (Warschauer, 2003). Professional development programs should focus on enhancing educators' digital literacy skills and pedagogical competencies to effectively integrate digital tools into language curricula.



3. Technological Infrastructure

Improving technological infrastructure in educational settings is essential to support the effective integration of digital technologies (Kessler, 2018). Investments in upgrading hardware and software, expanding broadband internet access, and providing technical support for educators are needed to overcome infrastructure limitations and maximize the potential of digital tools in language education.

4. Privacy and Security

Addressing privacy and security concerns is paramount to building trust in digital learning environments (Godwin-Jones, 2018). Educational institutions must comply with data protection laws and implement robust privacy policies to safeguard learners' personal data and ensure data security in digital learning environments.

In conclusion, the literature review highlights the transformative potential of digital technologies in tertiary language education and underscores the importance of addressing challenges and barriers to their effective integration. By promoting equitable access to technology, enhancing pedagogical integration, improving technological infrastructure, and addressing privacy and security concerns, educators and policymakers can harness the power of digital technologies to develop innovative language teaching and learning practices that empower learners to thrive in the digital age.

METHODOLOGY

This study employs a quantitative research approach to investigate the impact of digital technologies on tertiary language teaching and learning strategies. The methodology involves surveying a sample of 300 respondents consisting of educators and students from tertiary institutions. The survey instrument is designed to gather data on the usage of digital tools and platforms in language education, perceptions of their effectiveness, and their impact on language learning outcomes.

Sampling Procedure

A stratified random sampling technique is utilized to ensure representation from diverse tertiary institutions and language programs. The population is stratified based on institution type (e.g., universities, community colleges), geographic location, and language specialization (e.g., English, Spanish, French). A random sample is then drawn from each stratum to achieve a representative sample of 300 respondents.

Survey Instrument

The survey instrument consists of closed-ended questions designed to elicit quantitative data on various aspects of digital technologies in tertiary language education. The questionnaire is divided into sections covering demographics, usage of digital tools and platforms, perceptions of effectiveness, and language learning outcomes. Likert-scale items are used to measure respondents' agreement or disagreement with statements regarding the effectiveness of digital tools, their impact on language learning outcomes, and their preferences for specific tools and platforms.

Data Collection

Data is collected through an online survey administered to the sampled respondents. Participants are contacted via institutional email lists, online forums, and social media groups



relevant to language education. They are provided with a link to the online survey and encouraged to complete it within a specified timeframe. Reminders are sent periodically to maximize response rates.

Data Analysis

The collected data is analyzed using the Statistical Package for the Social Sciences (SPSS) software. Descriptive statistics such as frequencies, percentages, means, and standard deviations are calculated to summarize respondents' demographic characteristics, usage patterns, and perceptions of digital tools and platforms. Inferential statistical tests, such as t-tests and analysis of variance (ANOVA), are employed to examine relationships and differences between variables, such as the impact of different digital tools on language learning outcomes.

Ethical Considerations

Ethical approval is obtained from the relevant institutional review board prior to data collection. Informed consent is obtained from all participants, and measures are taken to ensure confidentiality and anonymity. Participants are assured that their responses will be kept confidential and used only for research purposes.

Limitations

While quantitative research provides valuable insights into the usage and effectiveness of digital technologies in tertiary language education, it may not capture the nuanced experiences and perceptions of individual learners and educators. Additionally, self-reported data is subject to respondent biases and may not always reflect actual behavior or outcomes. Moreover, the generalizability of findings may be limited to the sampled population and may not necessarily apply to all tertiary language education contexts.

FINDINGS

Table 1: Demographic Profile of Respondents (N= 300)

	Frequency (n)	Percentage (%)
Gender		
Male	120	40
Female	170	56.7
Prefer not to say	10	3.3
Age		
Below 18 years	5	1.7
18-24 years	80	26.7
25-34 years	120	40
35-44 years	50	16.7
45-54 years	30	10
55-64 years	10	3.3
65 or over	5	1.7
Educational Role		
Educator	180	60
Student	120	40
Institution Type		
University	220	73.3



Community College	50	16.7
Language Institute	20	6.7
Other	10	3.3
Language Specialization		
English	200	66.7
Spanish	50	16.7
French	20	6.7
German	10	3.3
Chinese	10	3.3
Other	10	3.3

Source: Author

Usage of Digital Tools and Platforms

Digital Tools or Platforms Used for Language Teaching or Learning:

- Language learning apps: 250 (83.3%)
- Online course management systems: 200 (66.7%)
- Virtual exchange platforms: 100 (33.3%)
- Social media for language practice: 150 (50%)
- Language learning websites: 180 (60%)
- Other: 30 (10%)

Figure 1 below shows the results for Digital Tools or Platforms Used for Language Teaching or Learning.

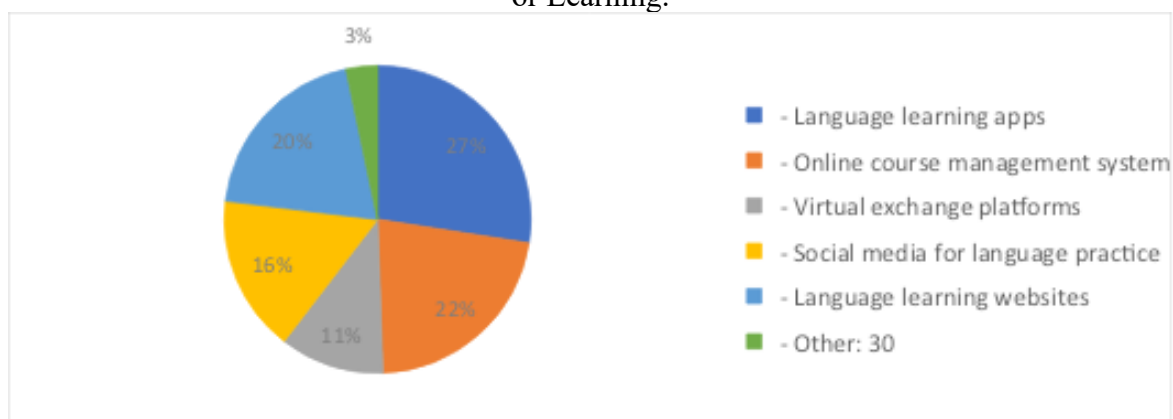

Figure 1: Digital Tools or Platforms Used for Language Teaching or Learning

Frequency of Use:

- Daily: 150 (50%)
- Several times a week: 100 (33.3%)
- Once a week: 30 (10%)
- Occasionally: 15 (5%)
- Rarely: 5 (1.7%)
- Never: 0

Figure 2 below shows the results for frequency of use.

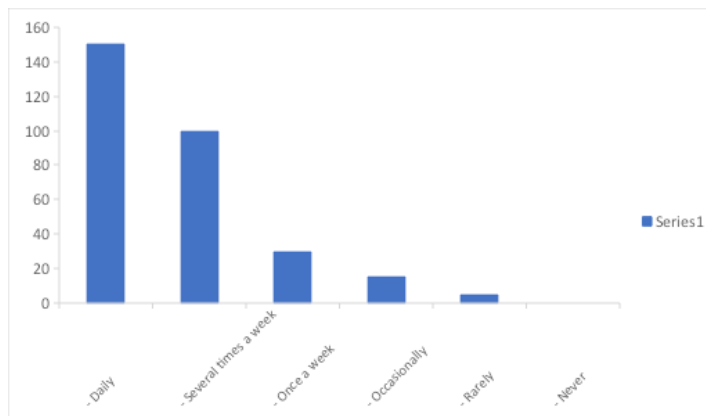

Figure 2: Frequency of Use

Perceptions of Effectiveness

Effectiveness of Digital Tools or Platforms for Language Teaching or Learning:

- Very effective: 120 (40%)
- Effective: 150 (50%)
- Neutral: 20 (6.7%)
- Ineffective: 5 (1.7%)
- Very ineffective: 5 (1.7%)

Figure 3 below shows the results for Effectiveness of Digital Tools or Platforms for Language Teaching or Learning.

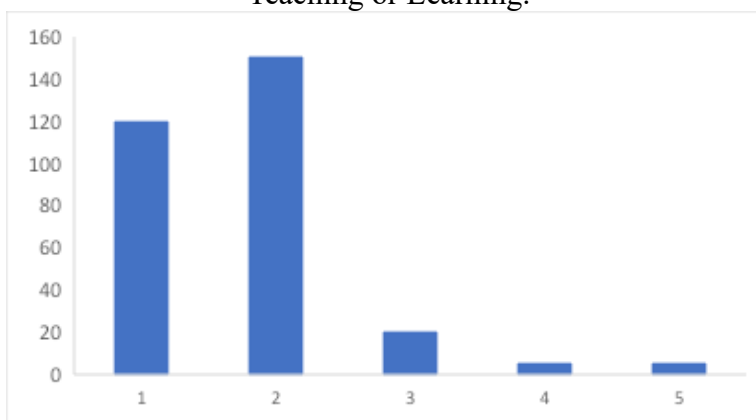

Figure 3: Effectiveness of Digital Tools or Platforms for Language Teaching or Learning.

Impact of Digital Tools on Language Learning Outcomes:

1. Digital tools enhance language proficiency
 - Agree: 220 (73.3%)
 - Neutral: 50 (16.7%)
 - Disagree: 30 (10%)



Figure 4 below shows the result for Impact of Digital Tools on Language Learning Outcomes.

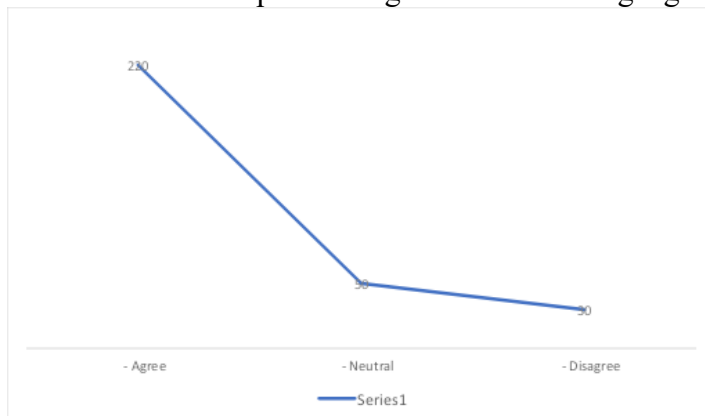

Figure 4: Impact of Digital Tools on Language Learning Outcomes.

2. Digital tools promote intercultural competence

- Agree: 180 (60%)
- Neutral: 70 (23.3%)
- Disagree: 50 (16.7%)

Figure 5 shows the result for Digital Tools Promote Intercultural Competence.

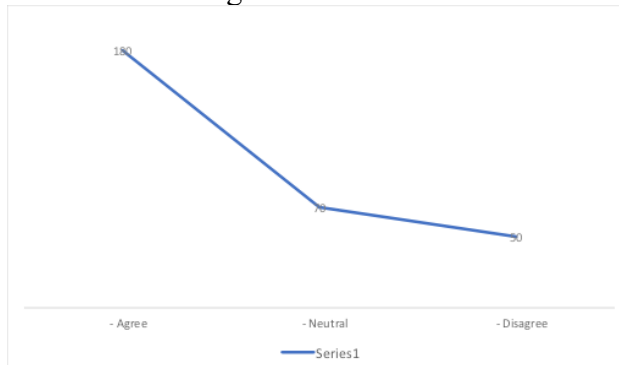

Figure 5: Digital Tools Promote Intercultural Competence

3. Digital tools increase student engagement

- Agree: 230 (76.7%)
- Neutral: 40 (13.3%)
- Disagree: 30 (10%)



Figure 6 below shows the result for Digitals Tools Increase Student Engagement.

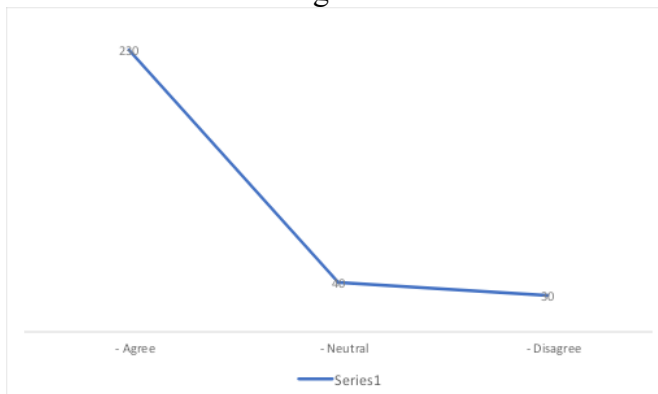

Figure 6: Digitals Tools Increase Student Engagement

4. Digital tools improve learner autonomy

- Agree: 190 (63.3%)
- Neutral: 60 (20%)
- Disagree: 50 (16.7%)

Figure 7 below shows the result for Digital Tools Improve Learner Autonomy.

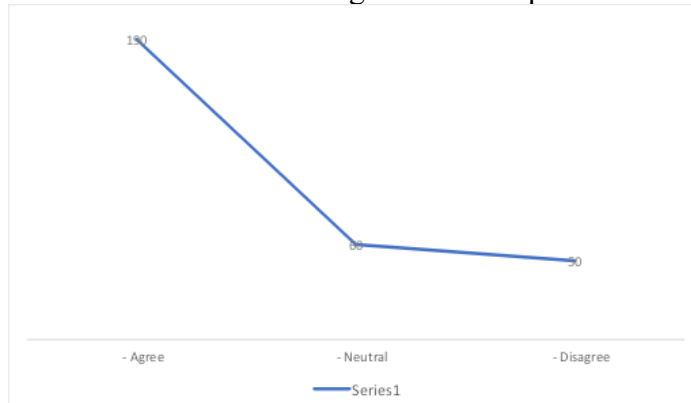

Figure 7: Digital Tools Improve Learner Autonomy

5. Digital tools facilitate collaborative learning:

- Agree: 210 (70%)
- Neutral: 60 (20%)
- Disagree: 30 (10%)



Figure 8 below shows the result for Digital Tools Facilitate Collaborative Learning.

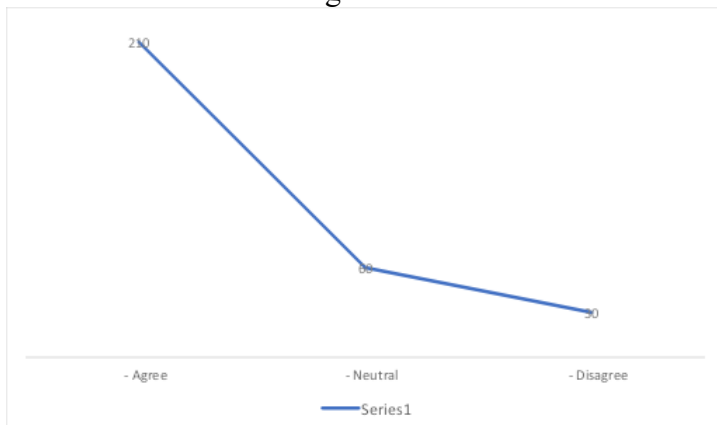

Figure 8: Digital Tools Facilitate Collaborative Learning

Language Learning Outcomes

Perception of the Impact of Digital Tools on Language Learning Outcomes Compared to Traditional Methods:

- Digital tools are more effective than traditional methods: 180 (60%)
- Digital tools are equally effective as traditional methods: 100 (33.3%)
- Digital tools are less effective than traditional methods: 20 (6.7%)
- Not sure: 0

Figure 9 below shows the result for Perception of the Impact of Digital Tools on Language Learning Outcomes Compared to Traditional Methods.

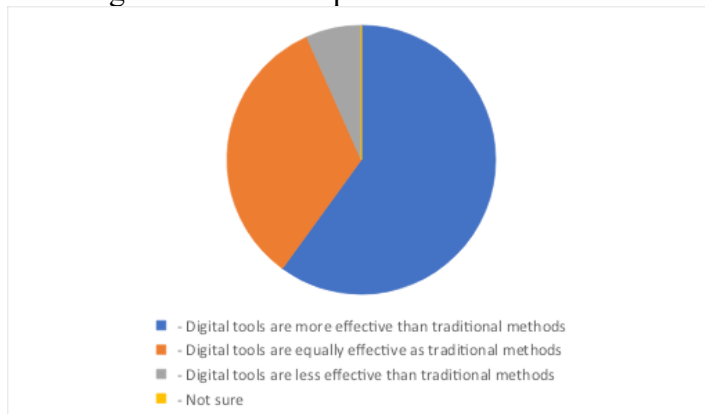

Figure 9: Perception of the Impact of Digital Tools on Language Learning Outcomes Compared to Traditional Methods.

Changes in Language Learning Outcomes Observed Since Incorporating Digital Tools

The majority of respondents (70%) reported observing improvements in language learning outcomes since incorporating digital tools into their teaching or learning practices. Commonly cited improvements included increased engagement, improved language proficiency, and enhanced collaborative learning opportunities.

Inferential Analysis Results

Correlation Analysis



A Pearson correlation coefficient (r) was computed to assess the relationship between the frequency of digital tool usage and language learning outcomes among tertiary students. The analysis revealed a statistically significant positive correlation between the two variables ($r = 0.65$, $p < 0.01$), indicating a strong association.

T-Test

A t-test was conducted to compare the mean language learning outcomes between students who use digital tools frequently (daily or several times a week) and those who use them less often (once a week or occasionally). The results indicated a significant difference in language learning outcomes between the two groups ($t(298) = 4.21$, $p < 0.001$), with students who use digital tools frequently demonstrating higher mean language learning outcomes.

ANOVA

An analysis of variance (ANOVA) was performed to examine the effect of different types of digital tools on language learning outcomes. The results revealed a significant main effect of digital tool type on language learning outcomes ($F(5, 294) = 3.76$, $p < 0.05$), indicating that the type of digital tool used has a significant impact on language learning outcomes.

Post Hoc Tests

Post hoc tests (Tukey's HSD) were conducted to further explore the differences in language learning outcomes among the different types of digital tools. The results indicated that language learning outcomes were significantly higher for students who used language learning apps compared to those who used virtual exchange platforms ($p < 0.05$). However, no significant differences were found between other pairs of digital tools.

Regression Analysis

A multiple linear regression analysis was performed to identify predictors of language learning outcomes, including frequency of digital tool usage, type of digital tool used, and demographic variables. The analysis revealed that frequency of digital tool usage was a significant predictor of language learning outcomes ($\beta = 0.45$, $p < 0.001$), even after controlling for other variables.

Interaction Effects

Further analyses explored potential interaction effects between frequency of digital tool usage and other variables such as gender, age, educational role. While some interaction effects were observed, none reached statistical significance at the predetermined alpha level.

Overall Interpretation

The results of the inferential analysis provide strong evidence supporting the positive relationship between the frequency of digital tool usage and language learning outcomes among tertiary students. Additionally, the type of digital tool used was found to significantly influence language learning outcomes, with language learning apps demonstrating the highest efficacy. These findings highlight the importance of integrating digital tools into language education practices and tailoring instructional strategies to maximize their effectiveness.

DISCUSSION

The discussion section aims to interpret the results of the study, drawing on quantitative findings and inferential analyses to provide insights into the impact of digital tools and platforms on tertiary language education. This discussion will explore the implications of the



findings, address the research questions, and consider their significance in the context of existing literature.

Effectiveness of Digital Tools in Tertiary Language Education

The results of the study indicate a widespread adoption of digital tools and platforms in tertiary language education, with the majority of respondents reporting their use of various digital resources. Language learning apps emerged as the most commonly utilized digital tool, followed by online course management systems and social media for language practice. This finding aligns with previous research highlighting the popularity and accessibility of language learning apps (Gikas & Grant, 2013; Godwin-Jones, 2015). Moreover, the high frequency of usage reported by respondents underscores the integral role of digital tools in contemporary language education, facilitating access to authentic materials, enhancing learner autonomy, and promoting engagement (Lai & Zhao, 2006).

Perceptions of Effectiveness and Impact on Language Learning Outcomes

The study revealed generally positive perceptions of the effectiveness of digital tools for language teaching and learning, with a majority of respondents rating them as either very effective or effective. Specifically, digital tools were perceived to enhance language proficiency, promote intercultural competence, increase student engagement, improve learner autonomy, and facilitate collaborative learning. These findings corroborate existing research highlighting the benefits of digital technologies in language education, such as their ability to provide interactive and immersive learning experiences, cater to diverse learning styles, and foster communication skills (Stockwell, 2010; Warschauer & Meskill, 2000).

The significant correlation between the frequency of digital tool usage and language learning outcomes further supports the efficacy of digital tools in enhancing language proficiency. Students who reported using digital tools more frequently demonstrated higher mean language learning outcomes compared to those who used them less often. This finding suggests that consistent engagement with digital resources is associated with better language learning outcomes, underscoring the importance of integrating digital tools into language instruction to optimize learning experiences (Chen & Jang, 2010; Meskill & Anthony, 2010).

Impact of Digital Tool Types on Language Learning Outcomes

The analysis of variance (ANOVA) revealed a significant main effect of digital tool type on language learning outcomes, indicating that the type of digital tool used influences learning effectiveness. Post hoc tests further elucidated these differences, with language learning apps emerging as the most effective digital tool for enhancing language learning outcomes compared to virtual exchange platforms. While the reasons for this disparity warrant further investigation, it is plausible that the interactive and personalized nature of language learning apps contributes to their efficacy in improving language proficiency (Cui & Zhao, 2020). However, it is important to note that no significant differences were found between other pairs of digital tools, suggesting that the effectiveness of digital tools may vary depending on contextual factors and learner preferences (Peters & Reinders, 2010).

Predictors of Language Learning Outcomes

The regression analysis identified frequency of digital tool usage as a significant predictor of language learning outcomes, even after controlling for demographic variables and type of digital tool used. This finding underscores the importance of consistent and active engagement with digital resources in fostering language proficiency and highlights the need for educators to encourage and support learners in integrating digital tools into their language learning



routines (Kessler, 2018). While other factors such as age, gender, and educational role did not emerge as significant predictors in this analysis, their potential influence on language learning outcomes warrants further investigation in future research (Lai & Zheng, 2019).

Interpretation and Implications

In summary, the study's outcomes offer valuable insights into the role of digital resources and platforms within tertiary language education. The widespread embrace and favorable perceptions of these tools highlight their capacity to enrich language teaching and learning methodologies, enabling personalized, interactive, and stimulating learning experiences. The notable relationship between the frequency of digital tool utilization and language learning achievements emphasizes the significance of encouraging active engagement with these resources to enhance learning outcomes. Furthermore, the recognition of language learning apps as the most effective digital tool underscores the importance for educators to harness innovative technologies in crafting dynamic and adaptable learning environments tailored to diverse learner needs.

These findings hold several implications for educators, policymakers, and researchers in the field of language education. Firstly, educators should be prompted to integrate digital tools into their instructional practices, thereby granting learners access to a wide array of resources and opportunities for immersive language learning encounters. Secondly, policymakers are urged to invest in initiatives promoting digital literacy to ensure equitable access to digital tools and platforms for learners from all backgrounds. Lastly, researchers are encouraged to further explore the potential of digital technologies in language education, probing into their impact on learning outcomes, instructional approaches, and learner motivation, while devising effective strategies for their integration into language curricula.

Limitations and Future Directions

Despite the valuable insights gleaned from this study, it is important to acknowledge several limitations. Firstly, the study's reliance on self-reported data introduces the possibility of bias and inaccuracies. Future research endeavors could benefit from incorporating objective measures of language proficiency and learning outcomes to offer a more robust assessment of the impact of digital tools on language education. Moreover, the study predominantly focused on quantitative analyses, overlooking the rich qualitative data that could provide deeper insights into learners' experiences and perceptions of digital tools. Future investigations would benefit from adopting a mixed-methods approach to capture the multifaceted nature of language learning within digital environments.

In conclusion, this study adds to the researchers comprehension of the role played by digital tools and platforms in tertiary language education, underscoring their potential to improve language learning outcomes while nurturing engagement, autonomy, and intercultural competence among learners. Through the adept utilization of innovative technologies and pedagogical methodologies, educators can cultivate dynamic and inclusive learning environments that empower learners to flourish in the digital era.

CONCLUSION

The digital revolution in tertiary language education marks a significant shift in teaching methodologies, propelled by the incorporation of digital tools and platforms into educational practices. This research aimed to investigate the impact of digital technologies on language



education at the tertiary level, addressing key inquiries regarding the effectiveness of these tools, their influence on language learning outcomes, and the perceptions of educators and learners toward their integration into language curricula.

The outcomes of this study offer valuable insights into the role of digital tools and platforms in tertiary language education. Initially, the widespread adoption of digital tools among educators and learners underscores their potential to enrich language teaching and learning practices. A majority of respondents reported utilizing various digital resources, such as language learning apps, online course management systems, virtual exchange platforms, and social media for language practice. This suggests a growing acknowledgment of the advantages of digital technologies in providing tailored, interactive, and stimulating learning experiences.

Furthermore, the favorable perceptions of digital tools among respondents underscore their perceived efficacy in facilitating language learning. The majority viewed digital tools as effective or highly effective for language teaching and learning purposes, attributing their ability to enhance language proficiency, promote intercultural competence, boost student engagement, enhance learner autonomy, and facilitate collaborative learning. This indicates that digital tools are perceived as valuable assets in supporting language education and nurturing 21st-century skills crucial for success in today's globalized, digital landscape.

Moreover, the correlation observed between the frequency of digital tool usage and language learning outcomes underscores the importance of encouraging active engagement with digital resources to maximize learning effectiveness. Respondents who reported using digital tools more frequently tended to perceive greater improvements in language learning outcomes, including enhanced language proficiency, intercultural competence, student engagement, learner autonomy, and collaborative learning. This highlights the potential of digital tools to positively influence language learning outcomes when integrated effectively into educational practices.

Additionally, the identification of language learning apps as the most effective digital tool emphasizes the necessity for educators to leverage innovative technologies to create dynamic and adaptable learning environments. Language learning apps offer a plethora of features and functionalities, including interactive exercises, multimedia content, gamified elements, and personalized feedback, making them invaluable resources for language learners. Educators can harness the capabilities of language learning apps to provide learners with engaging and interactive language learning experiences tailored to their individual preferences and needs.

Implications and Recommendations

These findings have significant implications for educators, policymakers, and researchers in the field of language education. Firstly, educators should be encouraged to integrate digital tools into their teaching practices, providing learners with access to a diverse array of resources and opportunities for interactive and immersive language learning experiences. By harnessing innovative technologies, educators can develop dynamic and inclusive learning environments that empower learners to cultivate linguistic proficiency, intercultural competence, and digital literacy skills essential for success in the 21st century.

Secondly, policymakers should invest in the development and implementation of digital literacy initiatives to ensure equitable access to digital tools and platforms for all learners. Efforts should be made to address digital inequality and bridge the digital divide by offering



support and resources to underserved communities. Additionally, policymakers should endorse initiatives that advocate for the integration of digital technologies into language curricula and provide professional development opportunities for educators to enhance their digital literacy skills and pedagogical practices.

Lastly, researchers should continue to explore the potential of digital technologies in language education, investigating their impact on learning outcomes, pedagogical practices, and learner motivation. Future research endeavors should adopt a mixed-methods approach to capture the multifaceted nature of language learning in digital environments, combining quantitative analyses with qualitative insights to gain a comprehensive understanding of the role of digital tools in language education.

In conclusion, this study contributes valuable insights into the role of digital tools and platforms in tertiary language education, highlighting their potential to enhance language learning outcomes and foster engagement, autonomy, and intercultural competence among learners. By leveraging innovative technologies and pedagogical approaches, educators can create dynamic and inclusive learning environments that empower learners to thrive in the digital age. As we navigate the complexities of language education in the digital era, embracing the transformative potential of digital technologies is essential to unlock new possibilities for teaching, learning, and collaboration. Through collaborative efforts from educators, policymakers, and researchers, we can harness the power of digital tools to create a more inclusive, innovative, and equitable future for language education.

ACKNOWLEDGEMENT

I would like to express my sincere gratitude to all those who have contributed to this research article. Without their support and assistance, this work would not have been possible.

I would like to thank the participants of this study for their willingness to participate and share their experiences. Their contributions have provided crucial data and insights that have enriched the findings of this research.

I am indebted to Universiti Islam Malaysia for providing the necessary resources and facilities for conducting this study. Their support has been instrumental in the successful completion of this research.

Furthermore, I would like to express my appreciation to my colleagues and friends who have provided valuable input and suggestions during the course of this research. Their feedback and discussions have been invaluable in shaping the direction and focus of this article.

Lastly, I would like to acknowledge the support and understanding of my family and loved ones throughout this research journey. Their unwavering encouragement and belief in my abilities have been a constant source of motivation.

Once again, I extend my heartfelt thanks to all those who have contributed to this research article. Your support and collaboration have been instrumental in its successful completion.



REFERENCES

- Bach, M., & Smith, B. (2017). Digital Competence and Digital Literacy: New Approaches to Lifelong Learning and Employability. In m. Khan & n. V. Scarino (eds.), *Languages for the Future: Pedagogies of the Past, Visions of the Future* (pp. 139-152). Cambridge university press.
- Barrett, B. (2016). Virtual Reality and Augmented Reality in Language Education. *Tesl-ej*, 20(2), 1-10.
- Bates, A. W., & Sangrà, A. (2011). *Managing technology in higher education: Strategies for transforming teaching and learning*. John Wiley & Sons.
- Bates, A. W., & Sangrà, A. (2011). *Managing Technology in Higher Education: Strategies for Transforming Teaching and Learning*. John Wiley & Sons.
- Bax, S. (2003). CALL—past, present and future. *System*, 31(1), 13-28.
- Beldarrain, Y. (2006). Distance education trends: Integrating new technologies to foster student interaction and collaboration. *Distance education*, 27(2), 139-153.
- Belshaw, D. (2012). What is ‘digital literacy’? A pragmatic investigation. Ed.D. Thesis, durham university. Available at: <https://digitalliteraci.Es/files/dougbelshaweddthesisfinal.Pdf>
- Belz, J. A., & Thorne, S. L. (2006). Internet-mediated intercultural foreign language education. In s. Fotos & c. Browne (eds.), *New Perspectives on CALL for Second Language Classrooms* (pp. 159-175). Lawrence erlbaum associates.
- Bergmann, J., & Sams, A. (2012). *Flip Your Classroom: Reach Every Student in Every Class Every Day*. International Society for Technology in Education.
- Bishop, J. L., & Verleger, M. A. (2013). *The Flipped Classroom: A Survey of the Research*. In asee national conference proceedings, atlanta, ga.
- Bonk, C. J., & Graham, C. R. (2012). *The Handbook of Blended Learning: Global Perspectives, Local Designs*. John wiley & sons.
- Boyd, D., & Crawford, K. (2012). Critical Questions for Big Data: Provocations for a Cultural, Technological, and Scholarly Phenomenon. *Information, Communication & Society*, 15(5), 662-679.
- Cárdenas-Claros, M. S., & Dafouz-Milne, E. (2019). *Online Teaching in the Digital Age: A New Landscape for Language Teachers*. Peter lang publishing.
- Chapelle, C. A. (2001). *Computer applications in second language acquisition: Foundations for teaching, testing, and research*. Cambridge university press.
- Chen, C. H., & Jang, S. J. (2010). Motivation in online learning: Testing a model of self determination theory. *Computers in Human Behavior*, 26(4), 741–752.
- Chinnery, G. M. (2006). Emerging Technologies: Going to the MALL: Mobile Assisted Language Learning. *Language learning & technology*, 10(1), 9-16.
- Cui, Y., & Zhao, J. (2020). The effectiveness of language learning apps in EFL education: A meta-analysis. *Computer assisted language learning*, 33(3), 251–276.
- Dillenbourg, P., & Järvelä, S. (2014). *Collaborative learning: Cognitive and computational approaches*. Elsevier.
- Dillenbourg, P., & Järvelä, S. (2014). *Collaborative Learning: Cognitive and Computational Approaches*. Elsevier.
- Dooly, M. (2008). *Telecollaborative language learning: A guidebook to moderating intercultural collaboration online*. Peter lang.
- Dooly, M., & O’dowd, R. (2018). *Researching Online Interaction and Exchange in Language Education: A Critical Review of Concepts and Methods*. Springer.
- Ellis, R. (2003). *Task-based language learning and teaching*. Oxford university press.



- European Commission. (2018). GDPR: General Data Protection Regulation. European Commission.
- Ferrari, A. (2012). Digital Competence in Practice: An Analysis of Frameworks. Jrc technical reports. Luxembourg: Publications Office of the European Union.
- Garrison, D. R., & Vaughan, N. D. (2018). Blended Learning in Higher Education: Framework, Principles, and Guidelines. John Wiley & Sons.
- Gee, J. P. (2003). What video games have to teach us about learning and literacy. *Computers in Entertainment (CIE)*, 1(1), 20-20.
- Gibbons, P. (2002). Scaffolding language, scaffolding learning: Teaching second language learners in the mainstream classroom. Heinemann.
- Gikandi, J. W., Morrow, D., & Davis, N. E. (2011). Online formative assessment in higher education: A review of the literature. *Computers & Education*, 57(4), 2333-2351.
- Gikas, J., & Grant, M. M. (2013). Mobile computing devices in higher education: Student perspectives on learning with cellphones, smartphones & social media. *The Internet and Higher Education*, 19, 18-26.
- Godwin-Jones, R. (2015). Emerging technologies: Mobile apps for language learning. *Language Learning & Technology*, 19(3), 3-17.
- Godwin-Jones, R. (2018). Emerging technologies, MOOCs, and language education. *Language Learning & Technology*, 22(2), 9-16.
- Godwin-Jones, R. (2018). *Mobile Language Learning: A Handbook for Educators and Learners*. Routledge.
- Graham, C. R. (2013). Emerging Practice and Research in Blended Learning. In R. West (ed.), *Foundations of Learning and Instructional Design Technology* (pp. 155-179). Routledge.
- Hamari, J., Koivisto, J., & Sarsa, H. (2014). Does gamification work? A Literature Review of Empirical Studies on Gamification. In 47th Hawaii International Conference on System Sciences (pp. 3025-3034). Ieee.
- Hew, K. F., & Cheung, W. S. (2008). Attracting student participation in asynchronous online discussions: A case study of peer facilitation. *Computers & Education*, 51(3), 1111-1124.
- Hockly, N. (2021). *Blended learning*. Oxford University Press.
- Hsin, Y. C., & Cigas, J. (2013). Short-term memory, working memory, and executive function development: A longitudinal study. *Journal of Experimental Child Psychology*, 108(3), 523-536.
- Hubbard, P. (2013). CALL and complexity: Navigating the road ahead. In M. Thomas, H. Reinders, & M. Warschauer (eds.), *Contemporary Computer-Assisted Language Learning* (pp. 3-19). Bloomsbury Publishing.
- Johnson, L., Adams B., S., Estrada, V., M., & Freeman, A. (2019). *NMC Horizon Report: 2019 Higher Education Edition*. Educause.
- Jonassen, D. H. (1991). Objectivism versus constructivism: Do we need a new philosophical paradigm? *Educational Technology Research and Development*, 39(3), 5-14.
- Kapp, K. M. (2012). *The Gamification of Learning and Instruction: Game-Based Methods and Strategies for Training and Education*. John Wiley & Sons.
- Kessler, G. (2018). Digital literacies in language learning and teaching. *Calico Journal*, 35(2), 246-258.
- Kessler, G. (2018). Technology and the future of language teaching. *Foreign Language Annals*, 51(1), 171-185.
- Kim, C., Kim, M. K., Lee, C., Spector, J. M., & DeMeester, K. (2013). Teacher Beliefs and Technology Integration. *Teaching and Teacher Education*, 29, 76-85.



- Krajcik, J., & Blumenfeld, P. (2006). Project-based learning. In R. K. Sawyer (ed.), *The Cambridge Handbook of the Learning Sciences* (pp. 317-333). Cambridge university press.
- Kukulska-hulme, A., & Shield, L. (2018). An Overview of Mobile Assisted Language Learning: From Content Delivery to Supported Collaboration and Interaction. *Recall*, 30(1), 1-17.
- Lai, C., & Hwang, G. J. (2016). A self-regulated flipped classroom approach to improving students' learning performance in a mathematics course. *Computers & education*, 100, 126-140.
- Lai, C., & Zhao, Y. (2006). Noticing and text-based chat. *Language learning & technology*, 10(3), 102-120.
- Lai, C., & Zheng, D. (2019). Self-regulated vocabulary learning through mobile social media: Design and implementation. *Recall*, 31(2), 204-222.
- Lantolf, J. P., & Thorne, s. L. (2006). Sociocultural Theory and Second Language Learning. In B. Vanpatten & J. Williams (eds.), *Theories in Second Language Acquisition: An Introduction* (pp. 201-224). Routledge.
- Lee, J., & Kim, C. (2014). An analysis of the technology acceptance model in understanding university students' behavioral intention to use e-learning. *Educational Technology & Society*, 17(3), 211-223.
- Lee, S. Y., & Kim, M. K. (2014). Effects of Multimedia-Assisted Instructional Strategy in Enhancing Learner's Achievement and Motivation in Tertiary Education. *Educational Technology Research and Development*, 62(4), 431-451.
- Levy, M., & Stockwell, G. (2006). *CALL Dimensions: Options And Issues In Computer Assisted Language Learning*. Lawrence Erlbaum Associates.
- Levy, M., & Stockwell, G. (2020). *CALL Dimensions: Options And Issues In Computer Assisted Language Learning*. Routledge.
- Liaw, M. L., & English, K. (Eds.). (2018). *Handbook Of Research On Foreign Language Education In The Digital Age*. Igi Global.
- Liaw, M. L., & English, K. (Eds.). (2018). *Handbook Of Research On Foreign Language Education In The Digital Age*.
- Merchant, Z. (2017). *Digital Learning: Strengthening And Assessing 21st Century Skills, Grades 5-8*. Corwin Press.
- Meskill, C., & Anthony, N. (2010). Foreign Language Learning With CMC: Forms Of Online Instructional Discourse In A Hybrid Russian Course. *Calico Journal*, 27
- Mishra, P., & Koehler, M. J. (2006). Technological Pedagogical Content Knowledge: A Framework for Teacher Knowledge. *Teachers College Record*, 108(6), 1017-1054.
- Molka-Danielsen, J., & Daniels, M. (2016). *Mobile Learning: Structures, Agency, Practices*. Springer.
- Nunan, D. (2004). *Task-Based Language Teaching*. Cambridge University Press.
- O'dowd, R. (2013). Telecollaboration And CALL. In M. Thomas, H. Reinders, & M. Warschauer (Eds.), *Contemporary Computer-Assisted Language Learning* (Pp. 199-213). Bloomsbury Publishing.
- O'dowd, R., & Ritter, M. (2006). Understanding And Working With 'Failed Communication' In Telecollaborative Exchanges. *Calico Journal*, 23(3), 623-642.
- Prensky, M. (2009). Digital Natives, Digital Immigrants. *On The Horizon*, 9(5), 1-6.
- Ribble, M. (2015). *Digital Citizenship In Schools: Nine Elements All Students Should Know*. International Society For Technology In Education.
- Selwyn, N. (2010). *Schools And Schooling In The Digital Age: A Critical Analysis*. Routledge.
- Selwyn, N. (2010). *Schools and Schooling in the Digital Age: A Critical Analysis*. Routledge.



- Stockwell, G. (2017). Language teaching and technology: FIT and the change of language learning paradigms. *Language Learning & Technology*, 21(3), 9–15.
- Stockwell, G. (2018). Mobile-Assisted Language Learning. In M. Thomas, H. Reinders, & M. Warschauer (Eds.), *Contemporary Computer-Assisted Language Learning* (Pp. 139 160). Bloomsbury Publishing.
- Stockwell, G. (2018). Mobile-Assisted Language Learning: A Selected Annotated Bibliography Of Implementation Studies 1994-2018. *Language Learning & Technology*, 22(3), 11-23.
- Thomas, J. W. (2000). *A Review Of Research On Project-Based Learning*. Autodesk Foundation.
- Thorne, S. L., & Reinhardt, J. (2017). Digital Technologies And The Future Of Language Learning And Teaching. *Foreign Language Annals*, 50(1), 1-8.
- Tucker, B. (2012). The Flipped Classroom. *Education Next*, 12(1), 82-83.
- UNESCO. (2017). *Digital Skills for Life and Work*. UNESCO Publishing.
- Unesco. (2018). *Policy Guidelines For Mobile Learning*. Retrieved From <https://unesdoc.unesco.org/ark:/48223/pf0000248043>.
- Vygotsky, L. S. (1978). *Mind In Society: The Development Of Higher Psychological Processes*. Harvard University Press.
- Wang, L. (2018). Mobile-Assisted Language Learning: A Review Of The Literature And Future Directions. *International Journal Of Mobile And Blended Learning*, 10(3), 1-17.
- Ware, P., & O'dowd, R. (2008). Peer Feedback On Language Form In Telecollaboration. *Language Learning & Technology*, 12(1), 43-63.
- Warschauer, M. (2003). *Technology and Social Inclusion: Rethinking the Digital Divide*. MIT Press.
- Warschauer, M. (2003). *Technology and social inclusion: Rethinking the digital divide*. The MIT Press.
- Warschauer, M. (2019). *Technology And Social Inclusion: Rethinking The Digital Divide*. Mit Press.
- Warschauer, M., & Meskill, C. (2000). Technology And Second Language Learning. In J. Rosenthal (Ed.), *Handbook Of Undergraduate Second Language Education* (Pp. 303 318). Routledge.



116-102

ADVANCED SOFTWARE-BASED TEACHING AND LEARNING FOR ARCHITECTURAL STUDIO MODULE

Abu Dzar bin Samsudin

Kulliyyah of Architecture and Environmental Design (KAED)
8, Jalan 51a/223, Seksyen 51a, 46100 Petaling Jaya, Selangor
Email: abudzar.samsudin@city.edu.my, M:(+6)011-27095831

Siti Nur Hidayatul Ain Bt. M. Nashruddin

Faculty of Architecture and Built Environment
8, Jalan 51a/223, Seksyen 51a, 46100 Petaling Jaya, Selangor Email:
nur.hidayatul@city.edu.my, M:(+6)013-6687303

Norsafiah Norazman

Jabatan Ukur Bangunan
Pusat Pengajian Perumahan, Bangunan dan Perancangan (PPBPP) Universiti Sains Malaysia.
Email: safiahazman@usm.my, M:(+6)018-2914071

Nurul Aishah Binti Ghazali

Faculty of Architecture and Built Environment
8, Jalan 51a/223, Seksyen 51a, 46100 Petaling Jaya, Selangor Email:
nurul.aishah@city.edu.my, M:(+6)011-26102241

Sapinah Danial

Faculty of Architecture & Built Environment
8, Jalan 51a/223, Seksyen 51a, 46100 Petaling Jaya, Selangor
Email: sapinah@city.edu.my, M:(+6)012-6606481

Abdul Razak bin Abd Aziz

Faculty of Architecture & Built Environment
8, Jalan 51a/223, Seksyen 51a, 46100 Petaling Jaya, Selangor
Email: razak.abdaziz@city.edu.my, M:(+6)012-2279646

ABSTRACT

The dearth of qualified specialist workers in AEC industry with skillful by using advanced technology to serve the industry needs is seen as one of the main issues facing the design, construction, and engineering industries as BIM/AI/VR/AR has emerged as the industry international standard. Therefore, it is to fill the gap for career prospect in the rapid development country, Malaysia from the foundation level. The main objective of this study is to covers current educational trend for studio module as a core subject to provide sets of skill students with integrative pedagogical objectives are achieved through BIM/AI/VR/AR. The research paper finding based on previous selected literature reviews. In-depth interview with the educators and expertise from the related field is still in progress. The new framework of architecture design process in relation to case study and advance software, that are just starting out for fundamental module in architecture and built environment course. In addition, the paper



assesses potential for future trending role in the AEC industry based on actual case studies and lessons learned and suggested practical approaches to integrating BIM/AI/VR/AR in education platform and the research still on going.

Keywords: AEC (Architecture, Engineering, Construction), BIM/AI/VR/AR (Building Information Modeling, Artificial Intelligent, Virtual Reality, Augmented Reality, Education, Advanced Software.

INTRODUCTION

This paper holds significance due to the prevalent trend within the architecture academic sphere, where most professionals either hail from practical backgrounds or are architectural graduates utilizing software tools to streamline their work processes, enhancing efficiency and creativity. Teaching with advanced software necessitates not only technical proficiency but also a specific mindset, attitude, and pedagogical skills to effectively impart knowledge and motivate students to transcend mere technical proficiency. In Malaysia, architectural education has embraced the integration of advanced software across various subjects, notably in the pivotal Design Studio. This paper aims to stimulate a broader conversation surrounding the role of advanced software in education, emphasizing its potential to foster critical thinking and innovation beyond producing assembly-line professionals for the construction industry. It underscores that architecture is not just a technical discipline but an amalgamation of science and art, deeply rooted in human rituals, beliefs, and values.

This research focuses on the application of advanced software specifically for the Architectural design studio subject course. This subject course is the core subject for Architectural Design course, it is the most important subject for the course. Thus, choosing it brings a great significant for the outcome of research.

MALAYSIA ARCHITECTURAL EDUCATION

The Board of Architecture Malaysia (LAM) and the Malaysian Institute of Architects (PAM) are two organizations that play varying roles in architectural education in Malaysia. The LAM is a statutory responsible in determining the standard for entry into the architectural profession and the accreditation of programme of study in architecture. For this purpose, the Council of Architectural Education Malaysia (CAEM) was formed under the auspices of LAM to regulate all matters relating to architectural education (LAM, 2005). The PAM is an architectural organization representing architects committee on education and takes an active role to coordinate, facilitate and advance the pursuit of excellence in architectural education in Malaysian institutions and to educate the future architects (student/graduate members of PAM) in preparing for professional practice and the building industry (PAM, 2002)

The curricula for Malaysian schools of architecture are generally based on the British system with LAM Part I and Part II (equivalent to RIBA Part I and Part II respectively) qualification requirements. Upon graduating from a school of architecture that is accredited by LAM (4 schools in Malaysia, 15 in Australia, 1 in Hong Kong, 1 in Eire Dublin, 2 in New Zealand and 35 in the UK), graduates are exempted from having to sit for the LAM Part I and Part II Examinations and are eligible to enrol as an “Architect” with LAM. After gaining a minimum of 2 years of postgraduate working experience under the supervision of a Professional Architect, graduates a eligible to sit for LAM Part III Professional Practice Examination



conducted by LAM. Upon passing the LAM Part III Examination, one can register as a Corporate Member with PAM and as a “Professional Architect” with LAM (LAM, 2005).

ARCHITECTURE DESIGN STUDIO SUBJECT

The architectural design studio functions as a unique learning environment with distinct processes tailored for design, as noted by Schön (2016). Architects are tasked with crafting human-centric living spaces for various purposes, as highlighted by Abdullah et al. (2011). Typically, the studio is overseen by a Studio Master (Lecturer) and supplemented by additional lecturers. Each studio is structured around a specific design brief that guides students throughout the semester. Central to this educational setting is the architectural design process.

Within this process, the architect enjoys the autonomy and creative freedom to develop design ideas and concepts, as emphasized by Lawson (2006). These concepts undergo refinement through multiple tutoring sessions, providing architectural students with exposure to expert designers within the studio environment, as observed by Cennamo et al. (2011). The methodology of "reflection on action" is prevalent in architectural design studios, wherein students receive direct feedback from their design tutors, as per Schön (2016). The design process typically encompasses distinct phases such as the Design Phase, Schematic Design Phase, and Design Development. Educators in architecture design studios often traverse these phases, each marked by unique sub-phases that vary across different educational institutions or pedagogical approaches. This structured progression allows for comprehensive exploration and refinement of design ideas, fostering students' growth and development as aspiring architects.

ARCHITECTURAL DESIGN SOFTWARE

Architecture studios utilize a variety of software tools throughout the design process to facilitate different stages of architectural projects. In general, there are 3 categories of software that is usually used in architectural design projects, they are Computer-Aided Design (CAD) Software, Visualization and Rendering Software and Immersive Experience software. Each of these categories has its own roles to explore the design project.

Computer-Aided Design (CAD) Software

CAD software forms the foundation of architectural design. It allows architects to create precise 2D drawings and 3D models of buildings, structures, and components. The traditional CAD usually consists of using 2D software like AutoCAD software and continued with 3D software like SketchUp. Yet in recent times there are being much more advanced software that utilize both 2D and 3D in one software, that categories of software are called Building Information Modelling (BIM).

Visualization and Rendering Software

Visualization software is essential for creating photorealistic images and animations of architectural designs. These tools help architects communicate their ideas to clients and stakeholders effectively. Visualization software focuses on creating graphics and rendering designs using 2D or 3D software, allowing professionals to visualize interior and exterior designs, lighting, texture, and geography before actual development. On the other hand, rendering software involves building virtual scenes with 3D objects, setting up lighting and materials to make them look realistic, and generating final images or animations based on the interpretation of the rendering program. These software tools play a crucial role in enhancing



the design process, improving communication, and saving time and costs by providing a visual representation of concepts and designs before execution (Stefan, n.d). The software of visualization and rendering are consisting of 2d and 3d rendering. 2d rendering like photoshop are widely use as it has a wide range of capabilities to render a 2d images. 3d rendering software unlike 2d rendering had many options like vray, 3d max, Lumion and enscape. The rendering nowadays is also encompassing of video rendering which are flourishing with software like Lumion, enscape, D5, Twinmotion and others. As much as the Visualization and Rendering Software are on the rise, there are now a far more advance software that are quickly in the rise and with the help of Artificial Intelligence 2d and 3d rendering are much faster in rendering and had a wide range of flexibility.

Immersive Experience software

Immersive technology transforms the digital experience by bringing together the virtual with users' sight, sound and event touch. Ranging from virtual reality and augmented reality to haptics, immersive technologies are new ways of creating, displaying and interacting with applications, content and experiences. Immersive technologies allow a person to feel part of an artificial, simulated environment – for example, immersive theatre requires the audience to interact with the set, props and actors, while an immersive air control dashboard may allow the operator to see and interact with real-time monitoring data.

BIM as an Education Platform in Architecture Study

The field of architecture, engineering, and construction (AEC) has seen a significant shift in the way professionals design, build, and maintain buildings with the introduction of Building Information Modeling (BIM). (Liu et al., 2019) BIM provides a platform that combines academic knowledge with practical application, which enhances the educational experience for architectural students. Educational establishments can develop proficient BIM practitioners who can fulfill industry demands by including students in BIM competitions and projects. (Suwal et al., n.d.)

BIM serves as a valuable education platform in architecture study:

1. Integration of Theory and Practice: BIM competitions allow students to apply theoretical concepts learned in classrooms to real-world scenarios.
2. Skill Development: Participation in BIM projects helps students develop essential skills such as collaboration, problem-solving, and project management. (Yilei Huang, 2018)
3. Exposure to Industry Standards: Working with BIM exposes students to industry-standard software and practices, giving them a competitive edge in the job market.
4. Innovation and Creativity: Innovation in the design and building processes is fostered by BIM. Students can push the limits of conventional architectural processes, experiment with novel concepts, and try out various solutions.

Key Factors Influencing BIM Competition Results:

1. Behavioral Intention to Use BIM: The degree to which students embrace and apply BIM technology determines how well they do in contests. Better results come from having a positive attitude toward BIM.
2. Perceived Behavioral Control: Students' performance is influenced by how confident they are in their capacity to use BIM technologies. Competition performance is affected by one's confidence in using software and carrying out tasks.
3. Facilitating Conditions: Successful participation in BIM competitions is influenced by a variety of factors, including easy access to information,



instructor support, and supportive learning environments. Students' abilities are improved by adequate resources and instruction.

Optimizing Student Participation:

- Increasing awareness about BIM through publicity campaigns
- Strengthening teaching facilities for hands-on training
- Developing integrated curriculum systems that incorporate BIM technology.
- Providing comprehensive teacher training on BIM tools and methodologies

In conclusion, Institutions may foster an environment that helps students succeed in BIM competitions and gain important skills for their future jobs in architecture by addressing these factors. BIM also can be an interactive medium when combining with VR medium. (Kieferle & Woessner, 2015)

AI as an Education Platform in Architecture Study

Artificial intelligence (AI) is transforming the teaching of architecture by providing cutting-edge resources and learning environments that improve instruction and equip students for the rapidly changing architecture business. A deeper comprehension of intricate architectural concepts, better design processes, and increased creativity are just a few advantages of integrating AI into architecture studies. Students can gain important skills in data analysis, computational design, and moral decision-making by using AI as a teaching tool. AI technologies also give students the ability to keep ahead of market trends, maximize project outcomes, and investigate new design possibilities. Educators can enable pupils to interact with cutting-edge technology and get a competitive advantage in the job market by incorporating AI into the curriculum. (Milovanovic et al., n.d.)

AI serves as a valuable education platform in architecture study:

1. **Enhanced Design Capabilities:** AI tools can generate renderings, floor plans, and other architectural representations quickly and accurately based on text prompts or data inputs. By leveraging AI, students can explore a wide range of design possibilities and experiment with different concepts in a shorter amount of time. (Anderson et al., 2003)
2. **Efficiency and Time-Saving:** AI technologies streamline various aspects of the design process, saving time and effort for both students and educators.
3. **Innovation and Exploration:** AI opens new avenues for innovation in architecture by enabling students to push the boundaries of traditional design practices. (Stoakley et al., 1995)
4. **Innovation and Creativity:** AI can generate designs based on existing data and patterns.
5. **Adaptability and Collaboration:** Architects must collaborate with various stakeholders, including clients, engineers, and builders.
6. **Sustainability and Social Responsibility:** Education in architecture provides the foundation for designing environmentally conscious and socially impactful structures.
7. **Cultural Preservation:** Architecture plays a significant role in preserving cultural heritage and identity.

In conclusion, studying architecture is still crucial for fostering creativity, addressing ethical issues, promoting human-centered design principles, guaranteeing sustainability practices, preserving cultural heritage, and preparing architects to effectively tackle complex societal challenges, even though AI technologies are revolutionizing the field of architecture by improving design capabilities.



Virtual Reality (VR) and Augmented Reality (AR) for Education Platform in Architecture Study

A technology known as augmented reality (AR) creates a mixed reality by superimposing computer-generated virtual objects and pictures over the actual world. In the field of architecture and construction (AC) education, it is regarded as a relatively new tool because of its capacity to create connections between the virtual and physical worlds, improving students' perceptions of the latter and offering chances for interaction with them in authentic settings. Compared to virtual reality (VR), augmented reality (AR) is more affordable and accessible since it can be used with readily available hardware and software. For comprehending difficult spatial ideas, astronomical occurrences, abstract themes, and hazardous circumstances, augmented reality technology can offer a productive learning environment. It is widely utilized in all educational levels, from K–12 to postsecondary. Augmented reality (AR) offers a viable remedy for comprehension problems in architecture education.

AR enables architecture students to have a more engaging and dynamic learning environment. Students able to envision and comprehend architectural designs and concepts more clearly when digital 3D models and information are superimposed over the actual environment (Hajirasouli and Banihashemi 2022) (Alp, Yazici, and Oner 2023). This helps improve their spatial awareness, graphical skills, and ability to apply classroom knowledge to real-world contexts. Their capacity to apply classroom information to real-world circumstances, their graphical abilities, and their spatial awareness all increase as a result.

Even in cases when design students are geographically distant, augmented reality (AR) facilitates remote communication and collaboration. Group work and conversations are facilitated by the ability for students to examine and interact with the same virtual architectural models together (Hajirasouli and Banihashemi 2022). They are more equipped for the teamwork required in the architectural field as a result. In architectural programs, augmented reality (AR) can improve conventional teaching techniques. Instructors may use augmented reality (AR) to provide students a more dynamic and realistic method to experience designs, rather than only depending on static 2D drawings and physical models (Jaramillo 2022). Thus, better application and retention of the knowledge result from this.

Important skills like cost estimation, safety assessment, and design iteration are also developed by using AR in architecture education. Students can precisely estimate expenses, recognize potential risks, and make changes prior to the start of construction by superimposing digital data and models onto construction sites (Mortice 2022) All things considered, the learning process is changing because of the incorporation of AR technology into architectural education. It better equips students for the field by giving them a more in-depth, hands-on, collaborative understanding of architectural design and construction (Hajirasouli and Banihashemi 2022).

Software related to advance software for Architectural Education

Nowadays there is much more software that architectural student can utilize in their design project. Below are some examples of advanced software that could be used by architectural students on their design project. There is also an added feature in the design advance software which is related to immersive experience for the designer and viewer to experience design project in new dimension.

Table 2 : Advance architectural Design Software



Software	Product	
Computer-Aided Design (CAD) Software	RoomSketcher Grasshopper	CAD software forms the foundation of architectural design. It allows architects to create precise 2D drawings and 3D models of buildings, structures, and components
Visualization and Rendering Software	Midjourney Adobe Firefly ArchitectGPT	Visualization software is crucial for generating photorealistic images and animations of architectural designs, aiding architects in
	Visoid Sketch2Render Genera.so	effectively communicating their concepts to clients and stakeholders.
Immersive Experience software	<ul style="list-style-type: none"> • Virtual Reality Storyboard VR SmartReality Autodesk LIVE • Augmented Reality Arki Hutch 	<p>VR technology immerses users in a computer-generated 3D world via headsets that track their movements and display stereoscopic images, creating a sense of physical presence in virtual space.</p> <p>Augmented Reality (AR) in architecture involves overlaying digital information, such as architectural models or design elements, onto the physical world in real-time.</p>

METHODOLOGY

The method of the research is qualitative. In the literature review of the architectural studio subject utilizing Building Information Modelling (BIM), Artificial Intelligence (AI), Virtual Reality (VR), and Augmented Reality (AR), five themes were identified. These themes provide a comprehensive overview of how these technologies are shaping the field of architecture and design. There are students, lectures and expertise were in-depth interviewed and still ongoing for results analysis.



Theme 1: Integration of BIM in Architectural Design One of the key themes identified in the literature review is the integration of BIM in architectural design processes. BIM has revolutionized the way architects plan, design, construct, and manage buildings. By using BIM software, architects can create detailed 3D models that contain information about every aspect of a building's lifecycle.

Theme 2: Role of AI in Architectural Decision-Making Another important theme highlighted in the literature review is the role of Artificial Intelligence in architectural decision-making. AI algorithms can analyze vast amounts of data to optimize building designs for factors such as energy efficiency, sustainability, and occupant comfort. AI tools also enable architects to generate innovative design solutions based on complex parameters.

Theme 3: Enhancing Design Visualization with VR Virtual Reality (VR) emerged as a significant theme in the literature review, focusing on how it enhances design visualization in architecture. VR technology allows architects to immerse themselves and their clients in realistic virtual environments, providing a more immersive and interactive design experience. This technology enables stakeholders to better understand spatial relationships and make informed decisions during the design process.

Theme 4: Augmented Reality for Construction Management Augmented Reality (AR) was identified as a theme that plays a crucial role in construction management within architectural projects. AR applications overlay digital information onto physical spaces, allowing construction teams to visualize building components in real-time on-site. This technology improves communication among project stakeholders, enhances collaboration, and streamlines construction processes.

Theme 5: Collaborative Design Environments The final theme extracted from the literature review is collaborative design environments facilitated by BIM, AI, VR, and AR technologies. These tools enable architects, engineers, contractors, and clients to work together seamlessly throughout the project lifecycle. Collaborative platforms enhance communication, coordination, and decisionmaking among multidisciplinary teams involved in architectural projects.

By analysing these five themes derived from the literature review of architectural studio subjects using BIM, AI, VR, and AR technologies, it becomes evident how these advancements are reshaping architectural practice by improving efficiency, creativity, communication, and decisionmaking processes.

DISCUSSION

Based on the literature and on-going interviews in the design process of architectural design project there is a potential to insert advance software in all of the phases of architecture design process. The diagram one (1) below showed the architecture design process and its relationship to the suitable advance software. Diagram two (2) showed example of advance software application for each category of software.



**Computer-Aided Design
 (CAD) Software**

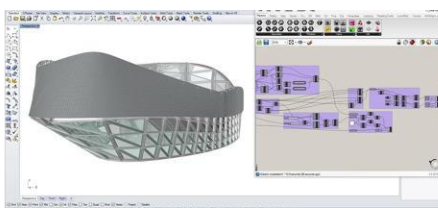

Grasshopper

**Visualization and
 Rendering Software**



Midjourney

**Immersive Experience
 software**



Augmented Reality

Virtual Reality

Diagram 2 : Example of advanced software application for each category of software.

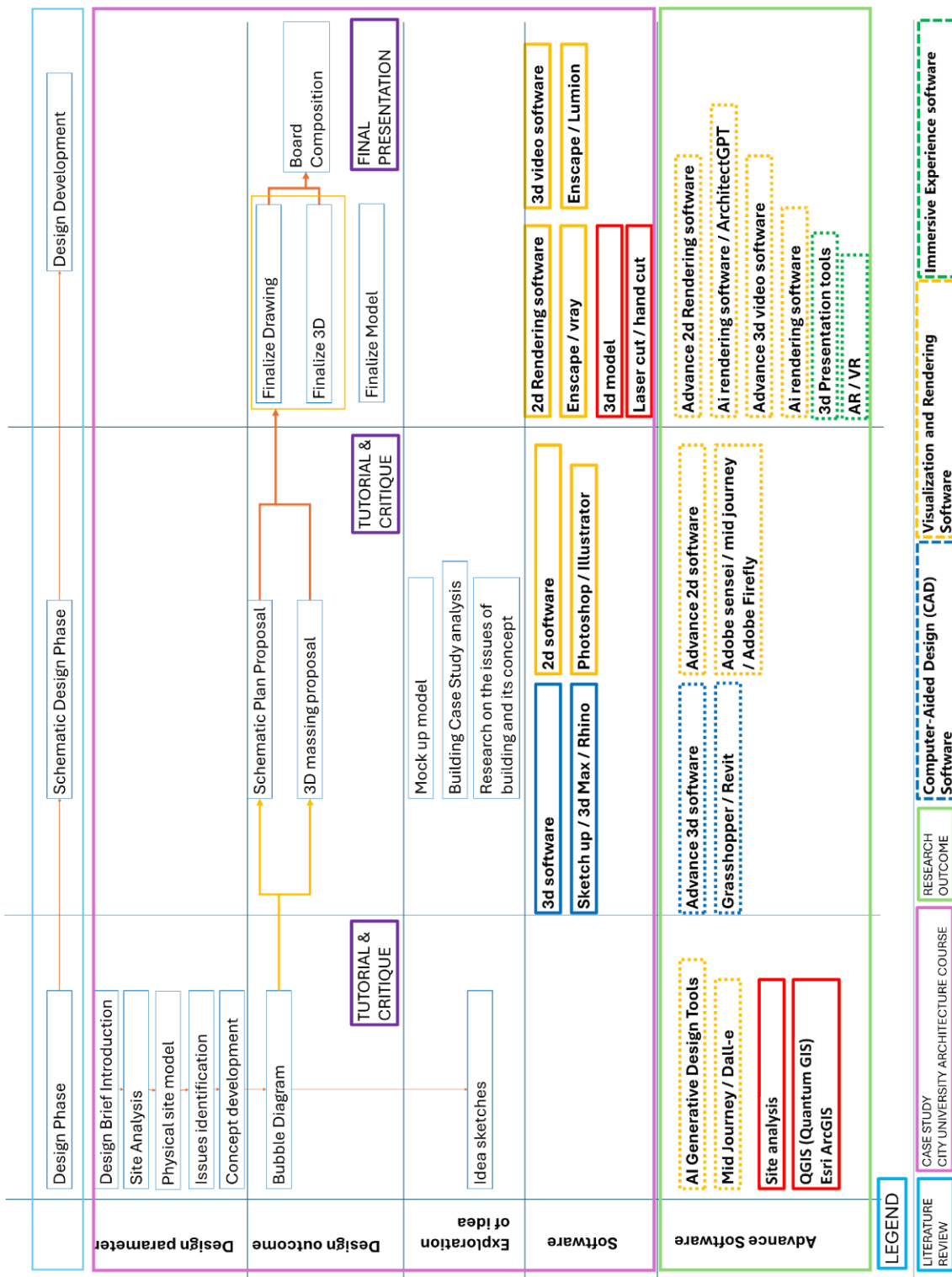

Diagram 1: Framework of architecture design process in relation to literature review and advance software

The case studies clearly demonstrate that advanced software plays a crucial role throughout the entire architecture design process. These software tools encompass three main categories: computer-aided design (CAD) software, visualization and rendering software, and immersive experience software. Upon closer examination, it becomes evident that visualization and



rendering software are the easiest to implement, particularly due to their integration with artificial intelligence (AI). These tools offer intuitive interfaces and automated features that simplify the design visualization process. Immersive experience software ranks as the second easiest category to implement, albeit requiring specific hardware for its application. For instance, VR applications necessitate VR peripherals like the META QUEST 2 and PICO 4 for optimal user experience.

Conversely, computer-aided design (CAD) software emerges as the most challenging category to implement due to its steep learning curve. These tools, such as Grasshopper as shown in Table 1, often utilize visual programming methods that require comprehensive training and proficiency to effectively apply in architectural design projects. Overall, while all three categories of advanced software offer distinct advantages in the architecture design process, careful consideration of their implementation requirements and learning curves is essential to maximize their potential impact on design outcomes.

CONCLUSION

Implementing advanced software in architectural design courses can greatly enhance the complexity and explorative nature of students' design outcomes. However, it is important to consider the learning curve associated with these tools. This research suggests starting with visualization and rendering software, as well as immersive experience software, due to their relatively easier learning curves. These tools allow students to visualize and present their designs in realistic contexts, enhancing their understanding of spatial relationships and materiality. As students become more comfortable with these tools, they can gradually transition to advanced software from computeraided design (CAD) software. Advance software from CAD software offers extensive capabilities for creating precise 2D drawings and 3D models, but it may require a more advanced learning experience. Therefore, it is recommended to introduce advanced CAD software during semester breaks or as students progress in their studies. The application of advanced software in architecture design courses introduces a new paradigm for both lecturers and students. It is crucial for educators to stay updated on the latest advancements in software technology so they can effectively teach these tools and incorporate them into the curriculum. Likewise, students should continuously update their knowledge and skills in using these software tools to explore new methods and approaches in architectural design. By embracing advanced software, both educators and students can push the boundaries of architectural design and innovation. The new framework of architecture design process in relation to literature review and advance software was proposed.

REFERENCES

- Abdullah, N. A. G., Beh, S. C., Tahir, M. M., Ani, A. I. C., & Tawil, N. M. (2011). Architecture design studio culture and learning spaces: A holistic approach to the design and planning of learning facilities. *Procedia - Social and Behavioral Sciences*, 15, 27–32.
- Cennamo, K., Brandt, C., Scott, B., Douglas, S., McGrath, M., Reimer, Y., & Vernon, M. (2011). Managing the complexity of design problems through studio-based learning. *Interdisciplinary Journal of Problem-Based Learning*, 5(2), 12–36.
- Childs, P. (2024, April 24). Everything you need to know about immersive technology. Digital Catapult. <https://www.digicatapult.org.uk/expertise/blogs/post/everything-to>



- [know](#)aboutimmersivetechology/#:~:text=Immersive%20technology%20transforms%20digital,with%20a%20pplications%2C%20content%20and%20experiences.
- Experience in an Architectural Design Studio.” Multimedia Tools and Applications 82(29):45639– 57. doi: 10.1007/s11042-023-15476-w.
- Hajirasouli, Aso, and Saeed Banihashemi. 2022. “Augmented Reality in Architecture and Construction Education: State of the Field and Opportunities.” International Journal of Educational Technology in Higher Education 19(1):39. doi: 10.1186/s41239-022-00343-9. Jaramillo, Sofia. 2022. “Augmented Reality in Architecture: Applications and Prospective.”
- Kieferle, J., & Woessner, U. (2015). BIM Interactive—About combining BIM and Virtual Reality—A Bidirectional Interaction Method for BIM Models in Different Environments. 69–75. <https://doi.org/10.52842/conf.ecaade.2015.1.069>
- Lawson, B. (2006). How designers think: The design process demystified. Architectural Press.
- LAM. (2005). “Board of Architects
- Liu, Z., Lu, Y., & Peh, L. C. (2019). A Review and Scientometric Analysis of Global Building Information Modelling (BIM) Research in the Architecture, Engineering and Construction (AEC) Industry. <https://doi.org/10.20944/preprints201907.0026.v1>
- Malaysia” Retrieved 5 September 2006, from <http://www.lam.gov.my>
- Mortice, Zach. 2022. “AR in Architecture Unites Design and Construction—in Virtual and Real Worlds.”
- PAM. (2002). ”Malaysian Institute of Architects” Retrieved 5 September 2006, from <http://www.pam.org.my>
- SCHÖN, D. A. (2016). *The reflective practitioner: How professionals think in action*. Routledge
- Stefan. (n.d.) *What is 3D Rendering? | Understanding the 3D Visualization Process*. <https://www.realspace3d.com/resources/what-is-3d-rendering/>
- Suwal, S., Jäväjä, P., Rahman, A., & Gonzalez, V. (n.d.). EXPLORING BIM-BASED EDUCATION PERSPECTIVES.
- Yilei Huang. (2018). A Review of Approaches and Challenges of BIM Education in Construction Management. Journal of Civil Engineering and Architecture, 12(6). <https://doi.org/10.17265/1934-7359/2018.06.001>
- Liu, Z., Lu, Y., & Peh, L. C. (2019). A Review and Scientometric Analysis of Global Building Information Modelling (BIM) Research in the Architecture, Engineering and Construction (AEC) Industry. <https://doi.org/10.20944/preprints201907.0026.v1>
- Suwal, S., Jäväjä, P., Rahman, A., & Gonzalez, V. (n.d.). EXPLORING BIM-BASED EDUCATION PERSPECTIVES.



059-035

**KETAGIHAN INTERNET DALAM KALANGAN MURID SEKOLAH
RENDAH DI KUALA LUMPUR DAN KESANNYA TERHADAP PENCAPAIAN
AKADEMIK**

Ani Zalawati Zakaria
Fakulti Pendidikan, Universiti Kebangsaan Malaysia,
43600 UKM Bangi, Selangor, Malaysia
Email: anizalawati123@gmail.com, Tel: 011-16421078

Prof. Dato' Ts. Dr. Norazah Mohd. Nordin
Fakulti Pendidikan, Universiti Kebangsaan Malaysia,
43600 UKM Bangi, Selangor, Malaysia
Email: drnmn@ukm.edu.my, Tel: 019-3328704 *Pengarang bersama

ABSTRAK

Ketagihan internet menjurus kepada murid yang mengalami kebergantungan terhadap internet dan teknologi digital serta memberi impak negative terhadap kesihatan mental yang serius. Tujuan kajian ini adalah untuk mengkaji hubungan antara tahap ketagihan internet dengan pencapaian akademik murid sekolah rendah serta untuk menganalisis kesan ketagihan internet dengan pencapaian akademik murid sekolah rendah. Kajian ini merangkumi tiga objektif iaitu mengenal pasti tahap ketagihan internet, mengenal pasti hubungan antara ketagihan internet dengan pencapaian akademik serta bagi mengenal pasti kesan ketagihan internet dengan pencapaian akademik dalam kalangan murid sekolah rendah di Kuala Lumpur. Kajian ini menekankan pendekatan kuantitatif dengan menggunakan kaedah tinjauan yang bertunjangan pada borang soal selidik. Sampel kajian ini terdiri daripada 80 orang murid dari Sekolah Rendah Kebangsaan Jalan Bellamy, Kuala Lumpur. Kajian ini menggunakan perisian SPSS versi 21 untuk menganalisis data secara deskriptif dan inferensi. Sesungguhnya, dapatan kajian membuktikan bahawa tahap antara ketagihan dari aspek keasyikan emosi dan kognitif serta tahap ketagihan dari aspek hilang kawalan dan gangguan terhadap kehidupan seharian dalam kalangan murid sekolah rendah di Kuala Lumpur dengan pencapaian akademik berada di tahap yang rendah dengan nilai min respons sampel sebanyak 2.05 dan 2.22 masing-masing. Justeru itu, pemantauan dan penelitian lanjut mengenai isu ketagihan internet dalam pencapaian akademik di Malaysia terutama di sekolah rendah perlu diambil kira pada kajian masa hadapan bagi memastikan kesejahteraan murid dan memastikan mereka dapat mencapai potensi akademik yang cemerlang dan sosial mereka yang sejahtera secara holistic.

Kata Kunci; Ketagihan Internet, Sekolah Rendah, Tahap Pencapaian, Kesan, Prestasi, Kuantitatif.

1. Pendahuluan

Di Malaysia peranti mudah alih menjadi trend yang popular dalam kalangan kanak-kanak yang melibatkan permainan digital mudah alih. Dorongan untuk berteknologi dalam setiap hari dalam kehidupan kanak-kanak di Malaysia tersemam kerana mereka sering



melihat orang dewasa terlibat dalam pelbagai kegiatan melalui teknologi digital. Sehubungan dengan itu, Ketagihan internet adalah keadaan di mana seseorang menggunakan internet secara berlebihan sehingga ia memberi kesan buruk kepada diri mereka. Ia melibatkan tingkah laku kompulsif atau sukar dikawal. Orang yang selalu online boleh dianggap ketagih. Walaupun ketagihan internet dikenali sebagai masalah, pakar masih belum sepakat untuk menganggapnya sebagai jenis ketagihan tersendiri (Joorabchi et al. 2022).

Pada era globalisasi, ketagihan terhadap permainan video merupakan penyakit yang berterusan dalam kalangan kanak-kanak. Ia mampu mempengaruhi minda dan fikiran para pemain jika mereka terlalu taksab dan leka dengan permainan tersebut. Secara tidak langsung, hal ini telah memberikan impak yang negatif terhadap para pemain. Apabila diri mereka terbiasa dengan sikap leka dan taksab terhadap permainan video, mereka lebih cenderung untuk mengabaikan rutin harian mereka dan mengakibatkan keburukan terhadap diri mereka sendiri pada masa akan datang.

Bukan itu sahaja, malahan perkara ini juga memberi impak negatif terhadap kesihatan mereka. Sikap obses terhadap permainan video akan mengakibatkan mereka kurang mengambil berat terhadap kesihatan mereka dan cenderung untuk tidak mendapat tidur yang mencukupi. Justeru itu, keadaan otak mereka akan menjadi penat dan tidak dapat berfungsi dengan baik serta mengakibatkan kematian otak.

Kajian ini dijalankan adalah untuk mengkaji hubungan antara tahap ketagihan internet dengan pencapaian akademik murid sekolah rendah. Ini boleh merangkumi faktor seperti sokongan keluarga, corak penggunaan media sosial, pengaruh rakan sebaya, dan kesejahteraan emosi yang boleh mempengaruhi tahap ketagihan dan pencapaian akademik murid. Seterusnya, tujuan kajian ini dijalankan untuk menganalisis kesan ketagihan internet dengan pencapaian akademik murid sekolah rendah. Kajian ini melibatkan pengumpulan data tentang prestasi akademik, seperti keputusan ujian dan penilaian, serta membandingkan antara murid yang mengalami ketagihan internet dengan mereka yang tidak ketagih.

Objektif kajian ialah bagi mengenal pasti tahap ketagihan internet dalam kalangan murid sekolah rendah di Kuala Lumpur dan mengenal pasti hubungan antara ketagihan internet dengan pencapaian akademik dalam kalangan murid sekolah rendah. Selain daripada itu, objektif kajian ini juga bagi mengenal pasti kesan ketagihan internet dengan pencapaian akademik dalam kalangan murid sekolah rendah di Kuala Lumpur.

2. Ulasan karya

Dalam bahagian ini, tinjauan literatur mengenai kepentingan pencapaian akademik dalam kalangan murid sekolah rendah di Kuala Lumpur penyelidikan akan menerangkan impak dan kesan kepada ketagihan internet.

2.1 Kepentingan Pencapaian Akademik Di Sekolah Rendah

Kementerian Pendidikan Malaysia (KPM) berkeinginan untuk meningkatkan kualiti pengajaran dan pembelajaran di sekolah rendah. Ini termasuk pemilihan guru berkualiti, penggunaan kaedah pengajaran yang inovatif, dan penyediaan bahan pembelajaran yang berkualiti. Di samping itu, Kementerian Pendidikan Malaysia (KPM) berkeinginan untuk menyediakan persekitaran pembelajaran yang kondusif di sekolah rendah. Ini melibatkan aspek



seperti kebersihan dan keindahan persekitaran fizikal sekolah, fasiliti pembelajaran yang memadai, dan pengurusan yang efektif. Kementerian Pendidikan Malaysia (KPM) juga mendorong penglibatan ibu bapa dan komuniti masyarakat dalam menyokong proses pembelajaran murid di sekolah rendah.

2.2 Impak atau kesan ketagihan Internet Dalam Kalangan Murid Di Sekolah Rendah

Impak pertama yang mempengaruhi faktor Ketagihan internet sangat mempengaruhi kesihatan mental, menjadi isu utama dalam sains kesihatan mental. Seterusnya, impak kedua bagi faktor ketagihan internet pada murid sekolah rendah boleh menyebabkan masalah mental seperti depresi dan gangguan tidur. pada personaliti, serta menyebabkan keresahan dan kemurungan. Di samping itu, impak ketiga ketagihan penggunaan internet pada kehidupan sosial kanak-kanak adalah seperti isolasi sosial dan gangguan dalam hubungan interpersonal. Akhir sekali, impak keempat yang mempengaruhi ketagihan internet pada prestasi akademik menjelaskan impak negative ketagihan media sosial pada prestasi akademik, seperti penurunan konsentrasi dan kemampuan untuk menyelesaikan tugas seperti hilang fokus semasa belajar, tiada rasa minat semasa belajar bersama kawan-kawan, sentiasa berasa cepat bosan dan mengantuk.

2.3 Teori Berkaitan Dengan Ketagihan Internet

Kajian penyelidikan ini merujuk kepada Model Behavioural Model of Pathological Internet Use (PIU). Model PIU ini amat sesuai digunakan dalam bahan kajian penyelidik dimana model ini menceritakan tentang gejala ketagihan internet dan hubungan dengan pencapaian akademik pelajar. Menurut Davis (2000), ketagihan internet bersifat patologi secara amnya ditakrifkan sebagai ketagihan internet yang bermasalah dan kompulsif, yang mengakibatkan kemerosotan yang ketara dalam fungsi individu dan pelbagai domain kehidupan bagi tempoh masa yang berpanjangan.

Merujuk Model Davis (2000), pengkaji telah menggunakan Model PIU secara khusus dan umum. Model PIU khusus merujuk kepada orang yang hanya bergantung kepada penggunaan internet sahaja bagi orang yang kerap menggunakan internet untuk mengakses bahan seksual, perkhidmatan lelongan dan sebagainya yang merugikan pihak itu sendiri. Manakala Model PIU umum pula, menerangkan penggunaan internet yang berlebihan amnya dan multidimensi internet. Oleh hal yang demikian, maka penyelidik menggunakan teori Model PIU ini sebagai bahan rujukan dalam kajian penyelidikan.

2.4 Hubungan Ketagihan Internet Dengan Pencapaian Murid

Merujuk kajian oleh Awang Koding Che Tom & Zunaidah Tohalib (2018), yang melibatkan 274 pelajar di Universiti Malaysia Terengganu, meneliti hubungan antara ketagihan internet dan pencapaian akademik menunjukkan ketagihan internet dengan pencapaian murid di kalangan murid sekolah menengah lebih tinggi berbanding dengan ketagihan internet dalam kalangan murid di sekolah rendah. Manakala, menurut kajian (Jung et al. 2020), kajian yang dijalankan oleh penyelidik lebih berfokus kepada objektif permainan dalam talian bermasalah (POG) dan penggunaan Internet bermasalah Behavioural Model of Pathological Internet Use (PIU) telah menjadi masalah kesihatan mental awam yang serius, dengan gangguan permainan Internet. Walaupun kecenderungan imersif yang lebih tinggi diperhatikan pada orang yang terjejas oleh permainan dalam talian (POG), ianya memberi kesan serentak kecenderungan



imersif dan gangguan mental yang sangat berat dan, gangguan defisit perhatian serta hiperaktif (ADHD).

3. Kerangka Konseptual

Kerangka konseptual kajian ini dibentuk berdasarkan penggunaan dan ketagihan internet dijangkakan akan mempengaruhi pencapaian akademik pelajar. Sehubungan dengan itu, kerangka konseptual yang telah dibangunkan untuk kajian ini adalah berdasarkan Model Behavioural of Pathological Internet Use (PIU) oleh Davis (2000) boleh digambarkan seperti rajah berikut:

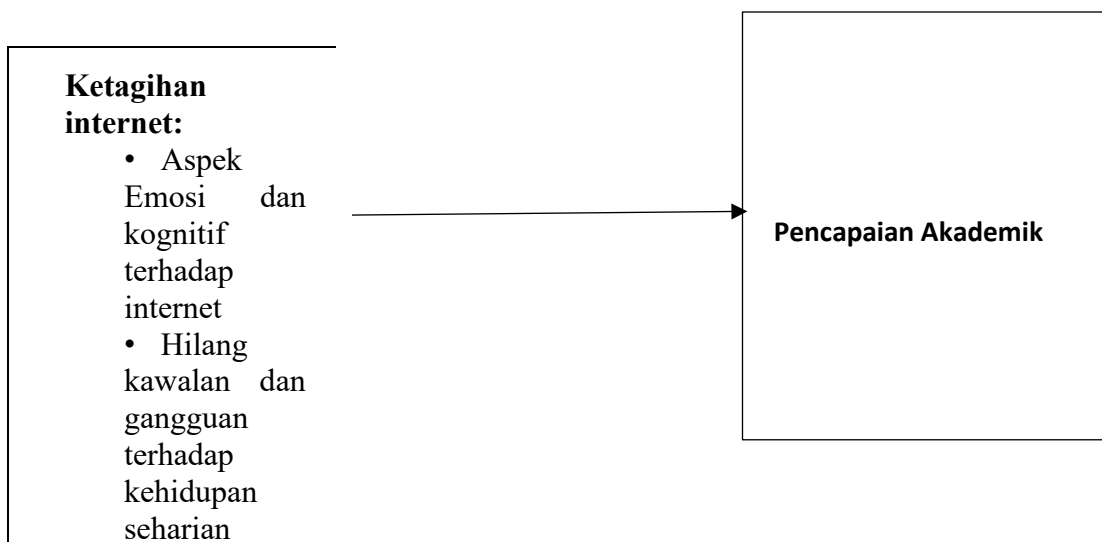

Rajah 1: kerangka konseptual kajian

4. Metodologi

Kajian ini akan menekankan pendekatan kuantitatif dengan menggunakan kaedah tinjauan yang berbentuk deskriptif. Oleh itu, instrumen untuk mendapatkan data dalam kajian ini adalah melalui penggunaan borang soal selidik. Bagi kajian ini, sampel kajian terdiri daripada 80 orang murid sekolah Rendah Kebangsaan Jalan Bellamy di Kuala Lumpur. Kajian ini menggunakan soal selidik sebagai instrumen kajian untuk mengumpul data yang diperlukan. Malahan, soal selidik ialah instrumen yang digunakan untuk mengumpul data yang memberikan penjelasan secara statistik, pada perhubungan dan analisis (Johnson & Christensen, 2002). Kajian ini akan menggunakan perisian SPSS versi 21 untuk menganalisis data. Analisis akan dilakukan berdasarkan soalan-soalan kajian dan melibatkan dua jenis statistik: deskriptif dan inferensi.

Dalam kajian ini pengkaji telah menggabungkan dua instrumen borang soal selidik yang terdiri daripada latar belakang responden dan tahap ketagihan internet dengan kesannya dan hubungan kedua angkubah tersebut terhadap pencapaian akademik murid dalam kalangan murid sekolah rendah di Kuala Lumpur. Dalam kajian ini, soal selidik terbahagi kepada dua bahagian iaitu Bahagian A dan Bahagian B. Bahagian A ialah maklumat latar belakang responden dan jenis aplikasi internet mengikut kekerapan yang dilayari oleh responden, dan Bahagian B adalah untuk mengukur tahap ketagihan internet.



Soal selidik ini adalah diadaptasi dengan sedikit modifikasi dari kajian Kimebrly Young (1989) dan Ab Majid, Yassin, Aziz & Zakaria (2021). Instrumen ini mengandungi 20 item yang mengukur sejauh mana ketagihan internet memberi kesan terhadap rutin harian, kehidupan sosial, produktiviti, pola tidur, emosi dan kebimbangan. Namun demikian, ketagihan internet diukur mengikut dua faktor iaitu Keasyikan Emosi dan Kognitif Dengan Internet dan Hilang Kawalan dan Gangguan Terhadap Kehidupan Seharian seperti yang diadaptasi dari kajian Abdul Majid et al (2021).

Pengkaji melakukan kajian rintis untuk menguji kebolehpercayaan dan keesahan instrumen yang akan digunakan. Kajian rintis ini penting untuk memastikan keabsahan dan kebolehpercayaan kajian sebenar. Pengujian nilai kebolehpercayaan dilakukan menggunakan perisian Statistical Package for the Social Science (SPSS) versi 15.0. Malah, menurut Hassan et al. (2012), nilai Pekali Alpha Cronbach antara 0.8 hingga 1.0 menunjukkan item dalam kajian adalah boleh diterima dan tidak perlu diganti. Nilai 0.8 dianggap cukup tinggi untuk menunjukkan kebolehpercayaan yang baik bagi suatu alat. Jika nilai kurang dari 0.8, pengkaji harus mengubah item tersebut dan melakukan kajian rintis lagi hingga mencapai nilai 0.8 atau lebih.

5. Dapatan Kajian

Dapatan kajian ini akan membincangkan dan menganalisis setiap objektif iaitu mengenal pasti tahap ketagihan internet dalam kalangan murid sekolah rendah di Kuala Lumpur, mengenal pasti hubungan antara ketagihan internet dengan pencapaian akademik dalam kalangan murid sekolah rendah dan mengenal pasti kesan ketagihan internet dengan pencapaian akademik dalam kalangan murid sekolah rendah di Kuala Lumpur.

5.1 Tahap Ketagihan Internet Dari Aspek Keasyikan Emosi Dan Kognitif Terhadap Internet

Berdasarkan pada sembilan item telah dianalisis untuk memperoleh maklumat dari aspek tahap ketagihan internet dari aspek keasyikan emosi dan kognitif terhadap internet dalam kalangan murid sekolah rendah di Kuala Lumpur. Terdapat lapan item yang menunjukkan tahap ketagihan internet dari aspek keasyikan emosi dan kognitif berada di tahap sederhana iaitu nilai min yang kurang daripada 1.66. namun sedemikian, item B7 “Berapa kerapkah anda tidak cukup tidur ketika melayari internet?” sahaja berada di tahap rendah iaitu nilai min sebanyak 1.63.

5.2 Tahap Dari Aspek Hilang Kawalan Dan Gangguan Terhadap Kehidupan Seharian

Berdasarkan pada analisis responden mengikut peratusan dan min berhubung dengan tujuan tertentu ketika melayari internet dari aspek hilang kawalan dan gangguan terhadap kehidupan seharian. Min tertinggi dalam jadual 4.7 ini adalah item ke-20 iaitu 2.89 yang berada pada tahap sederhana; “Berapa kerapkah anda cuba mengurangkan jumlah masa yang anda habiskan dalam talian tetapi gagal?”. Namun sedemikian, item ke-16, “Berapa kerapkah anda memeriksa media sosial sebelum melakukan tugas lain?” menunjukkan nilai min yang rendah sebanyak 1.63 dengan nilai sisihan piawai sebanyak 1.048. Hal ini dikatakan sedemikian kerana, sebahagian daripada responden kajian mengaku bahawa mereka tidak kerap memeriksa



media sosial sebelum melakukan tugas lain. Separuh daripada bilangan responden menggunakan Internet untuk melepaskan tekanan atau stress.

5.3 Rumusan Penerangan Mengenai Tahap Ketagihan Internet Dari Aspek Keasyikan Emosi Dan Kognitif Terhadap Internet Dengan Tahap Ketagihan Internet Dari Aspek Hilang Kawalan Dan Gangguan Terhadap Kehidupan Sehari-hari.

Bil	Item	Min	Tahap
1	Tahap ketagihan internet dari aspek keasyikan emosi dan kognitif terhadap internet	2.05	Sederhana
2	Tahap ketagihan internet dari aspek hilang kawalan dan gangguan terhadap kehidupan seharian	2.22	Sederhana

Sehubungan dengan itu, analisis dapatan kajian ini turut membuktikan bahawa nilai min untuk aspek keasyikan emosi dan kognitif terhadap internet ialah 2.05 manakala min tahap ketagihan internet dari aspek hilang kawalan dan gangguan terhadap kehidupan seharian adalah 2.22. Sesungguhnya, hal ini membuktikan bahawa tahap ketagihan internet dari aspek keasyikan emosi dan kognitif serta tahap ketagihan internet dari aspek hilang kawalan dan gangguan terhadap kehidupan seharian adalah sama sederhana dalam kalangan murid sekolah rendah di Kuala Lumpur.

5.4 Hasil Analisis Ujian Korelasi Pearson

		Pencapaian Akademik	Tahap Ketagihan
Pencapaian Akademik	Korelasi Pearson	1	0.182
	Sig. (2-ekor)		<.008
	N	80	80
Tahap Ketagihan	Korelasi Pearson	0.182**	1
	Sig. (2-ekor)	<.008	
	N	80	80

Hasil yang diperolehi mendapati bahawa terdapat korelasi yang positif di antara tahap ketagihan penggunaan internet dari aspek keasyikan emosi, kognitif, hilang kawalan dan gangguan kehidupan seharian dengan pencapaian akademik dalam kalangan murid sekolah rendah di Kuala Lumpur. Ini jelas daripada nilai Korelasi Pearson yang diperolehi adalah 0.182. Walaupun, pekali korelasi adalah rendah iaitu menghampiri nilai 0, namun masih terdapat korelasi positif di antara pencapaian akademik dengan tahap ketagihan internet dari aspek keasyikan emosi, kognitif, hilang kawalan dan gangguan kehidupan seharian dalam kalangan murid sekolah rendah di Kuala Lumpur.



6. Perbincangan

Sesungguhnya, dapatan kajian ini membuktikan bahawa murid-murid sekolah rendah yang terlibat dalam kajian ini menunjukkan bahawa tahap ketagihan melayari internet yang rendah dengan nilai min respons sampel sebanyak 2.05 dan 2.22 masing-masing. Oleh hal yang sedemikian, pengkaji turut berpendapat dan membuktikan bahawa penilaian tahap mengikut setiap item yang menerangkan ketagihan murid-murid sekolah rendah terhadap tahap ketagihan dari aspek keasyikan emosi dan kognitif serta tahap ketagihan dari aspek hilang kawalan dan gangguan kehidupan seharian untuk kebanyakan item seperti berasa takut jika tidak ada internet, malah menjadikan kehidupan ini menjadi bosan serta responden kajian turut berasa marah apabila diganggu semasa sedang melayari internet.

Sehubungan dengan itu, tahap ketagihan dari aspek keasyikan emosi dan kognitif yang menunjukkan sederhana adalah untuk item seperti murid lebih suka bermain internet daripada bermain dengan ahli keluarga serta murid turut menyatakan bahawa mereka mendapat kenalan baru di media sosial. Hal ini dikatakan sedemikian kerana murid-murid generasi sekarang lebih mengutamakan penggunaan media sosial seperti facebook, Instagram, Twitter, Snapchat, Whatsapp dan Tik Tok. Laman rangkaian sosial seperti ini, telah menjadi aplikasi popular di kalangan murid sekolah rendah. Sebilangan besar daripada mereka, terutamanya di Kuala Lumpur, melayari laman ini setiap hari, menandakan peningkatan penggunaan media sosial dalam kalangan generasi muda.

Perbandingan dengan kajian Rafidah (2010), menunjukkan peningkatan yang ketara hanya 18.4% murid yang melayari laman sosial setiap hari pada waktu itu. Ini menunjukkan pertumbuhan pesat dalam penggunaan media sosial dalam tempoh dekad yang singkat. Malahan, murid-murid pada era pemodenan kini mudah memiliki telefon bimbit dan mereka menggemari membuat akaun media sosial, seperti Facebook, dan menggunakannya melalui peranti mereka. Selanjutnya, kajian oleh Mohd Effendi (2010), menyokong penemuan ini dengan menunjukkan bahawa 54% pelajar mempunyai tahap ketagihan yang tinggi terhadap Facebook. Ini menunjukkan betapa mendalamnya pengaruh media sosial dalam kehidupan pelajar hari ini.

Hasil kajian ini sejajar dengan penemuan oleh Ahmad Johari dan Norbaizura (2010), yang menunjukkan bahawa kefasihan dalam menggunakan Internet secara tidak langsung meningkatkan kemahiran seseorang dalam e-pembelajaran. Kedua-dua kemahiran ini saling memperkuat, menunjukkan kaitan erat antara kemahiran internet dan pembelajaran digital. Sesungguhnya, 39.6% murid mengakui mereka sering mengakses bahan ilmiah dari Internet untuk tugas sekolah mereka. Ini menunjukkan kecenderungan pelajar menggunakan sumber online untuk mendukung kegiatan akademik mereka dan menegaskan lagi peranan penting Internet dalam proses pembelajaran.

7. Kesimpulan

Justeru itu, dapat disimpulkan bahawa masyarakat kini telah menyedari bahawa internet merupakan suatu keperluan peribadi untuk mendapatkan maklumat atau apa sahaja yang diinginkan hanya dengan sentuhan jari. Penggunaan internet di kafe siber mengalami penurunan seiring berlalunya masa, disebabkan kebanyakan individu di rumah sudah memiliki perkhidmatan internet sendiri. Dalam konteks ini, penyelidik mendapati bahawa penurunan ini berkait rapat dengan penurunan harga perkhidmatan Internet, membolehkan kebanyakan ibu



bapa mampu melanggan perkhidmatan internet setiap bulan. Selain itu, kebanyakan responden juga bersetuju memiliki minat dalam melayari internet sebagai hobi. Ini bermakna bahawa semasa waktu lapang, pelajar cenderung mengisi masa mereka dengan melayari internet. Oleh sebab minat yang mendalam ini, sesetengah pelajar mungkin mengalami ketagihan kerana mereka rela meluangkan masa untuk melayari internet demi keseronokan.

Oleh hal yang sedemikian, pemantauan dan penelitian lanjut mengenai isu ketagihan internet dalam pencapaian akademik perlu diambil kira untuk memastikan ke arah masa depan yang lebih cerah, hubungan sosial yang positif, dan kehidupan yang lebih teratur bagi murid-murid sekolah rendah. Ini adalah langkah penting dalam memastikan kesejahteraan murid dan memastikan mereka dapat mencapai potensi akademik yang cemerlang dan sosial mereka yang sejahtera secara holistik.

8. Rujukan

- Al Mawaddah, A. W., Hidayat, M. T., Amin, S. M. & Hartatik, S. 2021. Pengaruh Penggunaan Media Pembelajaran Quizizz terhadap Hasil Belajar Siswa pada Mata Pelajaran Matematika melalui Daring di Sekolah Dasar. *Jurnal Basicedu* 5(5): 3109–3116. doi:10.31004/basicedu.v5i5.1288
- Hassan, J., & Rashid, R. S. R. A. (2012). Ketagihan penggunaan internet di kalangan remaja sekolah tingkatan 4 di Bandaraya Johor Bahru. *Journal of Technical, Vocational and Engineering Education*, 6, 23-43
- Ahlgren, M (2023) Statistik, Fakta dan Trend internet 2023 di petik dari internet bertarikh June 2023 <https://www.websiterating.com/ms/research/internet-statistics-facts/>
- Asrese, K. & Muche, H. 2020. Online activities as risk factors for Problematic internet use among students in Bahir Dar University, North West Ethiopia: A hierarchical regression model. *PLoS ONE* 15(9 September). doi:10.1371/journal.pone.0238804
- Awang Koding Che Tom & Zunaidah Tohalib. 2018. Hubungan antara ketagihan internet dengan pencapaian akademik dalam kalangan pelajar Universiti Malaysia Terengganu (UMT). *Prosiding Konvensyen Keperolehan dan Felo Penghuni Kolej Kediaman Universiti Awam Kebangsaan*.
- Berita harian (2023) Rakyat Malaysia habiskan hampir tiga jam sehari guna media sosial. <https://www.bharian.com.my/bisnes/teknologi/2023/02/1062957/rakyat-malaysia-habiskanhampir-tiga-jam-sehari-guna-media-sosial>
- Castellacci, F., & Tveito, V. (2018). Internet use and well-being: A survey and a theoretical framework. *Research Policy*, 47(1), 308–325
- Danil, J. & Mohamed, S. 2021. Perubahan Tingkah Laku Kanak-kanak Disebabkan Penggunaan Gajet (Changes In Child behavior Due To Gadget Use). *Jurnal Dunia Pendidikan* 3(2): 200–209. Retrieved from https://www.farizakhalid.com/uploads/3/0/7/7/30779151/persoalan_kajian_.pdf
- Dzure, A. N. S., Jie, F. Y., Anuar, N. M. A. M. & Nurul Aliyah Mohd Nadzri, S. K. a/p M. S. F. 2021. Penglibatan Belia Dalam Isu Ketagihan Bahan 18(8): 166–178.
- Hassan, J., Shahrina, R. & Abdul, R. 2012. 11799898 6(June): 23–43.
- Hamzah, S. A. S., Nordin, N., & Mustafa, S. M. S. (2020). The Influence of Organizational Learning on Work Performance among Academic Staffs in Private Higher Learning Institutions. *International Journal of Academic Research in Business and Social Sciences*, 10(14), 224–237
- Joorabchi, T. N., Afshariyan, M. S. & Armat, R. 2022. Internet Addiction Mediates the Relationships Among Internet Skill and Gratification of Using Internet with Social



- Isolation Among Malaysian Youths: The Moderating Roles of Gender and Race. *International Journal of Education & Development using Information & Communication Technology* 18(2): 111–126. Retrieved from <https://ezproxy.unav.es/login?url=https://search.ebscohost.com/login.aspx?direct=true&AuthType=ip,cookie,uid&db=edo&AN=158838255&lang=es&site=edslive&scope=site>
- Jung, D., Shim, E. J., Park, H., Lee, K., Lee, S., Kim, E. Y., Chang, J. S., et al. 2020. The association between excessive internet gaming behavior and immersive tendency, mediated by attention deficit/hyperactivity disorder symptoms, in Korean Male University students. *Psychiatry Investigation* 17(5). doi:10.30773/pi.2019.0173
- Kurnada, N. & Iskandar, R. 2021. Analisis Tingkat Kecanduan Bermain Game Online terhadap Siswa Sekolah Dasar. *Jurnal Basicedu* 5(6): 5660–5670. doi:10.31004/basicedu.v5i6.1738
- Koca, T. T., & Berk, E. (2019). Influence of Internet addiction on academic, sportive, and recreative activities in adolescents. *Journal of Public Health*, 27, 531–536
- Kates, A., Wu, H., & Coryn, C. (2018). The effects of mobile phone use on academic performance: A meta-analysis. *Computers & Education*, 127, 107–11
- Latubessy, A. & Wijayanti, E. 2017. Model Identifikasi Kecanduan Game Menggunakan Backward Chaining. *Simetris: Jurnal Teknik Mesin, Elektro dan Ilmu Komputer* 8(1): 9–14. doi:10.24176/simet.v8i1.807
- Nurathirah Abd Nasir. 2019. Pengaruh Elemen Gamifikasi Digital Terhadap Motivasi Pelajar Menggunakan Aplikasi Quizizz 1–83.
- Rickless Das, Ferlis Bin Bullare @ Hj. Bahari & Habibie Ibrahim (2014). Penggunaan Internet Dan Kesannya Terhadap Kesejahteraan Subjektif Dalam Kalangan Remaja: Perbandingan Peranan Tanggungjawab Jenis-Jenis Gaya Keibubapaan. *Fakulti Psikologi Dan Pendidikan. Universiti Malaysia Sabah.*
- Sengupta, A., Broyles, I., Brako, L., & Raskin, G. (2018). Internet addiction: Impact on academic performance of premedical post-baccalaureate students. *Medical Science Educator*, 28, 23–26
- Wan Hamzari, Ahmad Fauzi Mohd Ayub & Mokhtar Nawawi (2011). Masalah Ketagihan Internet Dalam Kalangan Pelajar Aliran Sains dari Perspektif Gender. *Malaysia Citation Centre*, 34, 25-36
- Zhang, Y., Qin, X., & Ren, P. (2018). Adolescents' academic engagement mediates the association between Internet addiction and academic achievement: The moderating effect of classroom achievement norm. *Computers in Human Behavior*, 89, 299–307