



HALAL IN THAILAND: CHALLENGE & OPPORTUNITY

Dr. Winai Dahlan

D.Sc.(magna cum laude) ULB, Assoc.Prof.

The Founding Director

The Halal Science Center, Chulalongkorn University

Chairman, Muhammadiyah Foundation

Honors:

- King's service medal of 'Dushdi Mala' in science 2009
- 1 of 'The World's 500 Most Influential Muslims' in Sci/Tech for 15 consecutive years (2010-2024), the Royal Islamic Strategic Studies Centre (RISSC), Jordan.
- International Halal Science Awards: Sarajevo 2023, London 2017, Manila 2009, KL 2006



“International Conference on Contemporary Halal and Fatwa [ICCoHaF] 2024”
September 18, 2024, Raja Brooke Ballroom, Nilai Spring Resort Hotel, Negeri Sembilan, Malaysia



Global Halal Economy: Opportunity of Thailand

GLOBAL AGRI-FOOD ECONOMY

17% of global agri-food is considered as 'Halal' for Muslims (24% of the world population)

72% contains neither pork nor alcohol which has potential to be uplifted as Mubah/Halal for non-Muslims.

11% contains pork and alcohol and is considered as Haram or Non-Mubah/Halal for non-Muslims.

Tapped Potential in 2023 (5.331 Trillion/year or 1.694 excl. IF)

- Fd & Agri (\$1,501 billion/year, +14.5%/yr) [88.6% excl Islamic Finance]
- Cosmetics (\$37.38 billion/year, +15%/yr) [2.2% exc IF]
- Islamic Fashion (\$50.52 billion/year, +5.7%/yr) [2.98% exc IF]
- Media & Entertainment (\$0.231 billion/year, +7.5%/yr) [0.01% ex IF]
- Pharma & Medicine (\$0.457 billion/year, +29%/yr) [0.02% ex IF]
- Travel/Tourism (\$105 billion USD/year, +16.5%/yr) [6.20% exc IF]
- Islamic finance (IF) (3,637 billion USD/year, +7.9%/yr) [68% of Halal E]

Untapped Potential in 2023

- **Intangible:** Invaluable price of Halal is hidden as brands/signs/culture/soft power in both societies of Muslims and non-Muslims.
- **Tangible:** 89% of global food is non-pork/non-alcoholic products, 16.6% of this segment is Halal for Muslims, the remaining 72.4% has potential to be uplifted as Mubah/Halal for non-Muslims. The latter, however, occasionally revealed some **complicated Haram contamination.**

(Multi sources in Google.com Aug 26, 2023, HSC.CU 2024)



Complicated Haram Contamination: Challenge for Fatwa

Cases of Porcine contaminated INS-631 found in Indonesia (2001) and Pakistan (2009)

www.drwinai.com

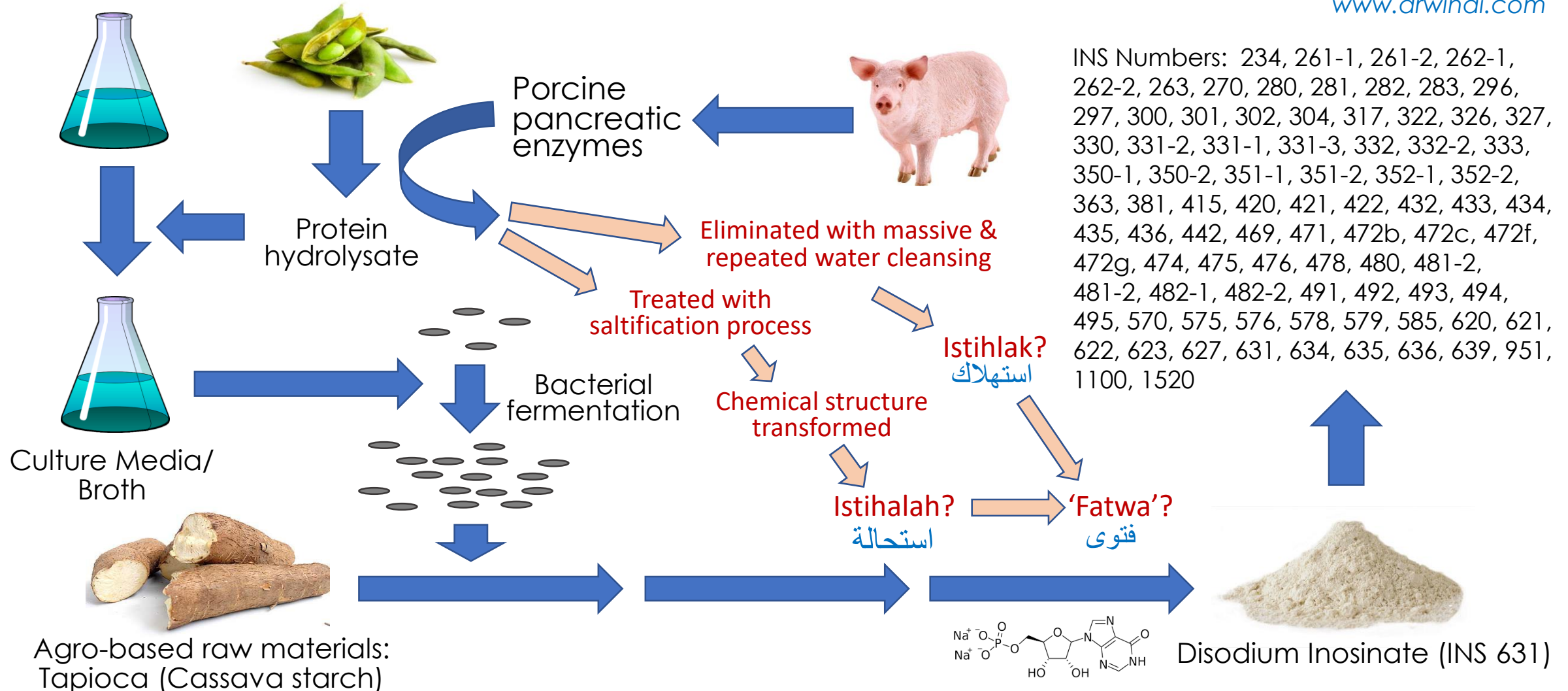

Complicated Haram Contamination: Challenge for Fatwa

Case of COVID-19 Vaccines as Rumor Spreaded in ASEAN Muslim Region [2021 & 2022]

www.drwinai.com

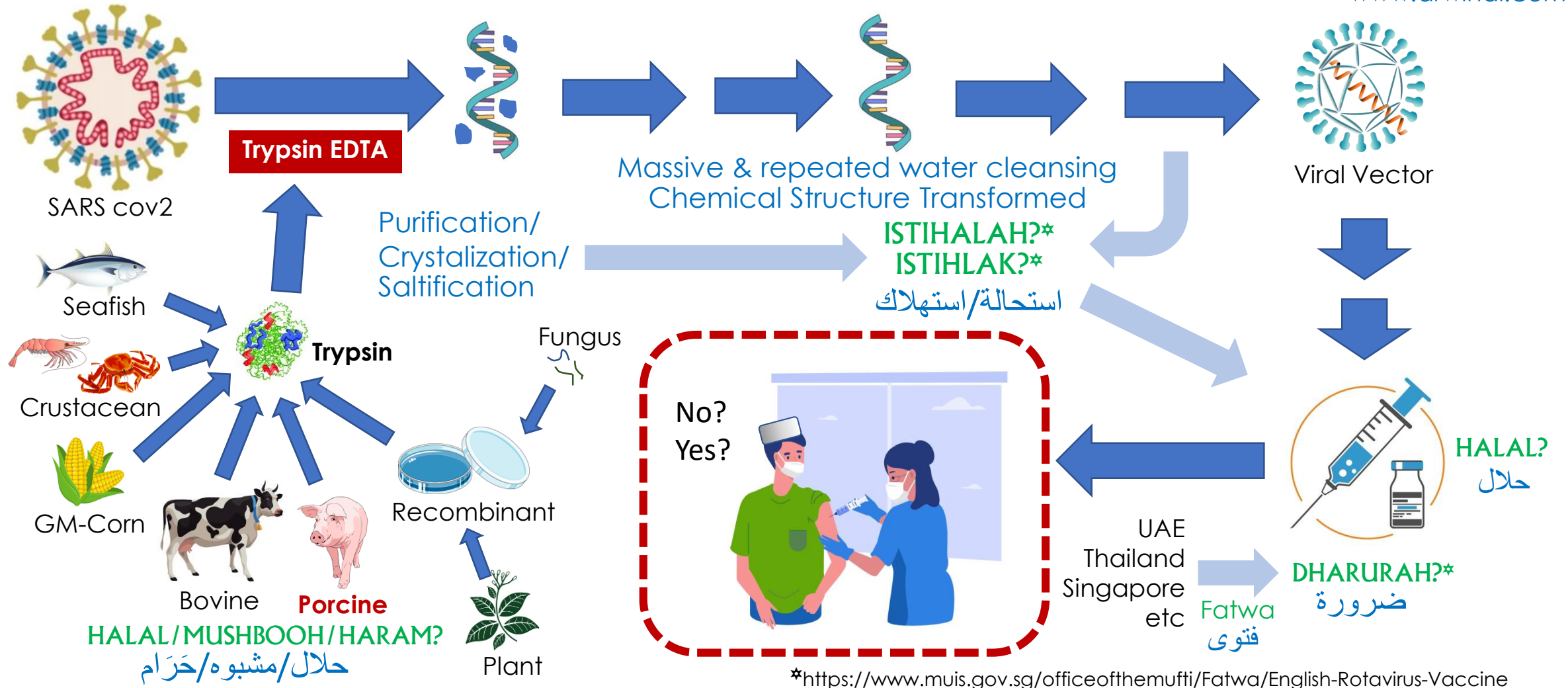

Al Quran's Guidance of 'How To' Find The Knower [Az Zikri]



وَنَيْسِرُكَ لِلْيَسْرَىٰ

(Al A'la 87:8) We will facilitate for you the Way of Ease.



يَا أَيُّهَا النَّاسُ كُلُوا مِمَّا فِي الْأَرْضِ حَلَالًا طَيِّبًا وَلَا تَتَّبِعُوا خُطُوَاتِ الشَّيْطَانِ إِنَّهُ لَكُمْ عَدُوٌّ مُّبِينٌ ﴿١٦٨﴾

1 **What to eat?** – “People, eat what is Halal and Tayyib from the earth, and do not follow Satan's footsteps, for he is your sworn enemy” [Al Baqara 2:168].

وَلَا تَقُولُوا لِمَا تَصِفُ أَلْسِنَتُكُمُ الْكَذِبَ هَذَا حَلَلٌ وَهَذَا حَرَامٌ لِّتَفْتَرُوا عَلَى اللَّهِ الْكَذِبَ إِنَّ الَّذِينَ يَفْتَرُونَ عَلَى اللَّهِ الْكَذِبَ لَا يُفْلِحُونَ ﴿١١٦﴾

2 **How to judge?** – “Do not say lie, ‘This is Halal and that is Haram,’ inventing a lie about Allah: those who invent lies about Allah will not prosper-” [An Nahl 16:116]

وَمَا أَرْسَلْنَا قَبْلَكَ إِلَّا رِجَالًا نُّوحِي إِلَيْهِمْ فَسْأَلُوا أَهْلَ الذِّكْرِ إِنْ كُنْتُمْ لَا تَعْلَمُونَ ﴿٧﴾

3 **Whom to ask?** - And even before your time [Muhammad], all the messengers We sent were only men We inspired, if you do not know, ask people who know (Az Zikri). [Al Anbya 21:7] (Az Zikri → Shariah scholar who has Halal scientist's advice)

وَإِذْ قَالَ مُوسَىٰ لِفَتَاهُ لَا أَبْرَحُ حَتَّىٰ أَبْلُغَ مَجْمَعَ الْبَحْرَيْنِ أَوْ أَمْضِيَ حُقُبًا ﴿٦٠﴾

4 **Where to find?** - Moses said to his servant (Yusa ibn Noon), 'I will not rest until I reach the place where the two seas meet (Majma al Bahrain), even if it takes me years!' [Al Kahf 18:60] (Majma al Bahrain → Shariah scholar & scientist with ample Halal science & Shariah literacy & advice).



AI Quran's Guidance of 'How To' Create The Knower [Az Zikri]

www.drwinai.com

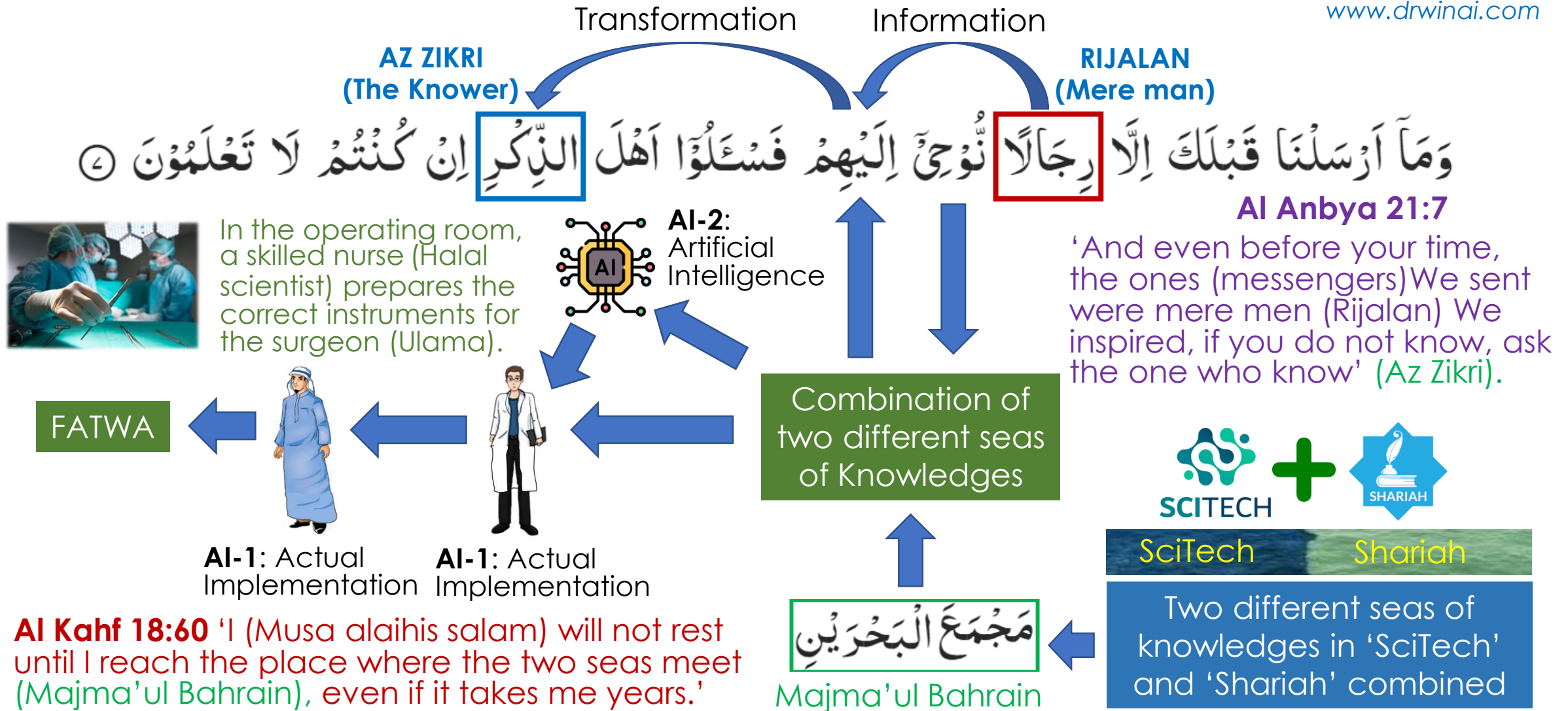

Strategy for Solving Complicated Haram Adulteration in Halal Industry & for Uplifting Country's Competitiveness in Global Halal Market

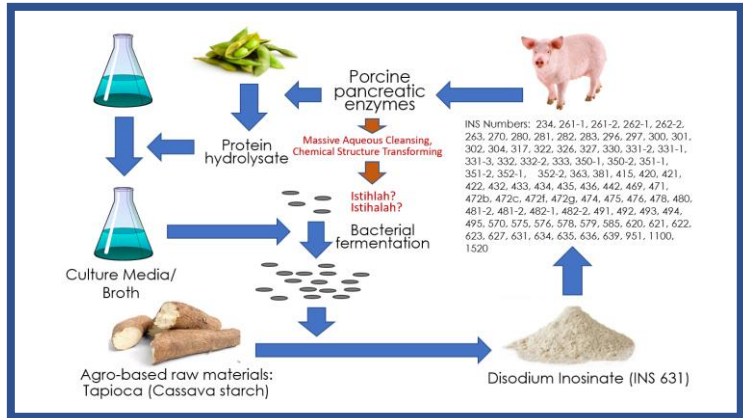

INS 631 Scandal In 2001



1949
Initiation of Halal Certification by Office of Shaik al Islam



1997-99
Islamic Organization Administration Act & Thailand Halal Food Standard



Sep 24, 2003
Establishment of The Halal Standard Institute of Thailand

Started Halal certification by the Islamic organizations

Develop the Halal certification infrastructure and prepare for Halal standards.

Restructuring Halal certification in Thailand by law

THAI CABINET RESOLUTIONS UPON HSC.CU

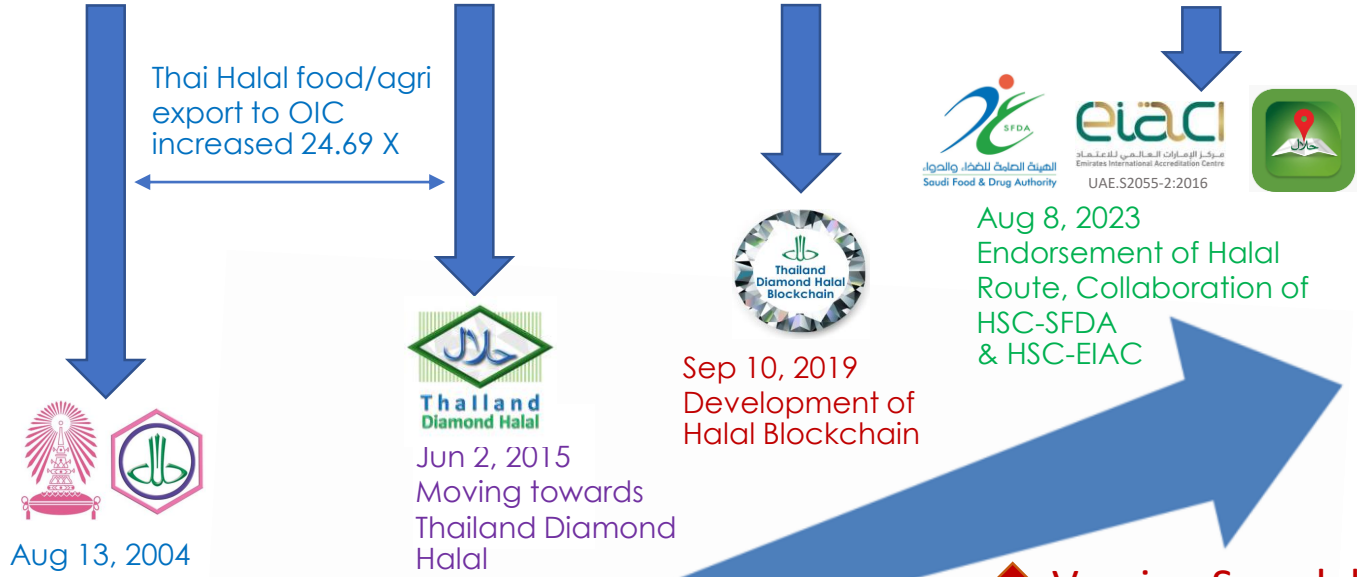

Thai Halal food/agri export to OIC increased 24.69 X



Aug 13, 2004
Upliftment of The Halal Science Center, Chulalongkorn University [HSC.CU]



Jun 2, 2015
Moving towards Thailand Diamond Halal

Sep 10, 2019
Development of Halal Blockchain



Aug 8, 2023
Endorsement of Halal Route, Collaboration of HSC-SFDA & HSC-EIAC

Vaccine Scandal In 2020-21

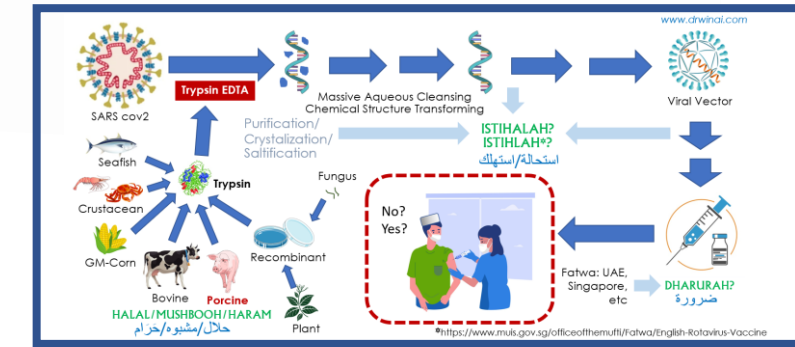

THAILAND'S INFRASTRUCTURE OF HALAL CERTIFICATION

According to Islamic Organization Administration Act 1997 and CICOT Regulation on Halal Affair 2015



Group of HABs Group of HABs



CICOT

HCB

CICOT's Department of Halal

Islamic Committee of Provinces

HCB

- HSC's Scientific Supports:
- Forensic Sci Lab screening
 - HAL-Q Halal Standardization
 - H numbers Halal raw material data support
 - Training of Halal inspectors/Halal advisors/Halal SMEs/Entrepreneurs
 - Platform development: Halal blockchain/Halal route/IT facilities
 - Etc



HSIT

Cabinet resolution
Sep 24, 2002



Academic support



TRAINING CENTER

Cabinet resolution
Sep 10, 2019

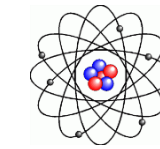
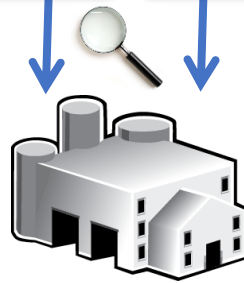

Scientific support

Cabinet resolution
Jun 2, 2015



HSC
Cabinet resolution
Aug 13, 2003



Religion Certifies - Halal Science Supports
Thailand Diamond Halal

The Halal Science Center (HSC) Chulalongkorn University

Est. 2004 (Cabinet resolution on Aug 13, 2003, CU Council resolution on Dec 23, 2004)



HABIDAH
The Halal Big Data House



Chiangmai branch
est. 2012
area 576 sqm.

Develop and support Halal science activities in North/North Eastern Regions. Develop and operate digital technology and precision agriculture. Work in collaboration with BIMSTEC/GMS.

HAFOLAB
Halal Forensic Laboratory



BIHAP

The Business Incubator of Halal Products

Bangkok Head Office
est. 2004
area 2,742 sqm.

SMIIC
THE STANDARD AND METROLOGY INSTITUTE FOR ISLAMIC COUNTRIES

Coordination Center

Develop and support Halal science activities in Central/Eastern Regions. Develop and operate Halal forensic laboratory and Business Incubator of Halal Products. Work in collaboration with SMIIC & national/international agencies.

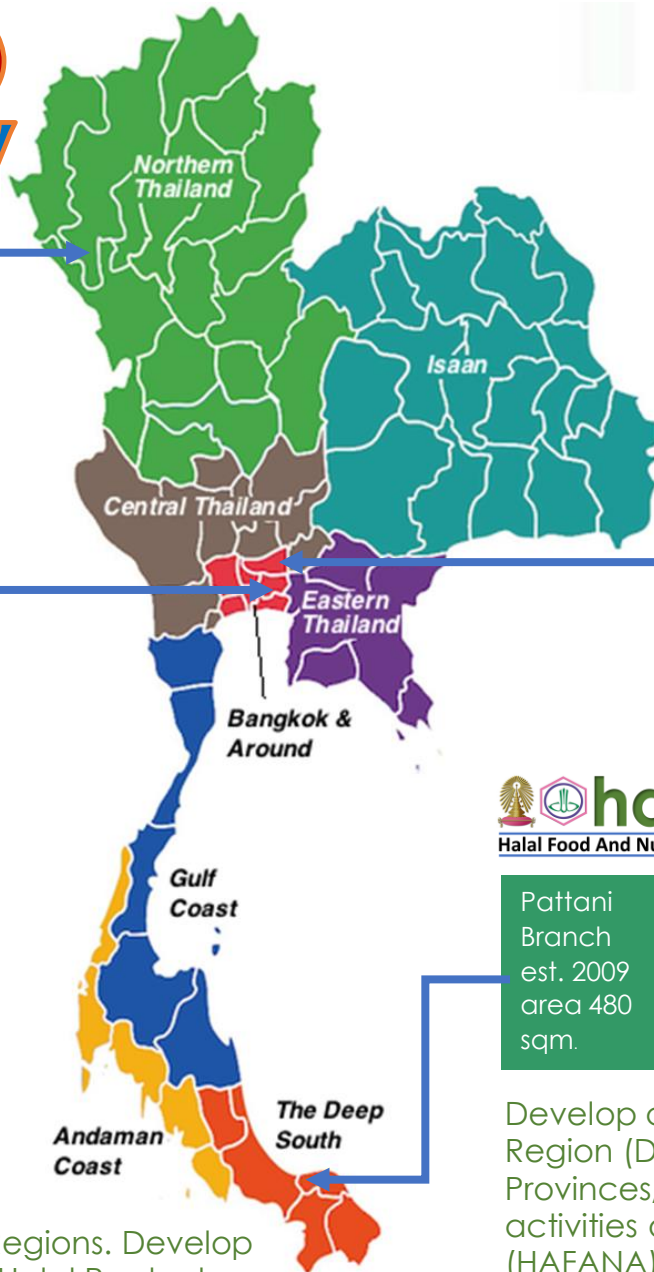

HICOLEC

The Halal Innovation Community Learning Center & Thinking school

Nakhon Nayok Community Office & Thinking school
est. 2022
area 2.8 acres.



Develop and support Halal science activities in area. Develop and operate precision agriculture. Administer and operate activities of the Halal Innovation Community Learning Center (HICOLEC) & Thinking school.

hafana
Halal Food And Nutrition Awareness

The Halal Food and Nutrition Awareness

Pattani Branch
est. 2009
area 480 sqm.



Coordination Center

IMT-GT
INDONESIA-MALAYSIA-THAILAND GROWTH TRIANGLE

Develop and support Halal science activities in Southern Region (Deep Southern Provinces/West Gulf of Thailand Provinces/Andaman Provinces). Administer and operate activities of the Halal Food and Nutrition Awareness (HAFANA). Work in collaboration with IMT-GT/ BIMP-EAGA



Halal Products Infrastructure: Halal Supply Chain

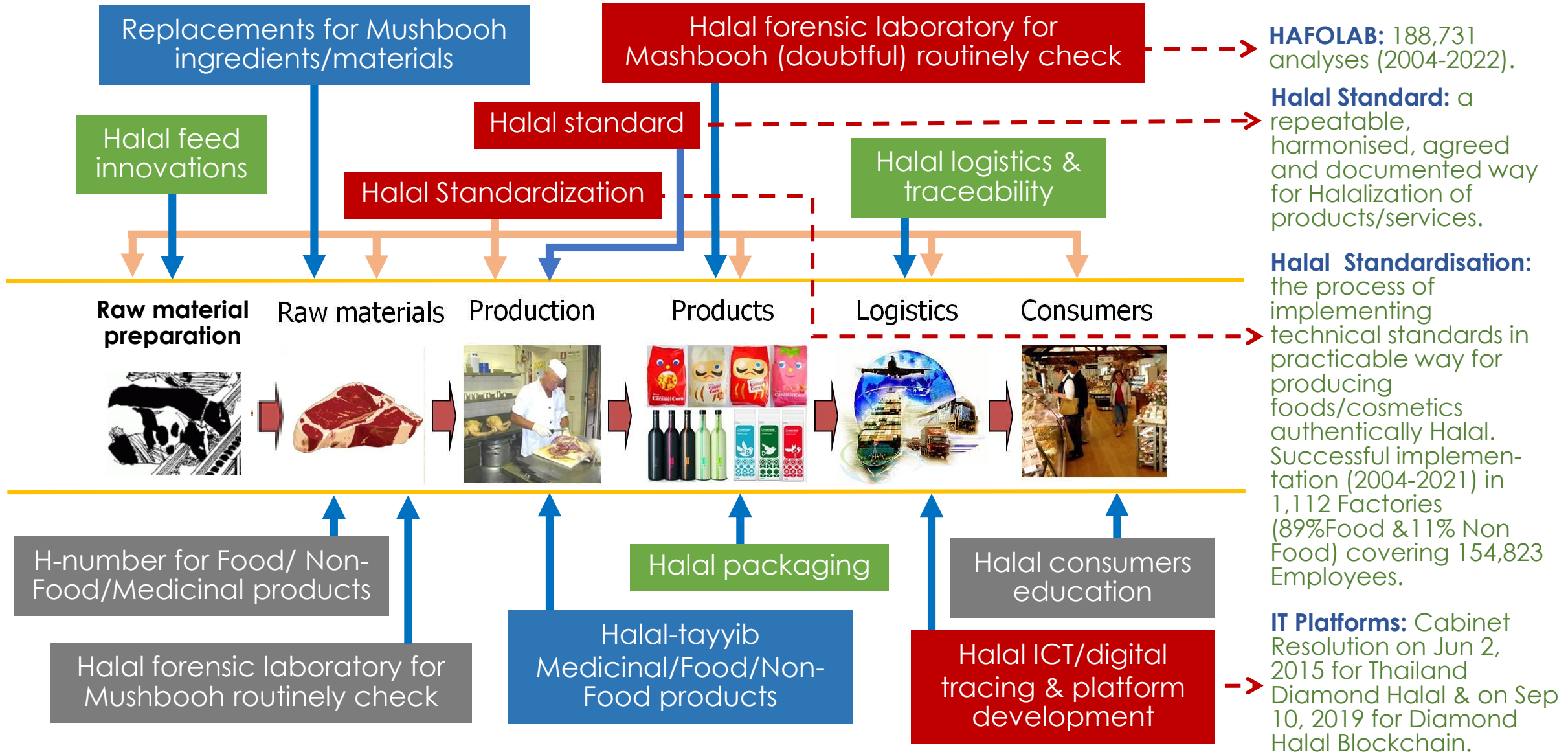

Algorithmic Design of HSC's Halal Science Application for Thailand's Halal Integrity

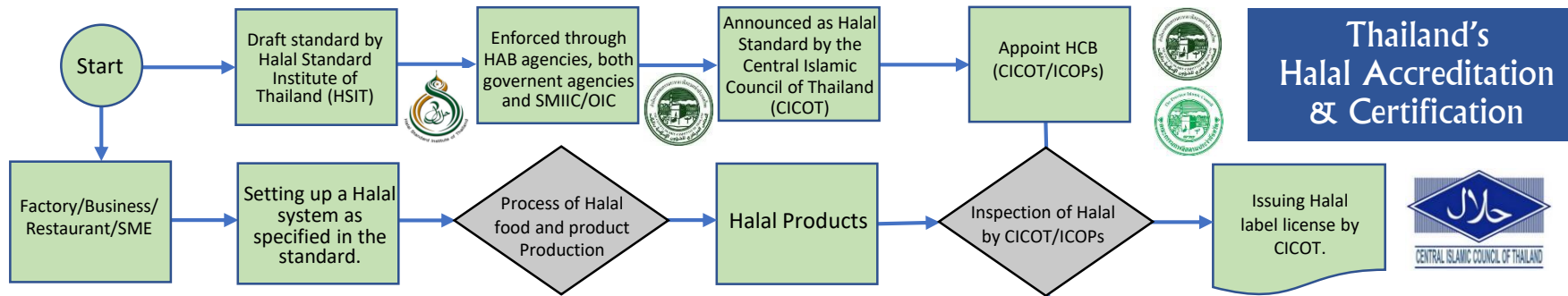

HAL-Q was preliminary developed as Halal-GMP/HACCP system in 2000 and received HJ award from Malaysian PM in 2006 and 2 Thai Government's Supreme Awards in 2013 for HAL-Q and in 2019 for H numbers.

Halal SciTech Application [1-4]

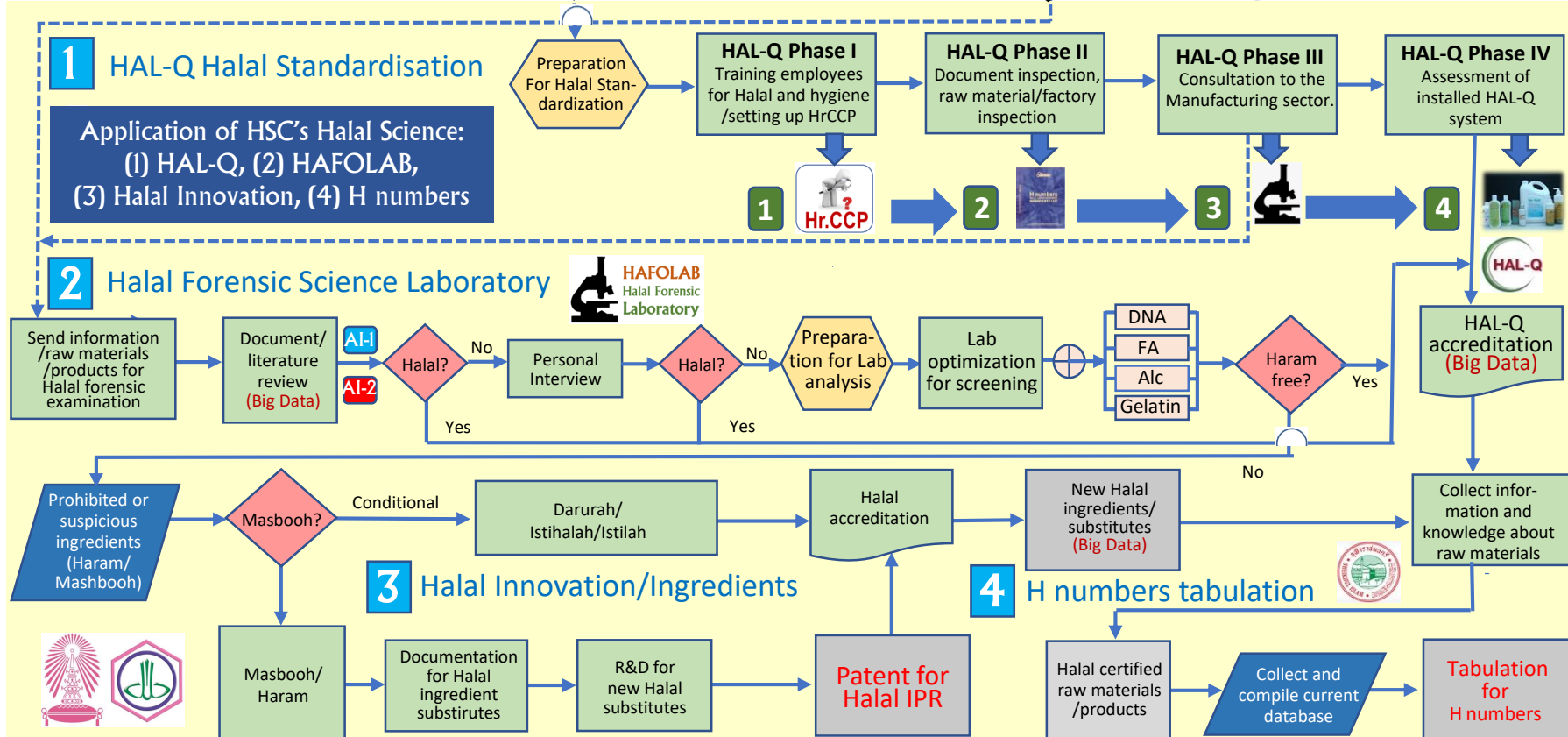

HAL-Q Halal Standardisation [2004-2022 AD] implemented in **1,112 factories**: 89% food, 11% non-food covering **158,823 workers**. Halal Forensic Science Lab performance [2004-2022 AD] analyzed **188,731 samples**, data used for tabulation of H numbers.

2 AI Systems [2 THAI's] are introduced into the process: **AI-1, Actual Implementation** by human (Rijalan) for processing HAL-Q, Lab analyses & Fatwa (Shariah judgement). **AI-2, Artificial Intelligence** by machines for processing Big Data, deep information etc.



Halal Forensic Science Laboratory Services

Laboratory has 2,000 sqm of area, >200 pieces of scientific equipment, 35 personnels including 8 PhDs: 7 in SciTech and 1 in Shariah. In-house biochemical techniques for Haram analyses are Gelatin, Protein profiles, Fatty acid profiles, DNA & DNA base sequences, Ethyl alcohol & Polar content. All lab services are accredited by **ISO/IEC 17025 : 2017** and lab management by **ISO 9001 : 2008**.



GELATIN/COLLAGEN ANALYSES BY LC-MS/ESI

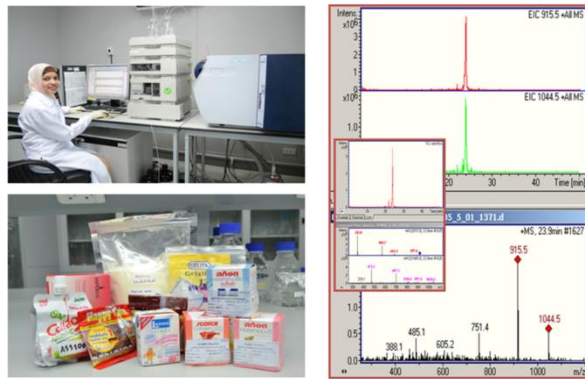

LIPIDS

eg. lard, glycerin, FAs, PLs

- FTIR-ATR (Syahariza et al 2005)
- Sensing Electronic Nose (Jia et al 2011)
- GC-TOF/MS (Witjaksono et al 2017)
- GC-MS/MS, GC-FID (HSC 2018, Lepage and Roy 1984, 1986)
- DSC (Marikkar et al 2001)

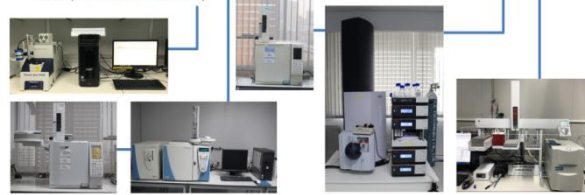

ETHYL ALCOHOL BY GC-FID

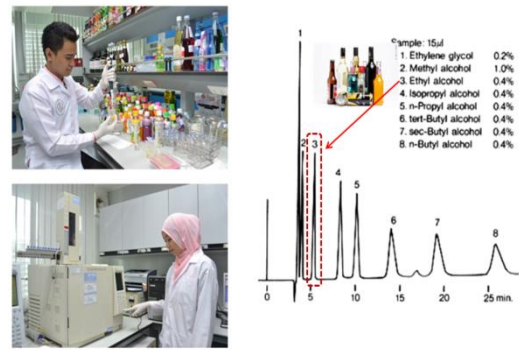

DNA

Appropriate extraction of DNA is highly essential

- PGM (HSC In house method 2018)
- Nanodrop (HSC In house method 2018)
- Droplet digital-PCR (HSC In house method 2018, Nikzad et al 2017)
- Real time-PCR (HSC In house method 2018)
- PCR-RFLP (Sultana et al 2018, Raharjo et al 2012)



PROTEINS

eg. gelatin, enzymes, hormones

- FTIR-ATR/PCA (Irfanita et al 2017)
- Colorimetry (HSC 2018, AOAC 990.26)
- LC-ESI/MS, LC-TQ/MS, LC-TOF/MS (HSC, In house)



Development of Simultaneous Multiplex DNA Analyses of 9 Animal Species for Tracing Haram Adulteration

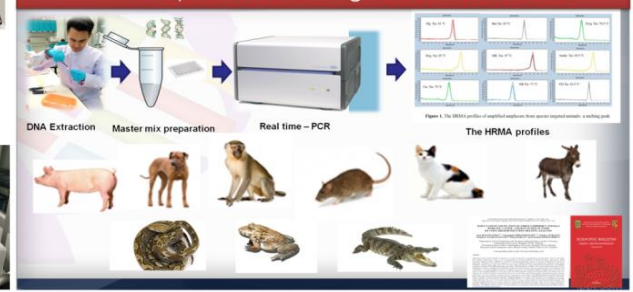



Development of Halal H numbers

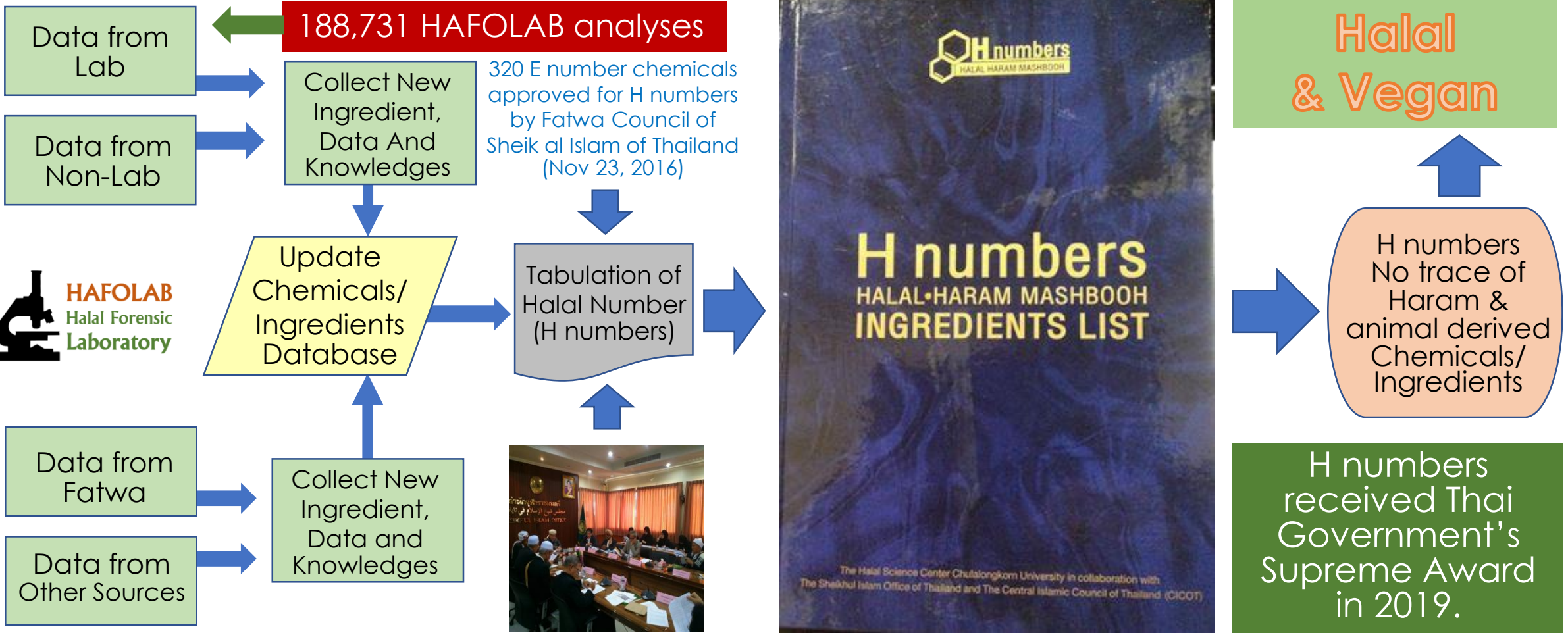

HACCP-based 'HAL-Q' for Halal Products Preparation

HACCP-based 'HAL-Q' (Halal Assurance, Liability-Quality System), are divided into 4 phases: (1) Classroom training (2) Document and production site inspection (3) Production site consultation with 4 combined processes : a) Setting up Haram Critical Control Points (Hr.CCP); b) Application of H numbers database; c) Halal forensic laboratory analyses; d) Cleansing of Najis and Haram and (4) Evaluation. HAL-Q are honored by: 2006 Malaysian PM's Award, 2013 & 2019 Thailand Government's Premier Awards.

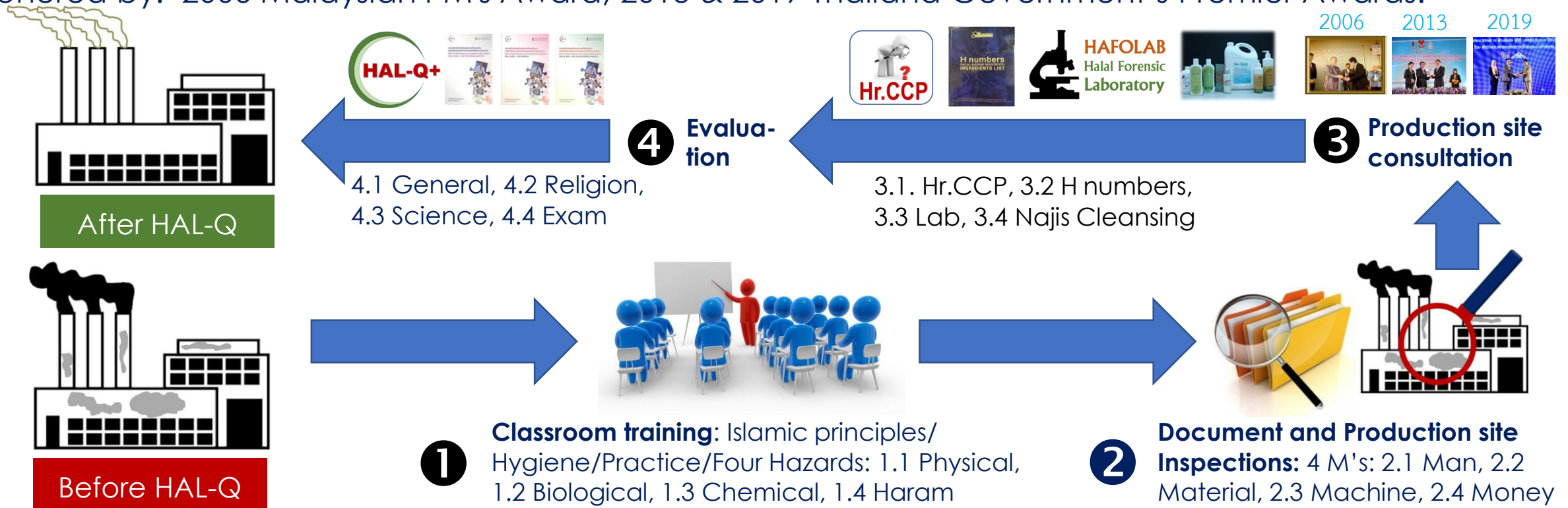

2024: THAI's [Thailand Halal Trustworthy AI's] for Halal Blockchain Development

Halal SciTech Application [1-5]

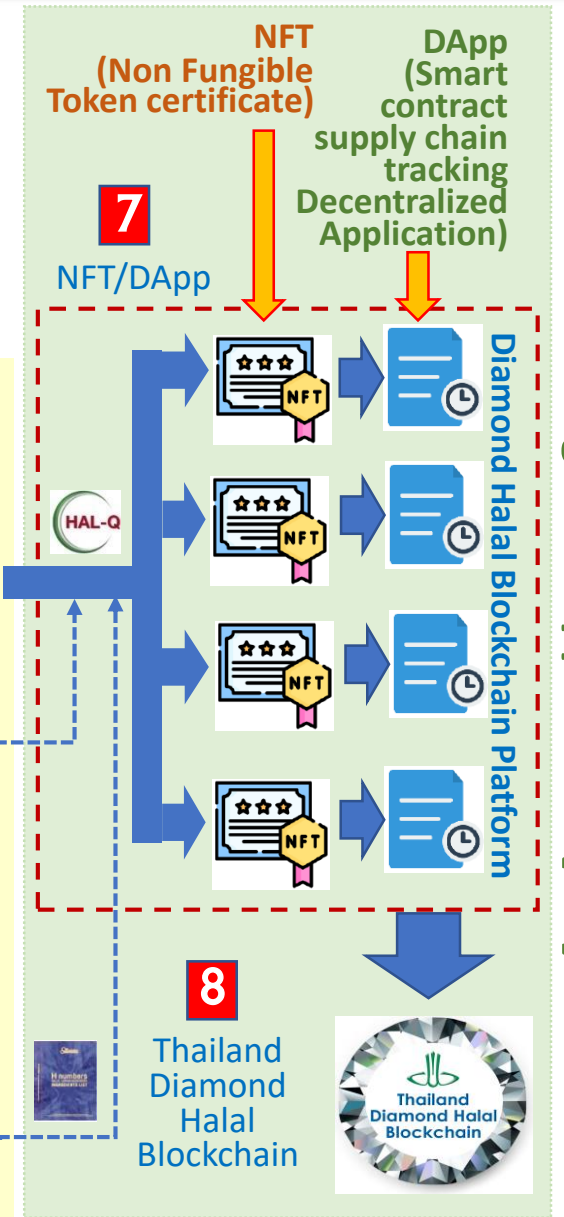
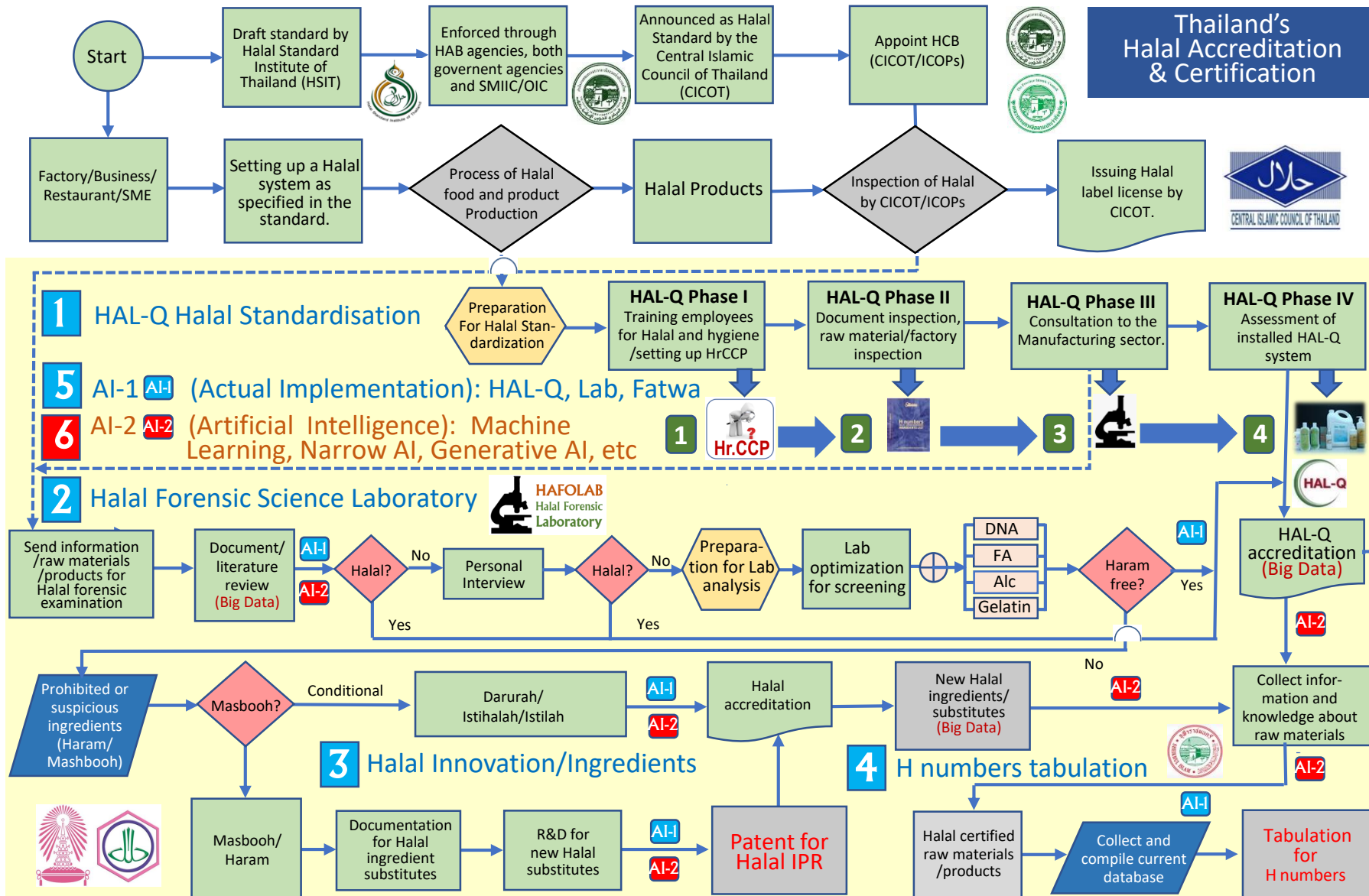

Halal DigiTech Application [6-8]



ขอบพระคุณทุกท่าน

شكرا لكم جميعا
با تشكر از همه شما

Thank you
Merci à tous
Terima kasih

